



**Ecosystem Accounting in Armenia:
Setting the Scene**



Leibniz Institute of
Ecological Urban and
Regional Development

Prototype Ecosystem Accounting of Armenia (Terrestrial Ecosystems)

Version 1

Technical Report

Yerevan
2026



Ecosystem Accounting in Armenia: Setting the Scene



Leibniz Institute of
Ecological Urban and
Regional Development

The project is being implemented by the Biodiversity Conservation Center (BCC Armenia), in collaboration with the Leibniz Institute of Ecological Urban and Regional Development (IOER, Germany), with the participation of experts from leading scientific organizations in Armenia.



Federal Ministry
for the Environment, Nature Conservation,
Nuclear Safety and Consumer Protection



Federal Agency for
Nature Conservation



This project is funded by the German Federal Environment Ministry's Advisory Assistance Program (AAP) for environmental protection in the countries of Central and Eastern Europe, the Caucasus and Central Asia and other countries neighboring the European Union. It is supervised by the Federal Agency for Nature Conservation (BfN) and the German Environment Agency (UBA).

The responsibility for the content of this publication lies with the authors

Project experts from Armenian side:

Aleksanyan Alla (Institute of Botany after A. Takhtajyan NAS RA)
Asatryan Vardan (Scientific center of zoology and hydroecology, RA)
Bayburdyan Ani (Freelancer)
Davtyan Ashot (Trails for Change NGO)
Fayvush George (Institute of Botany after A. Takhtajyan NAS RA)
Ghrejyan Tigran (Scientific center of zoology and hydroecology, RA)
Khitaryan Liana (Trails for Change NGO)

Project volunteers:

Arshakyan Armine;
Baghdasaryan Kristina

Project experts from German side:

Grunewald Karsten (Leibniz Institute of Ecological Urban and Regional Development (IOER))
Syrbe Ralf-Uwe (Leibniz Institute of Ecological Urban and Regional Development (IOER))

Project experts from NextGIS OÜ, Estonia:

Kazakov Eduard,
Dubinin Maxim

Project partners:

Leibniz Institute of Ecological Urban and Regional Development (IOER), Germany
NextGIS OÜ, Estonia

Project coordinator – *Armen Grigoryan* (BCC Armenia)

Project scientific supervisor – *Elena Bukvareva* (BCC Armenia)

Recommended citation: BCC Armenia. (2026). *Prototype ecosystem accounting of Armenia (terrestrial ecosystems):*

Version 1 – Technical Report (Bukvareva, E., Ed.; Aleksanyan, A., Arshakyan, A., Asatryan, V., Bayburdyan, A., Bukvareva, E., Davtyan, A., Dubinin, M., Fayvush, G., Ghrejyan, T., Grigoryan, A., Kazakov, E., Khitaryan, L., Syrbe, R. U., & Grunewald, K.).

Text, data and maps: © BCC Armenia

Cover photo: Partly cultivated Armenian mountain steppe landscape (© K. Grunewald)

Contents

Summary	6
1. Introduction: the aim and general methodology of the project	9
1.1. Aim of the project	9
1.2. System of Environmental-Economic Accounting—Ecosystem Accounting (SEEA EA).....	9
1.3. Ecosystem accounting in Armenia	10
1.4. Ecosystem Accounting Prototype Version 1: content and methodology	10
2. Ecosystem extent	16
2.1. Testing available land cover datasets and dataset selection for PV1	16
2.1.A. Area of land cover classes in the tested datasets.....	17
Share of land cover classes in Armenia.....	17
Share of land cover classes across marzes.....	17
Share of land cover classes across landscape zones.....	21
2.1.B. Comparison of cropland area according to land cover datasets and Armstat data.....	23
2.1.C. Selection of land cover dataset for use in the project.....	25
2.2. Extent of land cover classes	26
2.2.A. Extent of land cover classes reported by the Government of Armenia	26
2.2.B. Extent of land cover classes by Esri data.....	27
Extent of land cover classes at the national, marz, and watershed levels	28
Changes in land cover class extent	30
2.3. Extent of ecosystems (vegetation types)	34
2.3.A. Ecosystem extent at national and marz levels.....	34
2.3.B. Ecosystem rarity in Armenia	36
2.3.C. Changes in ecosystem extent from 2017 to 2023	37
2.3.D. Reduction of the potential area of vegetation types identified on the 1961 vegetation map	41
2.4. Extent of natural landscapes.....	44
2.4.A. Extent of natural landscapes in Armenia	44
2.4.B. Changes in extent of natural landscapes from 2017 to 2023 based on Esri data	47
2.4.C. Natural landscape extent at marz level.....	47
2.4.D. Assessment of marz importance for conservation of natural landscape diversity in Armenia	50
2.5. Ecosystem extent estimated by landscape-land cover classes (LLCCs)	52
2.5.A. Extent and rarity of LLCC in Armenia	52
2.5.B. Marz level: LLCC extent and marz importance for conservation of LLCC diversity in Armenia	54
2.5.C. Changes in LLCC extent and in marz importance for the conservation of LLCC diversity in Armenia	57
2.6. Ecosystem extent in protected areas	59
2.6.A. Extent of protected areas in Armenia	59
2.6.B. Ecosystem extent in PAs based on Esri land cover data.....	60
2.6.C. Changes in the areas of land cover classes in state reserves and national parks	65
2.6.D. Distance from natural monuments to anthropogenic areas and roads	65
2.7. Approaches to integrating Armenia into the Global Ecosystem Atlas	68
2.7.A. Zero version of Armenian ecosystem map for the GEA	68
2.7.B. Ecosystem extent according IUCN Global Ecosystem Typology.....	71
2.7.C. Comparison of Zero version maps for the GEA with government-reported data.....	73
2.7.D. Subsequent versions of the map.....	74
2.8. Examples of EE accounting tables	75
Extent of land cover classes by Government-reported data (Section 2.2.A).....	75
Extent of land cover classes by Esri land cover data (Section 2.2.B).....	75
Extent of natural vegetation types (Section 2.3).....	76

3. Ecosystem services	78
3.1. Regulating ES.....	78
3.1.A. Methods of assessment of water-related regulating ES	78
3.1.A1. General modeling framework.....	78
3.1.A2. The InVEST models used.....	79
3.1.A3. Model inputs	79
3.1.A4. Scenarios used for ES modeling and assessment of the ES provided by ecosystems.....	82
3.1.A6. Data preprocessing and assimilation.....	82
3.1.B. Baseflow provision (InVEST SWY).....	84
3.1.B1. Potential ES provided by terrestrial ecosystems	84
3.1.B2. ES potential–supply–use balance	90
3.1.B3. ES changes from 2017 to 2023.....	93
3.1.C. Prevention of soil water erosion and sediment transport to waterbodies (InVEST SDR).....	98
3.1.C1. Potential ES provided by terrestrial ecosystems	98
3.1.C2. Changes in ES potential from 2017 to 2023.....	103
3.1.C3. ES potential – supply/use balance	107
3.1.D. Flood risk mitigation (InVEST Urban Flood Risk Mitigation)	109
3.1.D1. ES provided by terrestrial ecosystems.....	109
3.1.D2. Changes in potential ES (extreme rainfall scenario, 50 mm)	114
3.1.E. Cooling effect of terrestrial ecosystems (InVEST Urban Cooling)	117
3.1.E1. Methodological issues.....	117
3.1.E2. ES provided by terrestrial ecosystems	119
3.1.E3. Potential ES changes from 2017 to 2023	123
3.1.G. Carbon storage in soil and tree biomass.....	124
3.1.G1. Carbon stocks in Armenia, marzes and vegetation zones.....	124
3.1.G2. Changes in carbon stock in tree biomass from 2017 to 2023	126
3.1.H. Pollination	128
3.1.H1. General description of the ecosystem service of pollination and key pollinator groups in Armenia.....	128
3.1.H2. ES assessment.....	133
3.1.I. Regulating ES of protected areas.....	144
ES of seasonal flow regulation and baseflow provision	144
ES of flood risk mitigation	144
ES of prevention of soil erosion and sediment transport into waterbodies	144
Carbon storage in PAs	146
3.2. Provisioning services	148
3.2.A. Fodder production on natural pastures and hayfields	148
3.2.A1. Provided potential ES.....	148
3.2.A2. Changes in ES capacity from 2017 to 2023.....	150
3.2.A3. ES potential-supply-use balance	151
3.2.B. Wild plants used by humans.....	154
3.2.B1. Edible and culinary plants	154
3.2.B2. Medicinal plants of Armenia	155
3.2.B3. Nectar production by natural vegetation	157
3.2.B4. Aggregate assessment of the ES provided by human-used plants.....	158
3.3. Recreational ES: maximum permissible recreational load	161
3.3.A. General approach to assess ES capacity	161
3.3.B. Maximum permissible number of recreationists for daily weekend recreation in roadside-accessible zones.....	162
3.3.C. Maximum permissible number of hikers in zones accessible from the Transcaucasian Trail	168
3.4. Non-material ES: biodiversity in Armenian culture	173
3.4.A. Ancient times: the sacred power and beauty of Nature	173
3.4.B. Middle ages	174
3.4.C. Animals and plants in Armenian folk culture.....	182
3.4.D. Contemporary art	184
3.5. ES accounting: summary and discussion	185

3.6. Examples of accounting tables.....	188
ES of baseflow provision (Section 3.1.B2)	188
ES of prevention of erosion and sediment export to streams (Section 3.1.C2)	189
ES of flood risk mitigation (Section 3.1.D2).....	190
ES of carbon storage in soil and tree biomass (Section 3.1.G)	190
ES of fodder production in natural pastures and hayfields (Section 3.2.A).....	191
4. Contribution to Global Biodiversity Framework.....	192
5. Data and methodological gaps and recommendations.....	194
5.1. Data and methods for ecosystem extent accounting	194
5.1.A. Land cover data.....	194
5.1.B. Harmonization ecosystem extent accounting with the Government-reported land-cover accounting data.....	195
5.1.C. Detailed ecosystem map.....	195
5.2. Ecosystem condition accounting.....	195
5.3. Data and methods for ecosystem service accounting	196
5.3.A. Data limitations for ES assessment	196
5.3.B. Assessment of the balance between ES potential, demand, and use	196
5.3.C. Challenges in assessing ES supply across different ecosystems.....	196
5.3.D. Integration scoping-level and detailed ES models.....	197
5.3.E. Potential bias in assessing the role of different terrestrial ecosystems in ES provisioning	197
5.3.F. The feasibility of assessing the entire bundle of water-related ES	198
6. Starting data-related steps for launching terrestrial ecosystem accounting.....	200
References.....	201
List of abbreviations.....	206
Appendix.....	207
Appendix 2.1. Brief description of land cover datasets, which were tested and excluded from analysis	207
Appendix 2.1.A. Land cover area difference across marzes: Government-reported data minus areas from LC datasets	210
Appendix 2.3.C1. Full vegetation type transition matrix from 2017 to 2023, km ²	211
Appendix 2.3.C1. Vegetation type transition matrix from 2017 to 2023, % relative to 2017.....	212
Appendix 2.5.B-1. The proportion of natural landscapes in their total area in Armenia, S_{im} %, based on Esri 2023 data.....	213
Appendix 2.5.B-2. Marz importance for conserving all LLCC types in Armenia (the sum of S_i indices for each marz).....	214
Appendix 3.1.A. Coefficients used for InVEST modeling.....	215
Appendix 3.1.B-1. Tables for estimation of ES indicators of baseflow maintenance for vegetation types.....	218
Appendix 3.1.B-2. Volume of water use and losses by RA marzes and Yerevan city, 2022, reported by Armstat, <i>mln.m³</i> ...	221
Appendix 3.1.C-1. Avoided erosion and avoided sediment export across vegetation types and marzes in 2017.....	221
Appendix 3.1.C-2. Changes in per-hectare ES provisioning across vegetation types and marzes from 2017 to 2023	223
Appendix 3.1.E-1. Cooling capacity (CC) in settlements provided by surrounding ecosystems	224
Appendix 3.1.E-2. Effect of surrounding ecosystems on cooling capacity in settlements (CC)	228
Appendix 3.1.E-3. Changes in CC in settlements from 2017 to 2023.....	232
Appendix 3.1.H-1. Area of pollinator habitats across marzes	238
Appendix 3.1.H-2. Sites where pollinator surveys were conducted	238
Appendix 3.1.H-3. Identified taxa of key pollinators across vegetation zones	239
Appendix 3.1.H-4. Area of croplands potentially visited by pollinators.....	241
Appendix 3.2.B1. Edible and culinary plant species.....	242
Appendix 3.2.B2. Medicinal plant species	245
Appendix 3.2.B3. Honey plant species.....	247

Summary

Context and aim

Armenia has begun developing a national accounting system aligned with the UN System of Environmental-Economic Accounting – Ecosystem Accounting (SEEA EA), starting with water accounting. The Governmental Decision on the classification of land cover in RA (2019) initiated the first step toward ecosystem accounting by establishing extent accounts for land-cover classes. To support this move toward establishing national ecosystem accounting, a first version of Ecosystem Accounting Prototype (EA PV1) was created aimed at the following core objectives. The EA PV1 provides physical accounting for ecosystem extent (EE) and 13 main ecosystem services (ES) in Armenia, covering all ES categories—regulating, provisioning, recreational, and intangible (Section 1).

Policy relevance of EA PV1

Data for integration of ecosystem values into economic and environmental decision-making

The total value of ES potential demonstrate their key importance for the economy and population of Armenia (Section 3.5): terrestrial ecosystems provide 93% of rivers' baseflow (2212 million m³/year), ensuring water availability in summer and during droughts, which is critically important for Armenia; ecosystems prevent more than 90% of soil water erosion (140 Mt/year) and over 95% of sediment delivery to streams and water bodies (13 Mt/year), thereby protecting soils and maintaining water quality; ecosystems reduce spring and early summer flood risk by increasing runoff retention by 11% (119 million m³/year) and decreasing quick flow by 32%; forests cool the land surface in summer due to water evaporation, increasing on average cooling capacity by 21%; total carbon stock in soils and tree biomass amounts to 151 MtC; natural grasslands provide fodder for one million of livestock units; wild insects could potentially pollinate almost the entire area of agricultural crops.

Data to support informed biodiversity conservation decision-making

Ecosystem extent accounting (Sections 2.2–2.5) captures diversity of terrestrial ecosystems; assesses ecosystem rarity; tracks changes in ecosystem extent; evaluates the contribution of different regions to the conservation of ecosystem diversity in Armenia. The most widespread natural ecosystems in Armenia are steppe and subalpine meadows exceeding 5,000 km² and 4,000 km² respectively (Section 2.3.A). Desert ecosystems, juniper woodlands, and marshes have the smallest areas : 7, 130 and 270 km², respectively, to есть каждая less than 1% of Armenia's area. (Section 2.3.B). Ecosystem rarity and trends in extent are the two main indicators for compiling the Red List of Ecosystems of Armenia. Total ecosystem extent is greatest in Syunik marz and smallest in Armavir marz, however, Ararat marz is the most important for conserving Armenia's ecosystem diversity, as it contains the country's only desert area (Section 2.3.A).

Data on changes in ecosystem extent help identify threatened ecosystem types, while transition matrices reveal the processes driving these changes. Based on Esri land cover data, the total area of natural ecosystems in Armenia decreased by 578.9 km² (–2.5%). The most significant reductions occurred in meadow-steppe ecosystems (254 km², 8.9% decline relative to their area in 2017). The very small absolute decreases in marshes and deserts correspond to noticeable relative declines of 2.6% and 3%, respectively. The largest losses of natural ecosystems—primarily steppe and meadow-steppe—occurred in the marzes of Shirak, Lori, Gegharkunik, and Aragatsotn. The most extensive land cover transitions were observed for grasslands converted into croplands. In particular, 370 km² of steppes, 270 km² of meadow-steppes, 144 km² of semi-deserts, and 61 km² of subalpine meadows were converted into croplands (Section 2.3.C).

Land-use planning and sustainable ecosystem use to maintain ecosystem services

The contribution of different ecosystem types to ES delivery in Armenia and across marzes and watersheds provides an information base for territorial planning aimed at maintaining key ES. It helps decision-makers identify the ecosystem types that are most important for ES delivery, prioritize areas for ecosystem conservation and restoration, and optimize land-use allocation. For example, for the ES of baseflow provision, subalpine, alpine, and meadow-steppe ecosystems play the most important role, providing the largest annual baseflow volumes (555, 405, and 332 million m³, respectively) (Section 3.1.B). The ES of soil erosion prevention is most effectively provided by forests, which prevent 35 Mt/year of erosion; however, in non-forested regions, grasslands play a critical role. Subalpine, meadow-steppe, steppe, and meadow ecosystems together prevent 85 Mt/year of erosion (Section 3.1.C). The conservation and restoration of habitats

for wild insect pollinators within agricultural landscapes can potentially support pollination across almost the entire area of agricultural crops in Armenia, thereby sustaining the yields of entomophilous crops (Section 3.1.H).

The balance between ES potential (capacity), demand, and current use helps identify areas where ecosystems can meet current and future ES needs, as well as areas of overuse or underuse, and supports informed decision-making on whether ES use should be increased or reduced. For example, the ES of baseflow provisioning is insufficient to meet the needs of the economy and population in two basins—Metsamor and Hrazdan—where water consumption exceeds baseflow volume, while in other watersheds baseflow exceeds water consumption several times (Section 3.1.B2). The ES of sediment export prevention is also most critical in these watersheds, preventing 0.48 and 0.35 Mt/year of sediment from entering water used for consumption (Section 3.1.C3). The ES of forage and fodder production by natural grasslands, assuming an even distribution of livestock across the territory, shows unused potential in all marzes except Armavir. The level of ES use ranges from 10% (Vayots Dzor) to 59% (Ararat) and is sensitive to whether land degradation is taken into account (Section 3.2.A3).

Land-use planning for climate change mitigation

Accounting for the ES of carbon storage (Section 3.1.G) and the ecosystem cooling effect (Section 3.1.E) helps identify priority ecosystems and areas and supports land-use planning aimed at mitigating climate change at both global and local scales. It highlights territories that contribute most to climate regulation and therefore require targeted conservation or sustainable management. It also helps planners avoid decisions that could reduce ecosystem carbon stocks or increase local heat stress. In Armenia, approximately 90% of total carbon stocks are stored in soils, underscoring the importance of soil protection. These stocks are particularly significant in regions and natural zones with high soil carbon content, including mountain grasslands, steppes, grasslands within forest zones, and forests, which contain around 60 tC/ha. Regarding local climate regulation, forests provide cooling of near-surface air during summer. In forested marzes—Tavush, Lori, and Syunik—they increase the cooling capacity of land cover by 77%, 57%, and 36%, respectively, and on average across Armenia by 21% (Section 3.1.E).

Land-use planning for natural hazard risk reduction

Accounting for the ES of flood mitigation and erosion prevention provides an information base for territorial planning aimed at reducing risks associated with flooding and soil erosion. It enables planners to prioritize conservation and restoration measures in areas where the loss of ecosystem functions could lead to increased damage, higher public costs, or greater risks for local communities. Ecosystems reduce quick runoff by an average of 4 mm (–32%) and increase runoff retention by 40 m³/ha (+11%) during extreme spring rainfall, thereby mitigating flood risk. The total runoff retention volume is highest in the marzes of Syunik and Gegharkunik, where mountain grasslands make a substantial contribution, and lowest in Armavir marz. Among vegetation types, steppe and subalpine meadows contribute the most, while open woodlands, deserts, and marshes contribute the least due to their limited extent (Section 3.1.D). Forests are the most effective ecosystems for preventing erosion. All types of woodlands and grasslands, except semi-deserts and deserts, are also highly effective in erosion prevention. The highest rates of total avoided erosion were recorded in the marzes of Syunik, Lori, and Tavush, while the lowest values were observed in Armavir (Section 3.1.C).

Impacts of land use on ecosystem services

In the EA PV1, changes in ES were estimated as a result of land-cover change. The overall 2.5% reduction in the extent of natural ecosystems from 2017 to 2023 led to a 0.5–2.7% decline in the potential of all quantitatively assessed ES. The most affected ES were carbon storage (–2.7%), flood mitigation (–2.3%), baseflow provisioning (–2.2%), and fodder production (–2.1%) (Section 3.5). These results clearly demonstrate how changes in ecosystem extent directly affect both the overall supply of ES and their spatial distribution. Such information is essential for planning and prioritizing measures aimed at maintaining or enhancing ecosystem benefits for communities and economic sectors across Armenia.

International reporting and integration

The EA PV1 is aligned with the overarching principles and supports Armenia's integration into the main global and international processes in the fields of ecosystem accounting and biodiversity protection. The EA PV1 includes indicators and maps consistent with the frameworks of the following international initiatives:

- System of Environmental-Economic Accounting — Ecosystem Accounting (SEEA EA) - ecosystem extent and ecosystem services accounting (Sections 2 and 3);
- Integrated Natural Capital Accounting in the European Union (EU INCA) - ecosystem service accounting (Section 3), subsections about ES potential-use balance;
- Convention on Biological Diversity (CBD) and Global Biodiversity Framework (GBF) - ecosystem extent and ecosystem services accounting (Section 4);
- Global Ecosystem Atlas (GEA) – the map of ecosystems (Section 2.7);

110 - Red List of Ecosystems (RLE) of International Union for Conservation of Nature (IUCN) - extent of ecosystems (Section 2.3).
111

112 **Data and methodological gaps for initiating ecosystem accounting in Armenia**

113

114 **Lack of a reliable, regularly updated national land cover dataset.** Global datasets show discrepancies with
115 government-reported data of about 20% of the country's area and contain errors (Section 5.1.A). For EA PV1, the Esri
116 dataset was selected, as it enables the assessment of changes in ecosystem extent (EE) and ecosystem services (ES)
117 between 2017 and 2023. Government-reported land cover data currently lack digital maps and therefore cannot support
118 ES GIS modelling or the construction of land cover transition matrices, as recommended by the SEEA EA (Section 5.1.B).
119

120 **Absence of a detailed ecosystem map.** EA PV1 relies on a generalized vegetation map developed based on previous
121 academic studies by Armenian geobotanists. A consistent, high-resolution national ecosystem map is needed for accurate
122 ecosystem extent accounting and to support informed biodiversity conservation decision-making (Section 5.1.C).
123

124 **Data gaps for ES modelling and mapping.** Some data required for ES assessment were sourced from global databases
125 and the literature due to the lack of availability in national open-access databases. Limited national monitoring data and
126 missing information (e.g., on ES use) constrain comprehensive assessment. ES modelling for national ecosystem
127 accounting should be based on data verified through in situ measurements from Armenia's hydrometeorological,
128 geodesy, and cartography services (Section 5.3.A).
129

130 **Scoping-level ES models.** The scoping-level ES models used in the EA PV1 are appropriate at this stage; however, more
131 detailed models are required for comprehensive ES accounting that reflects the diversity of natural conditions and
132 economic factors in Armenia (Section 5.3.D).
133

134 **Main initial data-related steps for launching ecosystem accounting in Armenia**

135 The launch of the first phase of ecosystem accounting requires only standard, commonly available hardware and
136 software. The initial data-related steps for terrestrial ecosystem accounting are as follows (Section 6):

- 137 • **Establish a national land cover dataset**, verified using Armenian data and harmonized with official land-cover
138 statistics, including a clearly defined methodology for its updating based on satellite imagery from global sources
139 and official data from Armenia.
- 140 • **Produce a detailed national ecosystem map** using GIS-based methods, land cover data, and the Ecological Land
141 Units (ELU) approach.
- 142 • **Compile national and regional databases of ES modelling coefficients**, containing nationally validated data on
143 natural conditions based on in situ measurements in Armenia, as well as statistical and survey data on ES use
144 and demand.
- 145 • **Design a framework for integrating scoping-stage ES models** (InVEST and others) with advanced hydrological
146 and meteorological models to account for the high diversity of natural conditions in Armenia.
147

1. Introduction: the aim and general methodology of the project

1.1. Aim of the project

The aim of the project is to create a Prototype of national ecosystem accounting (EA) for natural terrestrial ecosystems of Armenia in physical terms, in accordance with the System of Environmental-Economic Accounting framework (SEEA EA) (United Nations, 2021), and to provide technical recommendations for initiating physical EA in Armenia.

The project is being implemented by Biodiversity Conservation Center BCC Armenia jointly with the Leibniz Institute of Ecological Urban and Regional Development (IOER) with the participation of experts from leading scientific organizations in Armenia. The project is funded by the German Federal Environment Ministry’s Advisory Assistance Program (AAP) for environmental protection in the countries of Central and Eastern Europe, the Caucasus and Central Asia and other countries neighboring the European Union. It is supervised by the Federal Agency for Nature Conservation (BfN) and the German Environment Agency (UBA). The project is carried out in Armenian and English languages.

1.2. System of Environmental-Economic Accounting—Ecosystem Accounting (SEEA EA)

Sustainable development is impossible without an understanding of ecosystems, the services that they provide to humans, and the changes they undergo. This challenge is addressed by EA, which has been rapidly evolving in recent years. In 2024, 94 countries conducted accounting—to varying extents—under SEEA Central Framework (SEEA CF) and 53 countries also compile the SEEA Ecosystem Accounting (SEEA EA) and/or thematic accounts. (SEEA Global assessment, 2024)¹. In particular, the INCA project has launched a pilot EA for EU countries (European Commission, 2021).

The EA constitutes a statistical framework for organizing data about ecosystems and ecosystem services, tracking changes in them. EA data are needed for the following tasks: to make visible and understandable to people the material and non-material contribution of living nature to their well-being; to assess and track the state of ecosystems and their services; to identify and track the impact of human activities on the state of ecosystems and their services; to provide an information basis for decision-making in order to maintain and sustainably use ecosystems and ecosystem services.

The SEEA EA is built on a few core accounts (Figure 1.2-1):

1. Ecosystem extent (EE) accounts record the size of ecosystems of different types and changes in it. Ecosystem extent is usually measured in terms of spatial area but may also be measured in terms of length or volume. Ecosystem extent is accounted for within ecosystem accounting areas (EAAs)—e.g., a nation, province, river basin, or protected area—by ecosystem type.
2. Ecosystem condition accounts record the condition of ecosystems and the changes in it providing valuable information on the health of ecosystems.
3. & 4. Ecosystem services (ES) accounts (physical and monetary) record the supply of ES by ecosystems and the use of those ES by economic units, including households.
5. Monetary ecosystem asset accounts record on stocks and changes in stocks of ecosystem assets.

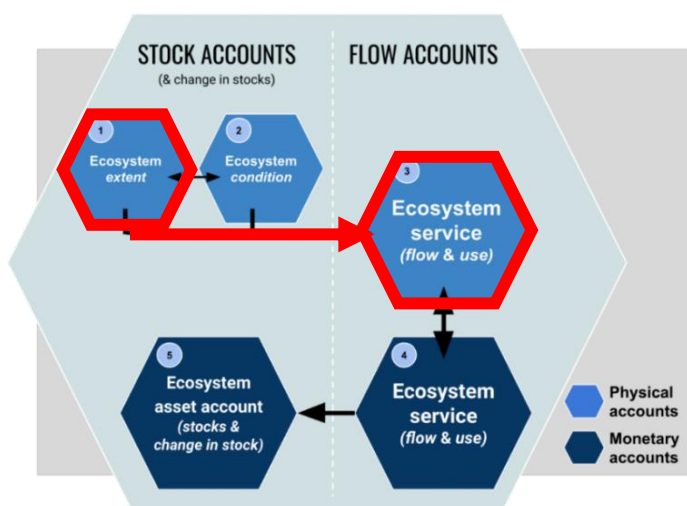

Figure 1.2-1: Ecosystem accounts and how they relate to each other (<https://seea.un.org/ecosystem-accounting>). Accounts included in PV1 are highlighted in red.

¹ SEEA Global assessment, 2024. <https://seea.un.org/content/global-assessment-environmental-economic-accounting>

1.3. Ecosystem accounting in Armenia

Currently, Armenia is among the 94 countries that apply the SEEA Central Framework and among the 67 countries that publish at least one account on a regular basis (Stage III)². As indicated by the 2024 SEEA Global Assessment³ Armenia compiles water accounts—specifically, physical and monetary supply-and-use tables for water⁴ — which are published on the website of Statistical Committee of the Republic of Armenia (Armstat)⁵

As stated on the SEEA website, as of 2024 Armenia has not yet begun compiling ecosystem accounts. Nevertheless, important steps toward ecosystem accounting have already been taken, both at the government level and by Armenian scientific community.

The Decision of the Government of the Republic of Armenia in April 11, 2019 n 431-n⁶ “On approval of the procedure for classification of the land cover of the Republic of Armenia” set out the framework for the annual accounting of the areas of the main land-cover classes in Armenia, based on the results of current land accounting in communities, marzes (provinces), and nationwide. Accounts should be compiled for the following land-cover classes: Cultivated lands; Grasslands; Tree-covered areas; Shrub-covered areas; Water covered areas; Vegetation-free areas. Since then, statistical data on the areas of these land-cover classes have been publicly available at the marz level and for Armenia as a whole (see Section 2.2). Annual accounting of land-cover class areas is a fundamentally important step toward ecosystem accounting. However, for a modern, comprehensive accounting of ecosystems—as carriers of biodiversity and providers of ecosystem services—it is necessary to have not only statistical tables but also digital maps, which are not yet available for the entire territory of Armenia.

In recent years, attention to Armenia’s ES has been increasing (Shahnazaryan, Harutyunyan, 2017), including water-regulating ES (Introduction..., 2011), soil erosion prevention (GIZ EcoServe Project, 2014; 2016; Pietsch et al., 2019) and cultural ES (Asatryan et al., 2024; Pietsch et al., 2019). However, quantitative assessment and mapping of ES at the national level in Armenia have not yet been carried out.

1.4. Ecosystem Accounting Prototype Version 1: content and methodology

The EA Prototype Version 1 (EA PV1) follows the recommendations of SEEA-EA (United Nations, 2021) and the European INCA project on ecosystem accounting (Eurostat, 2024 a,b; Vallecillo et al., 2019) and covers physical EE and ES account (highlighted in red in the Figure 1.2-1). Monetary accounts are not included in the project. The EA PV1 includes statistical tables and maps presenting EE and ES indicators, as well as a short description of the main results, data sources used, the assessment methodology.

The EA PV1 was created based on currently available data - published open statistical, cartographic and scientific data for Armenia, as well as global databases. The project did not include the collection of primary data or specialized scientific research. In cases where national data is not available, the assessment was made based on global databases or expert estimates. Therefore, EA PV1 presents a simplified version of EA, including only those components that could be assessed within the project framework using available open global and national data. Nevertheless, EA PV1 demonstrates the main approaches to EE and ES accounting, including examples of accounting tables in the UN-recommended format.

Natural terrestrial ecosystems are understood as all areas excluding anthropogenic areas that are created and managed by humans — namely, built-up areas and cropland. Water bodies and aquatic ecosystems were excluded from the analysis because the factors determining their condition and dynamics differ significantly from those affecting terrestrial ecosystems. Agroecosystems on cultivated lands and ecosystems within settlements were excluded from the accounts. Yerevan was also excluded from the accounts and only marzes were involved in marz level.

EE and ES accounts were compiled for the following ecosystem accounting areas (EAA):

- At the national and marz levels, using Armenia’s national and marz boundaries from the Interactive Forest Atlas of Armenia⁷ website;
- Main watersheds (HydroSHEDS),
- Landscape zones (Interactive Forest Atlas of Armenia);
- Vegetation zones based on the map produced under the project (Section 2.3)
- For methodological purposes, we also developed sample EE and ES accounts for Armenia’s protected areas (PAs) (Sections 2.6 and 3.1.D).

² <https://seea.un.org/content/global-assessment-environmental-economic-accounting>

³ <https://seea.un.org/content/2024-global-assessment>

⁴ https://seea.un.org/sites/seea.un.org/files/files/Global_assessment/2024_GA/global_assessment_for_website_2024_final.xlsx

⁵ PxWeb - Select table

⁶ <https://www.arlis.am/hy/acts/135631>

⁷ <https://forestatlas.am/>

To map and assess EE and ES we used the 10 m-resolution Esri land cover dataset⁸ to exclude built-up areas and cropland from the accounts, as well to delineate forest and non-forest areas. The Esri land-cover dataset was selected as an EA component following tests of several land-cover datasets, which indicated that Esri data closely align with state statistics on agricultural areas in Armenia and enable us to demonstrate the dynamics of ecosystem extent and ES (Section 2.1). To demonstrate the ability of the EA Prototype to track changes in ecosystem extent and ES, we selected two reference years—2017 and 2023—based on the Esri land cover dataset.

For data preprocessing, EE and ES mapping, and GIS analysis we used the open source QGIS application and custom Python scripts. For assessing and mapping water-related regulating services, we used models from the InVEST GIS tool (Section 3.1.A).

Ecosystem extent

At present, Armenia lacks a detailed, regularly updated digital ecosystem map. Therefore, to support an informed choice of the most suitable EE accounting methodology, we tested the feasibility of compiling EE accounts using different approaches to ecosystem classification:

- The most generalized division of ecosystems by land-cover classes, that is, accounting for the extent of natural land-cover classes (Section 2.2);
- Types of natural vegetation as a proxy of terrestrial ecosystems (Section 2.3)
- Types of natural landscapes as a proxy of terrestrial ecosystems (Section 2.4);
- Intersections of landscape zones land cover classes (LLCC) as a proxy of terrestrial ecosystems (Section 2.5).

SEEA EA recommends compiling national ecosystem accounts in accordance with the national ecosystem classification. Accordingly, we used the classification of landscape and vegetation zones adopted by the academic community of Armenia. Subsequently, all results can be reclassified into the SEEA-approved IUCN GET system level 3 for the purpose of international comparison.

The source land cover maps were provided as raster data in GeoTIFF format, while the layers of climatic, landscape, and vegetation zones were delivered as vector data in GeoPackage format. To combine this data, first, the vector maps were rasterized in QGIS to match the coordinate reference system, spatial extent, and resolution of the land cover rasters, ensuring all maps shared the same pixel-wise structure. Next, the resulting raster maps with zonal boundaries were combined with the land cover raster maps through two steps: (i) the pixel values of the land cover map were multiplied by 100, and (ii) these adjusted values were added to the corresponding pixel values of a zonal map, resulting in a unified raster. For example, a final pixel value of 204 indicates that the pixel has a land cover value of two (e.g., trees) and a landscape value of four (e.g., low and middle mountain forest). This combined raster was then analyzed using a vector layer containing marz or watershed borders. The Zonal Histogram tool in QGIS was employed to count the occurrences of each unique raster value within the polygonal zones of the marzes or watersheds. The output layer, which contained statistics on the number of pixels with unique raster value within each marz or watershed, was exported in tabular format for further statistical analysis.

The area was calculated based on an average pixel size of 100 m². The mismatch between the total area of the country and marzes derived from land cover data and the official figures is due to discrepancies in the boundaries of the digital maps used, as well as unaccounted variation in pixel area caused by terrain across Armenia. These discrepancies should be addressed in the development of a national ecosystem extent accounting in Armenia.

SEEA EA recommends annual accounting of ecosystem extent. However, in Armenia, according to the Decision of the Government of the Republic of Armenia in April 11, 2019 n 431-n⁹, annual data collection is currently established only for statistics on the areas of land-cover classes, without publicly accessible digital maps (see Section 2.2.A). Therefore, for methodological purposes, and to demonstrate ability of EA to track ecosystem dynamics, we used Esri Land Cover data for 2017 and 2023.

Also, we could not fully comply with the SEEA-EA recommendations to distinguish changes in ecosystem extent between managed and unmanaged changes because of the lack of data. However, for a substantial share of the land-cover changes detected by the Esri land cover data—specifically the expansion of cropland and built area—it is evident that these are managed changes. Therefore, in the final accounting tables, this driver is indicated for these cases; for the other cases, the driver is recorded as “not determined.”

EE account by economic units was made for marzes.

Transition matrices (change matrices) were produced on the base of GIS-analysis for both land-cover classes and vegetation types. The land-cover class matrix directly captures class-to-class transitions between the Esri 2017 and 2023 datasets. The vegetation-type transition matrix also shows how areas of vegetation zones transitioned into land-cover

⁸ <https://livingatlas.arcgis.com/en/home/>

⁹ <https://www.arlis.am/hy/acts/135631>

classes (e.g., steppe vegetation converting to croplands, built-up, bare ground, or tree cover, and vice versa). Zone-to-zone vegetation transitions are not recorded in the EA PV1, because the zone boundaries did not change.

Ecosystem services

In the SEEA-EA (United Nations, 2024), ES are understood as the contributions of ecosystems to benefits used in economic and other human activities. Final ES are those in which the user of the service is an economic unit; thus, every final ES represents a flow between an ecosystem asset and an economic unit. Intermediate ES are those in which the user is an ecosystem asset and there is a connection to the supply of final ES. Benefits are the goods and services that are ultimately used and enjoyed by people and society. As applied in ecosystem accounting, a benefit will reflect a gain or positive contribution to well-being arising from the use of ecosystem services.

The EA PV1 accounts for 13 final ES across all final ES categories: provisioning, regulating, recreational and intangible (Table 1.4-1). We did not consider intermediate ES. The full list of ES mentioned in SEEA--EA is presented in Table 1.4-2.

Table 1.4-1. List of ES assessed in the EA PV1

Ecosystem services			Section
Provisioning ES	1) Production of forage and fodder for cultivated livestock by natural grasslands	Potential Supply=Use	3.2.A
	2) Wild plants biomass production: edible and culinary plants	Potential (score)	3.2.B
	3) Wild plants biomass production: medicinal plants		
	4) Nectar production by wild plants for honey bees to produce honey		
Regulating ES	5) Global climate regulation: carbon storage in soil and tree biomass	Potential	3.1.G
	6) Local climate regulation: ecosystem effect on surface temperature	Potential	3.1.E
	7) Prevention of soil erosion	Potential Supply=Use	3.1.C
	8) Prevention of sediment export to streams		
	9) Baseflow provision	Potential Supply=Use	3.1.B
	10) Flood risk mitigation	Potential	3.1.D
11) Crop pollination by wild insects	Potential (score)	3.1.H	
Recreational ES	12) Natural conditions for recreation	Potential	3.3
Non-material ES	13) Importance of biodiversity for Armenian culture	Potential (description)	3.4

The EA PV1 focuses on the natural conditions and processes underpinning ES provision, while excluding societal factors of ES supply and use, ecosystem management and other labor and resource inputs associated with ES supply and use, ES import-export, as well as ES contributions to the System of National Accounts.

The SEEA EA terminology concerning ES volume provided by ecosystems differs slightly from that commonly used in literature. In much of the ES literature, the term supply is used to refer to an ecosystem’s potential or capacity to supply ES irrespective of use. In the SEEA-EA framework, ES physical accounts record the supply of ES by ecosystems and the use of ES by economic units (businesses, governments and households). ES are recorded as flows between ecosystem assets and economic units. The measures of supply and use are equivalent and will be equal to the actual flow between the ecosystem asset and people. In other words, the total volume of ES supplied by different ecosystems equals the total volume of ES used by different users. These indicators show how ES produced by different ecosystems are redistributed among different users. However, they do not reveal management-relevant aspects — such as the degree of ES use (including overuse and the potential to scale up use), or the extent to which the existing ES flow meets demand. These aspects can be assessed on the base of ecosystem potential to provide ES (capacity) which is understood as the ability of an ecosystem to generate an ES at the highest yield or use level that does not negatively affect the future supply of the same or other ES from that ecosystem. SEEA EA proposes keeping separate accounts for ecosystem capacity. INCA project proposes to include in accounting tables indicators of ES potential (capacity), ES demand, actual ES flow which is equal to ES supply-use, and unmet demand (Vallecillo et al., 2019).

Given the pivotal importance of the ecosystem potential (capacity) indicator for ecosystem management, we adopted it in PV 1 as the primary basis for ES assessment. Ecosystem potential can be evaluated from natural factors and the biological characteristics of ecosystems. Such data were available for all 12 ES assessed quantitatively or by scoring (the exception is the ES “biodiversity value for Armenia’s culture,” which we only described with examples). The ecosystem potential (capacity) is relevant both for ES that can be overused (provisioning and recreational services) and for regulating ES, which cannot be directly overused but may be insufficient to meet human demand. The capacity was assessed for the remaining 12 ES (Table 1.4-2).

The assessment of ES use requires socio-economic data, which was available for only six ES. In four cases the ES users (economic units) were the marzes for the grazed biomass production ES (ES 1 in Table 1-1), two water-regulating ES (ES

8 and 9), and pollination (ES 11); in one case—settlements for the ecosystems’ cooling effect (ES 6); and in one case—Protected Areas for the ES of natural conditions for hiking in PAs (ES 12). Benefits derived from assessed ES are described in Table 1.4-3.

Changes in ES were assessed only in terms of their potential/capacity, based on land-cover changes between 2017 and 2023. The effects of climate change were not taken into account. An assessment of changes in ES use and supply was not conducted because data on ES use for 2017 are unavailable.

Table 1.4-2. List of ES from SEEA EA, with those included in the EA PV1 highlighted in **bold italics**.

Ecosystem service	Indicators of potential ES (capacity)	Indicators of ES supply and use	Assessing method	Section	
Provisioning ES					
Biomass provisioning	Crop provisioning ES	NA (ES provided by non-natural agroecosystems)			
	1) Grazed biomass provisioning ES: production of fodder for cultivated livestock by natural grasslands	Maximum allowable stocking rate (LU/ha)	Current number of cattle, sheep and goats (LU/ha)	Mapping, GIS- and descriptive data analysis	3.2.A
	Livestock provisioning ES	NA (ES provided by non-natural agroecosystems)			
	Aquaculture provisioning ES	NA (ES provided by non-natural aquatic systems)			
	Wood provisioning ES	NA (lack of open statistical data)			
	Wild fish and other natural aquatic biomass provisioning ES	NA (lack of open statistical data)			
	Wild plants biomass provisioning ES: 2) Culinary plants 3) Medicinal plants	Score-based assessment	NA	Mapping, GIS- and descriptive data analysis	3.2.B
Wild animals and other biomass provisioning ES	NA (lack of open statistical data)				
Genetic material	NA (limited project resources and time)				
Water supply	Water supply is accounted for ES seasonal water flow regulation and baseflow maintenance				
Other provisioning ES	4) Nectar production by wild melliferous plants for honeybees to produce honey	Score-based assessment	NA	Mapping, GIS- and descriptive data analysis	3.2.B
Regulating and maintenance ES					
Global climate regulation	5) Storage of carbon in ecosystems in soil and tree biomass	Carbon content, tC/ha Carbon stock, Mtc	NA	Mapping, GIS- and descriptive data analysis	3.1.G
	Other global climate regulation ES	NA (limited project resources and time)			
Rainfall pattern regulation	NA (limited project resources and time)				
Local (micro and meso) climate regulation	6) Effect of natural ecosystems on surface temperature	Cooling capacity of natural ecosystems	NA	GIS-modeling with the InVEST Urban Cooling model	3.1.E
Air filtration	NA (ES is most important for urban ecosystems)				
Soil quality regulation	NA (limited project resources and time)				
Soil and sediment retention	7) Prevention of soil erosion; 8) Prevention of ediment export to streams	Avoided erosion and avoided sediment export, t/ha/year; Mt/year	Amount of sediment avoided in the volume of water consumed, t/year	GIS-modeling with the InVEST Sediment Delivery Ratio model	3.1.C
	Landslide mitigation ES	NA (limited project resources and time)			
Solid waste remediation	NA (limited project resources and time)				
Water purification	Retention and breakdown of nutrients and other pollutants	NA (lack of open statistical data)			
Water flow	9) Regulation of seasonal	Ecosystem effect on	Water	GIS-modeling with	3.1.B

regulation	river flow and baseflow maintenance	total river flow, baseflow and quick flow, mm; m ³	consumption, m ³	the InVEST Seasonal Water Yield model	
Flood control	Coastal protection ES	NA (limited project resources and time)			
	10) Runoff retention by ecosystems under average and extreme rainfall	Ecosystem runoff retention, m ³	NA	GIS-modeling with the InVEST Urban Flood Risk Mitigation model	3.1.D
Storm mitigation	NA (limited project resources and time)				
Noise attenuation	NA (ES is most important for urban ecosystems)				
Pollination	11) Crop pollination by wild insects	Score-based assessment	Score-based assessment	Mapping, GIS-analysis	3.1.H
Biological control	Pest control services	NA (limited project resources and time)			
	Disease control services	NA (limited project resources and time)			
Nursery population and habitat maintenance	NA (Intermediate ES)				
Cultural (recreational and non-material) services					
Recreational ES	12) Natural conditions for recreation	Maximum allowable number of recreationists (persons/year)	NA	Mapping, GIS-analysis	3.3
Visual amenity	NA (limited project resources and time)				
Education, scientific and research ES	NA (limited project resources and time)				
Spiritual, artistic and symbolic ES	13) Importance of biodiversity for Armenian culture	Description			3.4

Table 1.4-3. Initial logic chains for assessed ES

ES	Ecosystem types	Factors determining supply		Factors determining use	Metrics for the ES	Benefits (description)	Main users and beneficiaries
		Ecological	Soci-et al				
Grazed biomass provisioning	Different types of grasslands (alpine, subalpine, steppe, semidesert)	Vegetation zone	NA	Number of cattle, sheep and goats in marzes	Stocking rate (LU/ha)	Livestock and livestock products (e.g., meat, milk, eggs, wool) (SNA benefits)	Agriculture in marzes
Wild edible and culinary plants biomass provisioning	Forests and different types of grasslands (alpine, subalpine, steppe, semidesert)	Vegetation zone	NA	NA	Score-based assessment	Harvested edible and culinary plants (non-SNA benefit)	NA
Wild medicinal plants biomass provisioning						Harvested medicinal plants (non-SNA benefit)	
Wild-plant nectar provisioning						Honey from domestic bees (non-SNA benefit)	
Global climate regulation – C storage in ecosystems	All natural terrestrial ecosystems	The global map of C content in soil Average C content in tree biomass in Armenia	NA		Tons of carbon	Reduced concentrations CO ₂ in the atmosphere leading to less climate change	NA
Local climate regulation - ecosystem effect on surface temperature	Forests and grasslands	Climate zone		The size and shape of settlements	Cooling capacity	Improved living conditions and economic production (non-SNA benefit)	Population in settlements
Preventing soil erosion	Forests and different types of grasslands (alpine, subalpine, steppe, semidesert)	Topology; soil type; climate conditions, land cover class (grassland or trees)	NA	NA	Tons of avoided erosion	Soil stability (non-SNA benefit)	NA
Preventing of sediment transport to streams						Water quality improving	Economy of marzes
Seasonal flow regulation and baseflow maintenance						Water supply	Economy of marzes
Flood risk mitigation	Forests and	Soil type; climate			Runoff retention,	Mitigation of flood	NA

(runoff retention)	grasslands	conditions, land cover class (grassland or trees)		mm	damage	
Pollination	Forests and different types of grasslands (alpine, subalpine, steppe, semidesert)	Abundance and activity of wild pollinators in different vegetation zones	The share of entomophilous crops; the distance from natural ecosystems	Score-based assessment	High yield of insect-pollinated crops and cost savings on alternative pollination (SNA benefit)	Economy of marzes
Recreation-related services	Forests and different types of grasslands (alpine, subalpine, steppe, semidesert)	Vegetation zone	The area of recreationist distribution; the number of recreationists	Number of recreationists	Physical and mental health; enjoyment (non-SNA benefit)	Tourism service
Cultural importance of biodiversity	Iconic animal and plant species, natural landscapes	-	NA	Descriptive text and images	Understanding of national culture	NA

To determine ES volume provided by ecosystems, we proceeded from the following understanding of baseline conditions — situations in which ecosystems are absent and ES is not performed (Table 1.4-4). For most ES, it was assumed that in the absence of ecosystems ES would be entirely absent (no/zero ES). For water-related regulating ES, which are partly performed by the bare land surface without living cover, the baseline conditions were represented by a “bare ground” scenario, where all natural ecosystems were replaced with bare ground (see Section 3.1.A).

Table 1.4-4 Baselines for assessed ES

ES	Baseline
Grazed biomass provisioning	No/zero biomass provisioning
Wild edible and culinary plants biomass provisioning	
Wild medicinal plants biomass provisioning	
Wild-plant nectar provisioning	
Global climate regulation – C storage in ecosystems	
Local climate regulation - ecosystem effect on surface temperature	Bare ground scenario
Preventing soil erosion	
Preventing of sediment transport to streams	
Seasonal flow regulation and baseflow maintenance	
Flood risk mitigation (runoff retention)	
Pollination	No/zero pollination
Recreation-related services	No/zero ES

Changes in ES were assessed using two approaches:

- for ES modelled in InVEST, changes were calculated as differences between ES indicator values derived from maps based on land cover data for 2017 and 2023;
- for all ES, indicators were first assigned to each ecosystem type, after which changes in total ES values at the marz and national levels were estimated based on changes in the extent of land cover classes (Section 2.2.B) and ecosystems (Section 2.3.C) between 2017 and 2023.

2. Ecosystem extent

2.1. Testing available land cover datasets and dataset selection for PV1

The data for Armenia from the following five publicly available global land cover datasets were tested (Fig. 2.1-1): 1) Dynamic World; 2) Esri Land Cover; 3) ESA WorldCover; 4) GLC_FCS30D; 5) GLAD Global Land Cover and Land Use Change. The following datasets were excluded from analysis: MODIS MCD12Q1; Copernicus Global Land Cover; ESA CCI/C3S Global Land Cover product; Globeland30; GlobCover; World Terrestrial Ecosystems; The Global Land Cover by National Mapping Organizations (GLCNMO). See short dataset description in the Appendix 2.1.

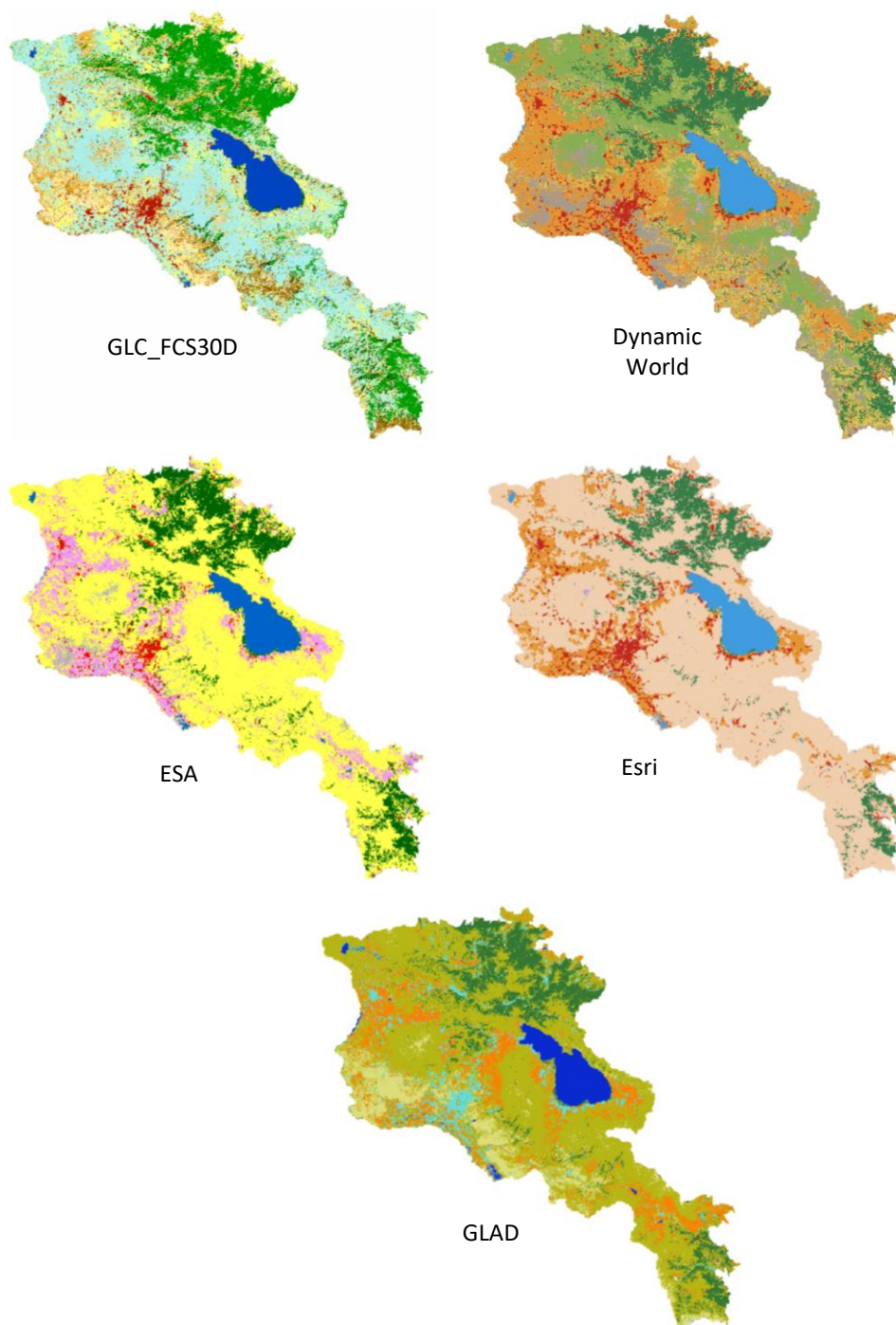

Figure 2.1-1. Tested land cover datasets. For detailed maps see Project Web GIS, section maps in the project Web GIS Section Land cover datasets examination (<https://bccarmenia.nextgis.com/resource/69/display?panel=none>)

2.1.A. Area of land cover classes in the tested datasets

To ensure dataset comparability, all tested land cover datasets and Governmental data on land cover area were generalized into five land cover classes: 1) trees; 2) non-woody natural areas; 3) water, wetlands, flooded vegetation; 4) crops; 5) built-up areas.

The Decision of the Government of the Republic of Armenia on April 11, 2019 defined the following land cover classes for national accounting: Cultivated lands; Grasslands; Tree-covered areas; Shrub-covered areas; Water covered areas; Vegetation-free areas. The more detailed disaggregation of land cover classes by land fund categories provided in the Government-reported data enables the separation of vegetation-free anthropogenic areas, i.e., built-up areas from natural ones and makes it possible to compare Governmental data and land cover datasets. How to classify grasslands and cultivated lands located within settlement boundaries is a question that needs to be addressed in order to harmonize satellite-based land cover classifications with official land cover statistics. At this stage of the analysis, we kept these lands within grasslands and cultivated lands, respectively.

Further, to ensure comparability of tested datasets and Government-reported data three land cover classes - Grasslands, Shrub-covered areas, and Vegetation-free natural areas - were combined into one class Non-woody natural areas. The data for 2022 were used for comparison, as it represents the midpoint between the dates of the tested land cover datasets.

Share of land cover classes in Armenia

GLC_FCS30D landcover data shows very strong excess of cropland area and excess of forest area. The results of the three land cover datasets — Esri, ESA, and GLAD — are similar and show a smaller cropland area and larger grassland area than the Government-reported data. In contrast, the DW dataset shows a larger cropland area and smaller grassland area than the Government data (Fig. 2.1.A-1, 2.1.A-2). Dataset GLC_FCS30D 2022 was excluded from further analysis, as it differed most significantly from all the other datasets and from Government-reported data.

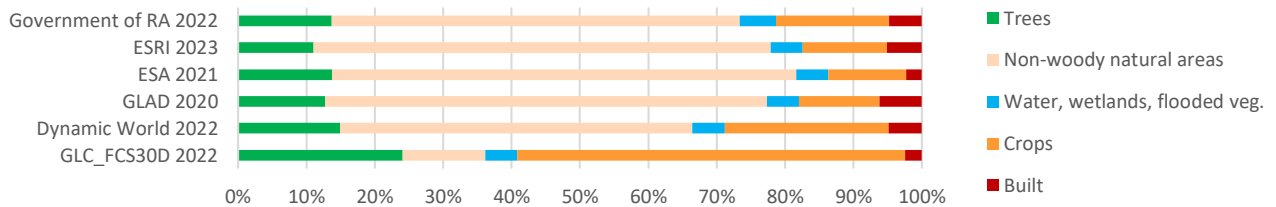

Figure 2.1.A-1. Share of land cover classes in Armenia according the five tested datasets

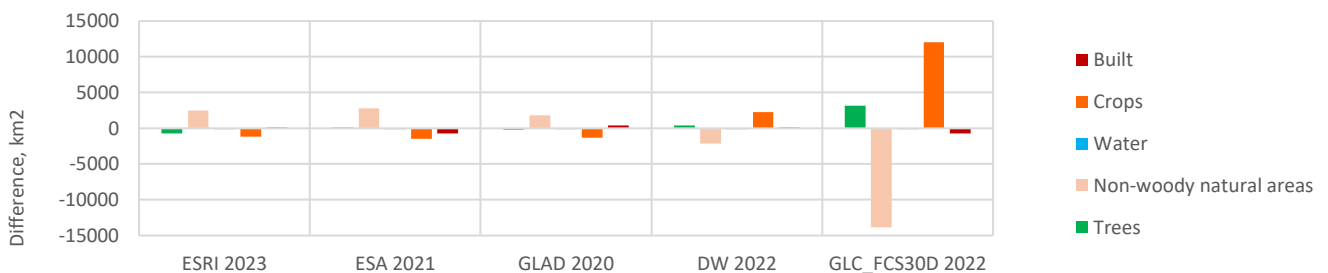

Figure 2.1.A-2. Difference between Government-reported area of land cover classes (2022) and tested datasets

Share of land cover classes across marzes

All four remaining datasets differ significantly from the Government-reported data (Fig. 2.1.A-3). The discrepancies identified at the national level are largely maintained across marzes: Esri, ESA, and GLAD show larger areas of non-woody natural lands and smaller cropland areas compared to the Government data. In contrast, DW shows smaller non-woody areas and larger cropland areas than the Government data (Fig. 2.1.A-4). This shift persists across the majority of marzes (Fig. 2.1.A-4), suggesting that it is systemic and driven by the differences in the methodology used for satellite image classification. Discrepancies between tested datasets and Government data for forest cover and built-up areas are smaller in magnitude and do not follow the pattern observed in the relationship between cropland and non-woody natural areas. The most prominent shifts included for forest area a reduction in the Esri data, and increase in the DW data, as well as for built-up area a reduction in the ESA data and increase in the GLAD data. Differences between the land cover datasets and the Government data in terms of water area are minor and fairly consistent across all datasets — each identifies a slightly smaller water area. A more detailed view of the area differences across the marzes is presented in Appendix 2.1.A.

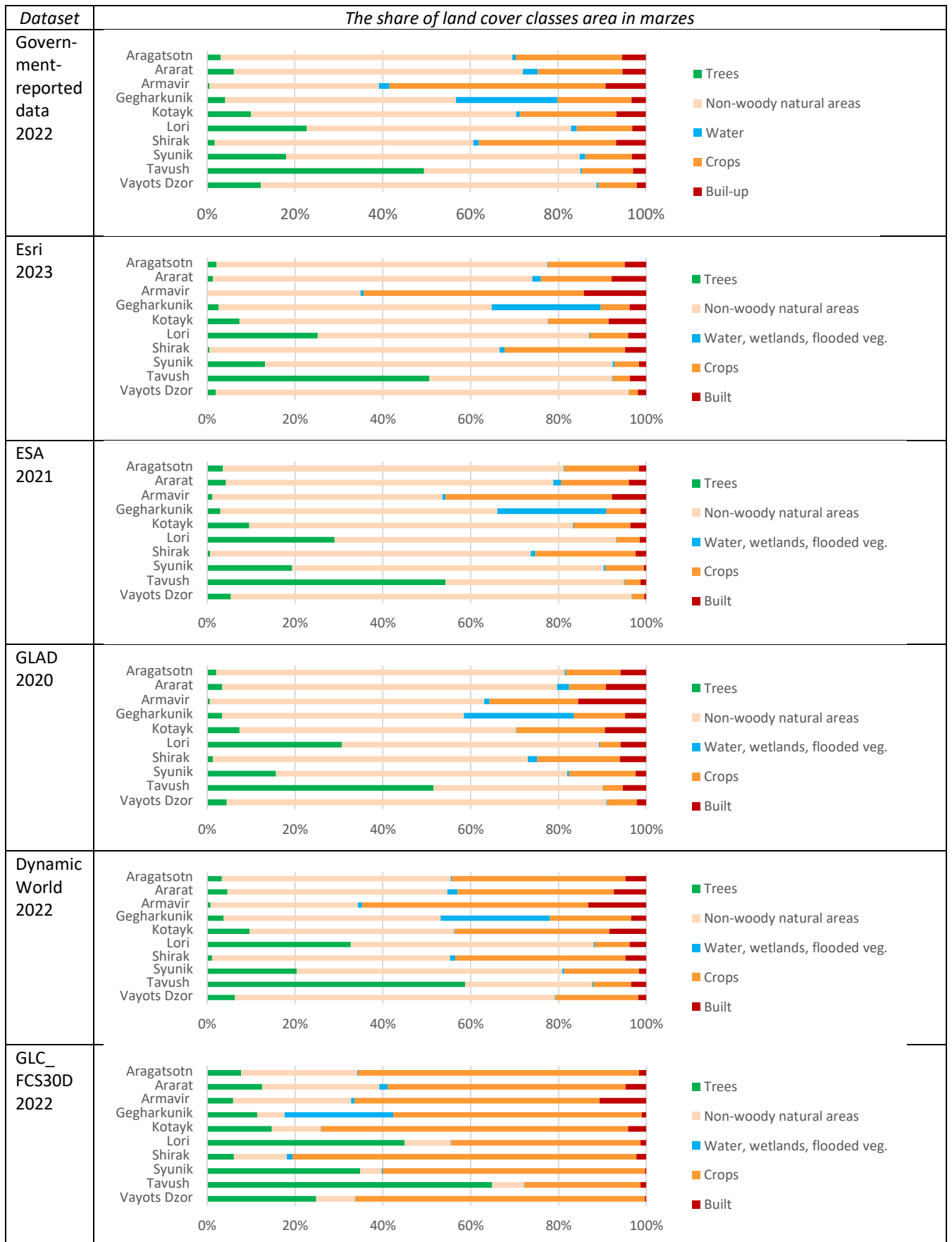

Figure 2.1.A-3. Land cover class shares across marzes according to Government-reported data and tested datasets

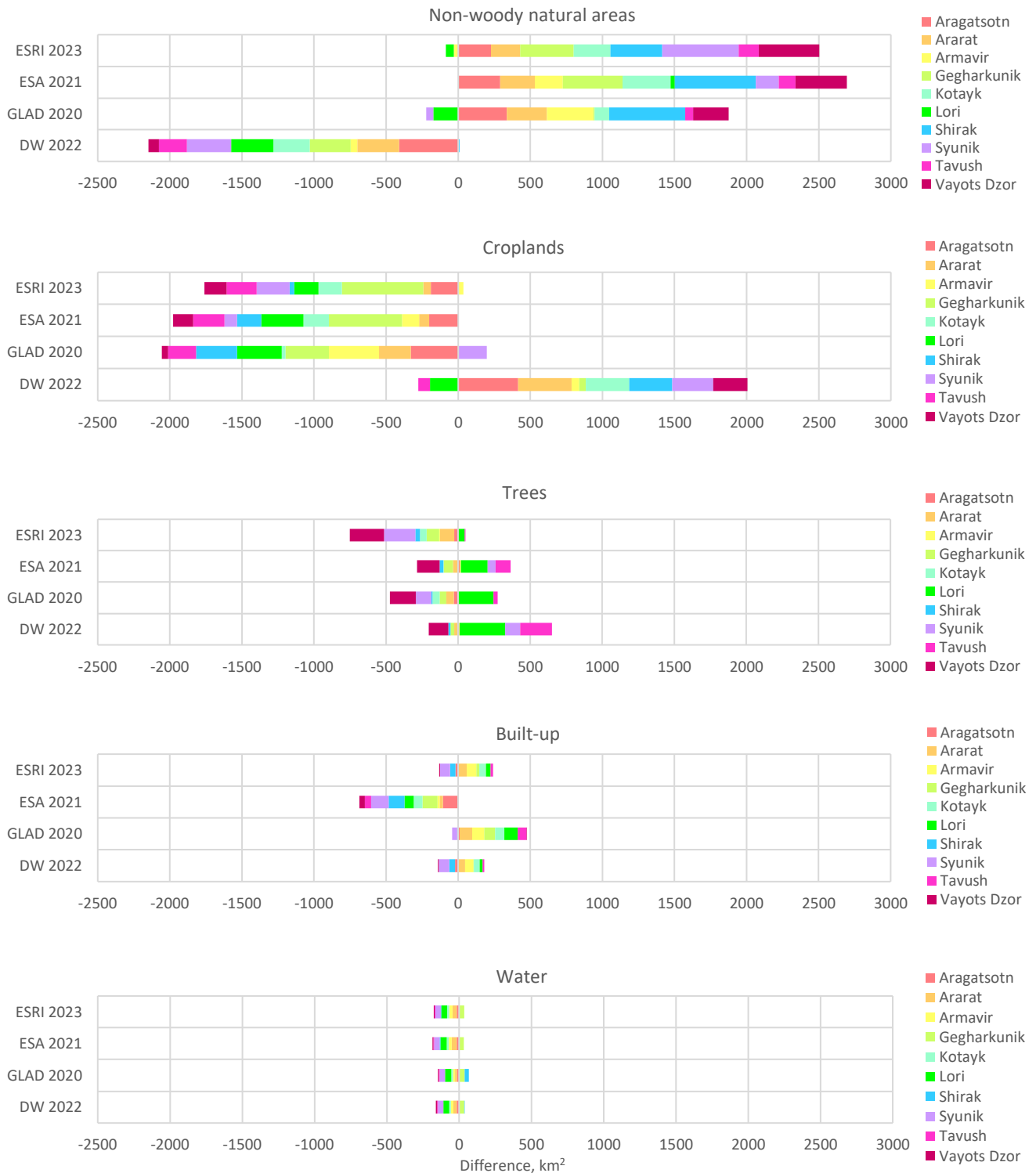

Figure 2.1.A-4. Land cover area difference: Government-reported areas minus areas from tested datasets. Differences between tested datasets and Government-reported data in marzes are shown in different colors. Provincial differences for each land cover class are combined into a single bar to show the total deviation from the Government-reported data.

The absolute discrepancy (km²) is largest for croplands and grasslands, while in relative terms (percentage relative to Government-reported data), it is greatest for croplands and built-up areas (Figure 2.1.A-5).

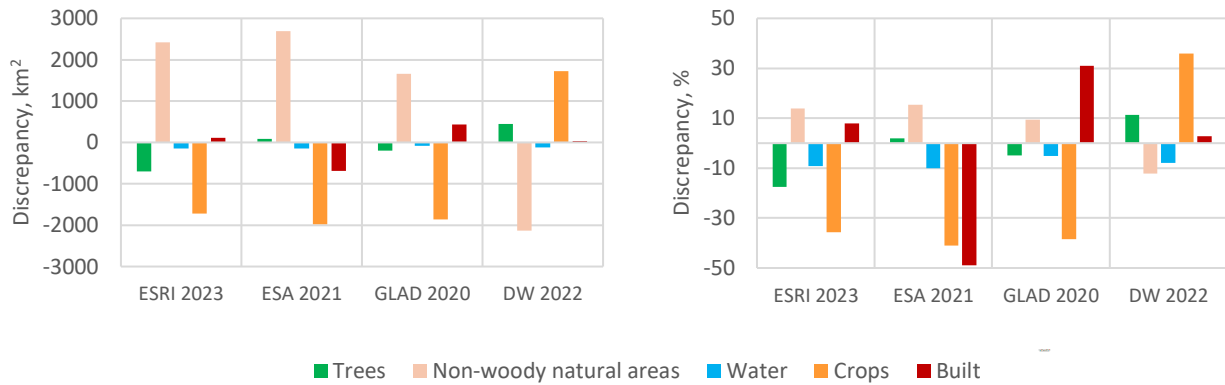

Figure 2.1.A-5. Absolute (km²) and relative discrepancy (% relative to Government-reported data) in area of land cover classes

The smaller area of built-up area in ESA data can be explained by the fact that ESA identifies trees, grasslands, and crops within settlements. The ESA data generally features smaller patches across all land cover classes (Fig. 2.1.A-6).

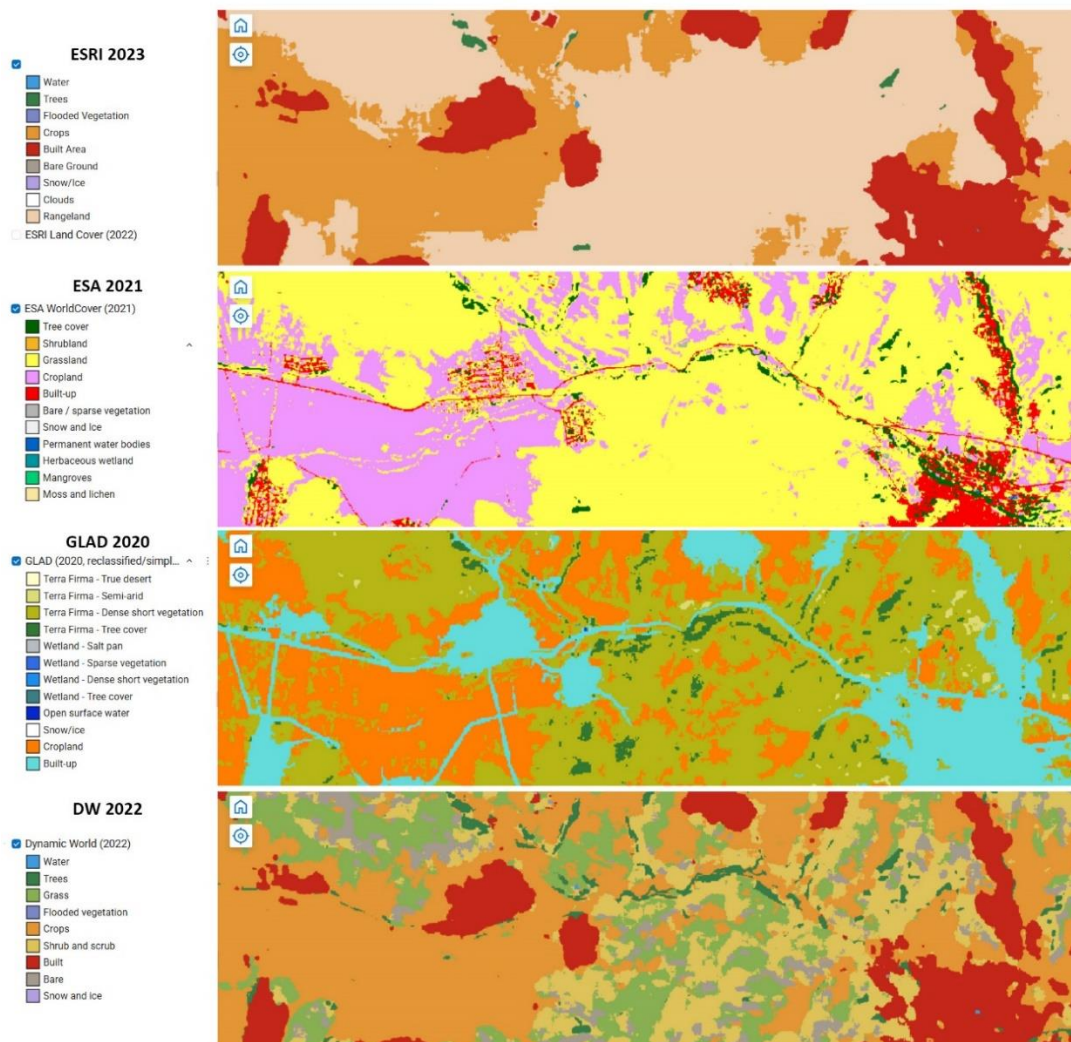

Figure 2.1.A-6. The same area as represented in different land cover datasets

The Government classification of land cover types includes, among others, shrub-covered areas. Of the four land cover datasets retained for analysis, two — ESA and DW — also include this class. However, the shrub areas identified in these datasets differ greatly from the Government-reported areas. According to ESA, shrub area is very small and consistently lower than the Government figures across all marzes. DW, on the contrary, identifies a very large shrub area — several times greater than the Government data (Table 2.1.A-1, Fig. 2.1.A-7). Thus, the presence of a “shrubs” class in these two datasets does not make them more consistent with the Government data.

Table 2.1.A-1. Area of shrub-covered areas in Government-reported data and in two land cover datasets

Marzes	GOV 2022	ESA 2021	DW 2022
Aragatsotn	3.925	0.000	361.594
Ararat	24.962	0.001	387.490
Armavir	6.341	0.001	58.548
Gegharkunik	36.351	0.000	611.396
Kotayk	23.135	0.000	372.450
Lori	48.307	0.057	345.520
Shirak	0.000	0.000	246.146
Syunik	157.423	1.042	1147.185
Tavush	29.433	8.913	310.120
Vayots Dzor	11.479	0.000	843.881

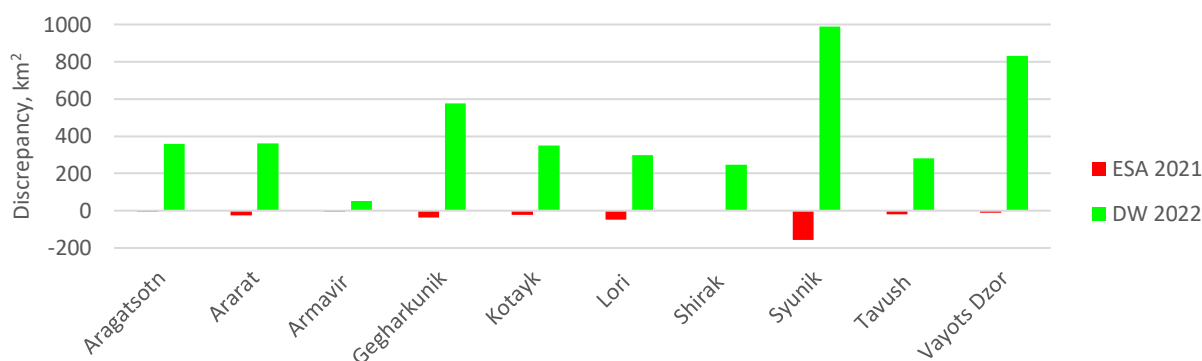

Figure 2.1.A-7. Discrepancy with Government-reported data in shrubland area.

A preliminary overall indicator for assessing land cover data accuracy can be the total discrepancy between land cover class areas in datasets and Government data. The reliability of this indicator increases when absolute errors are summed across the smallest spatial units. In this case, however, data are available only at the marz level, so the indicator we used represents the sum of absolute area discrepancies (by modulus, regardless of sign) across marzes. Overall, all four datasets show a similar total discrepancy from the Government data, ranging from 19.4% to 20.9% of Armenia’s total area. The smallest discrepancy is observed in the Esri dataset, and the largest in ESA (Fig. 2.1.A-8).

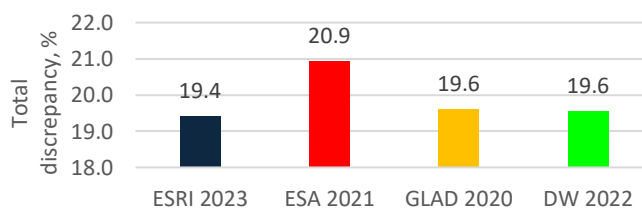

Figure 2.1.A-8. Total relative discrepancy (% relative to total area of Armenia) between tested datasets and Government-reported data

Share of land cover classes across landscape zones

Comparison of land cover class areas across landscape zones according to different datasets shows that Esri, ESA, and GLAD are generally similar to each other (Fig. 2.1.A-9). Dynamic World (DW 2022) data show a significantly larger cropland area compared to the other datasets. This is especially noticeable in highland landscapes. Croplands were identified by nearly 10% of the area of the high-altitude and alpine zones. In some mountain ranges (Gegham Range and southwestern slope of the Syuniq plateau) croplands occupy about 20% (Fig. 2.1.A-10), which is inconsistent with reality. In the subalpine zone, croplands occupy more than 10% of total.

Comparison of Esri, ESA, and GLAD datasets shows that in Esri, the cropland area is significantly larger in mountain-valley semi-desert and dry steppe zones, whereas in GLAD, the cropland area in mountain-valley semi-desert zone is smaller than in the other two datasets (Fig. 2.1.A-9). The ESA dataset is characterized by larger area of tree cover and smaller built-up area, which is particularly noticeable in the semi-deserts, dry steppe, and forest shelter belt. One of the reasons for this is that, as mentioned above, ESA identifies trees within settlements. The presence of trees in submountain semidesert zone in the ESA data is entirely due to this factor – all trees there are located inside settlements. Esri and GLAD datasets do not show any tree cover in this zone.

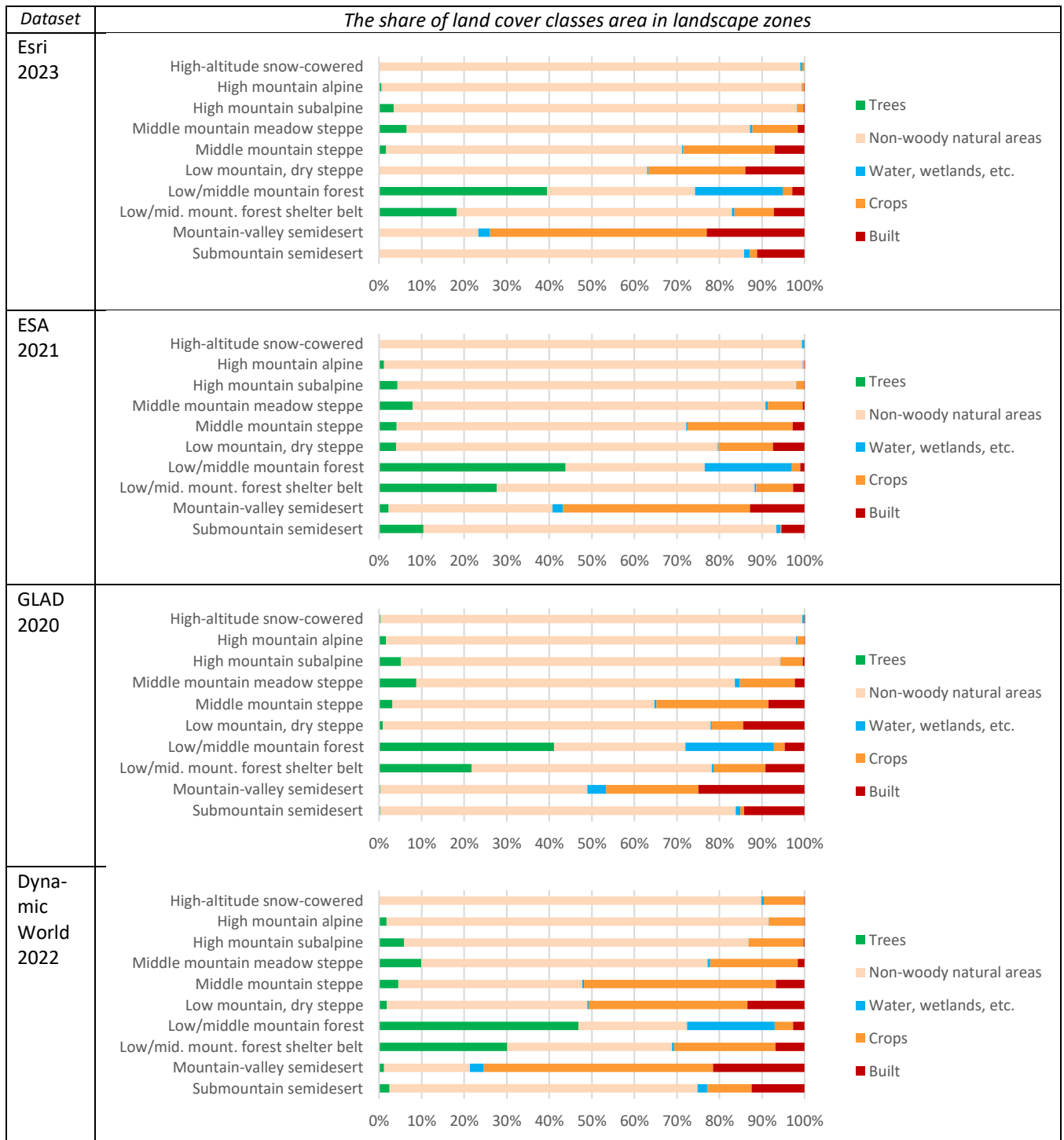

Figure 2.1.A-9. Land cover class shares across landscape zones according to tested datasets

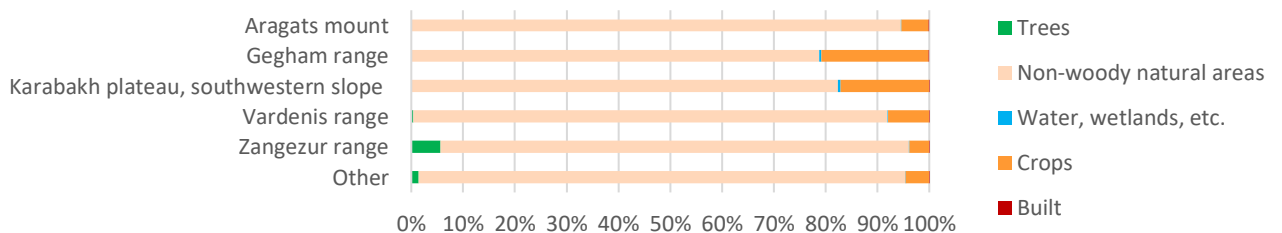

Figure 2.1.A-10. Land cover class shares in high-altitude snow-covered and high mountain alpine zones across highland systems of Armenia according DW 2022 data

2.1.B. Comparison of cropland area according to land cover datasets and Armstat data

A comparison with regional Armstat statistics on areas under cultivation¹⁰ was conducted for four land cover datasets – Esri, ESA, GLAD, and Dynamic World (GLC_FCS30D was excluded from the analysis, see Section 2.1.A). For comparison, we also used 2022 Government-reported data¹¹ on the area of cultivated land in Armenia.

Agricultural area according to landcover data was compared with three Armstat indicators for the same year as the landcover data:

- 1) Arable land, that is, an area intended for cultivation, but not necessarily used every year;
- 2) Annually cultivated area, that is the sum of annually plowed area, the area of fruit and berry plantations (including greenhouses, hothouses and inter-row fruit-bearing plantations), and vineyards;
- 3) Annually plowed area that is plantations of grains and leguminous crops, potatoes, vegetables and melons.

According to Esri, ESA, and GLAD datasets, the cropland area in most marzes is smaller than the area of arable land but larger than annually cultivated area reported by Armstat. The cropland area identified by DW exceeds the arable land reported by Armstat in almost all marzes, except for Lori and Tavush (Figure 2.1.B-1). The cultivated area reported in 2022 Government data exceed the arable land area in all marzes (GOV (A) in Fig.2.1.B-1). If the cultivated area within settlements is excluded, the difference with the Armstat data becomes smaller (GOV (B) in Fig.2.1.B-1). The cropland areas identified by all datasets exceed the annually cultivated area reported by Armstat, except for the GLAD data in Ararat and Armavir marzes. Figure 2.1.B-2 provides a more detailed breakdown by marz.

Figure 2.1.B-1. Cropland area by marz according to different data sources.

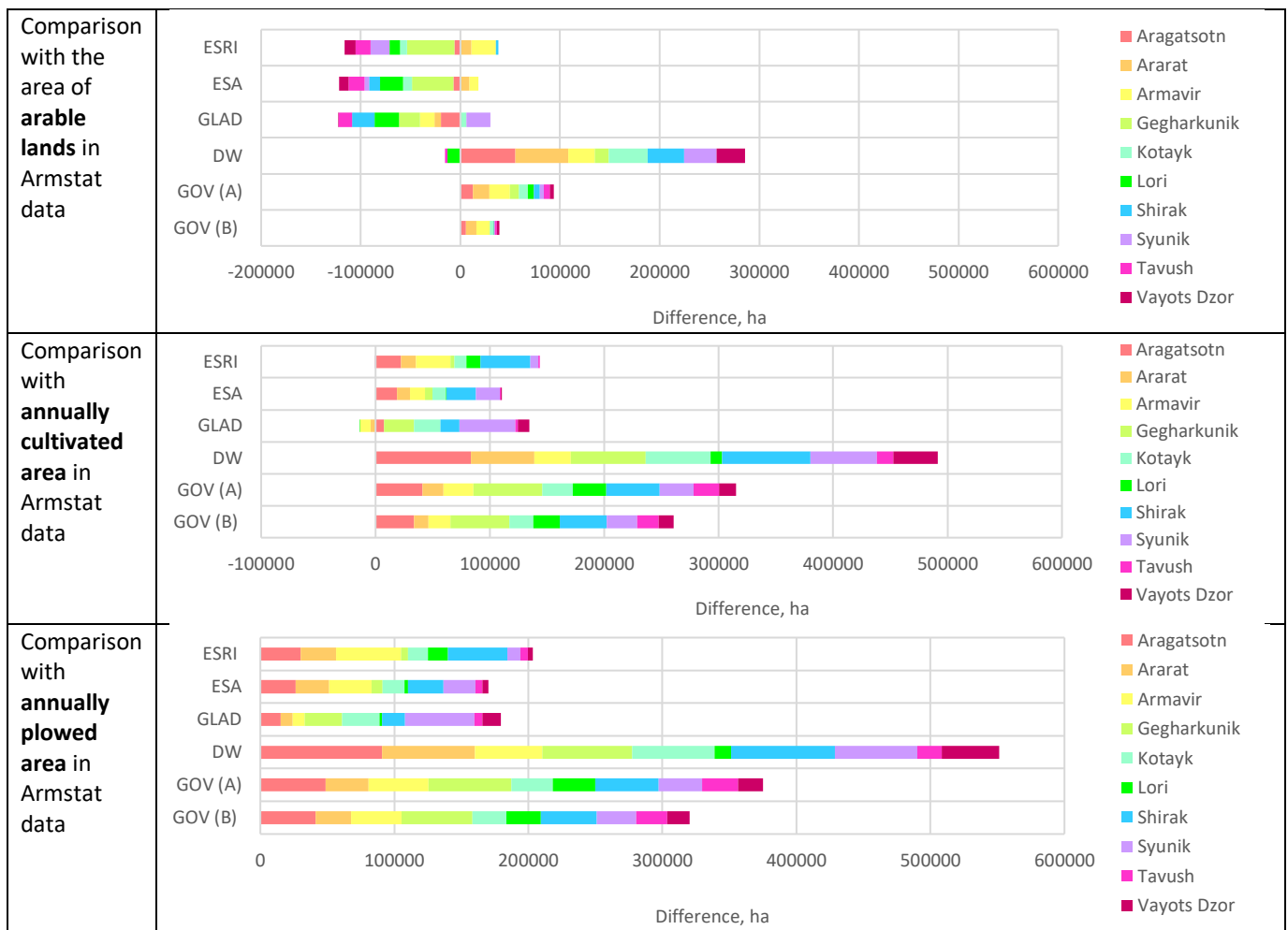

Figure 2.1.B-1. Difference between agricultural area in tested LC datasets and Armstat data on arable lands, annually cultivated, and annually plowed areas (LC data minus Armstat data)

¹⁰ <https://Armstat.am/en/?nid=651>

¹¹ <https://www.arlis.am/hy/acts/171671>

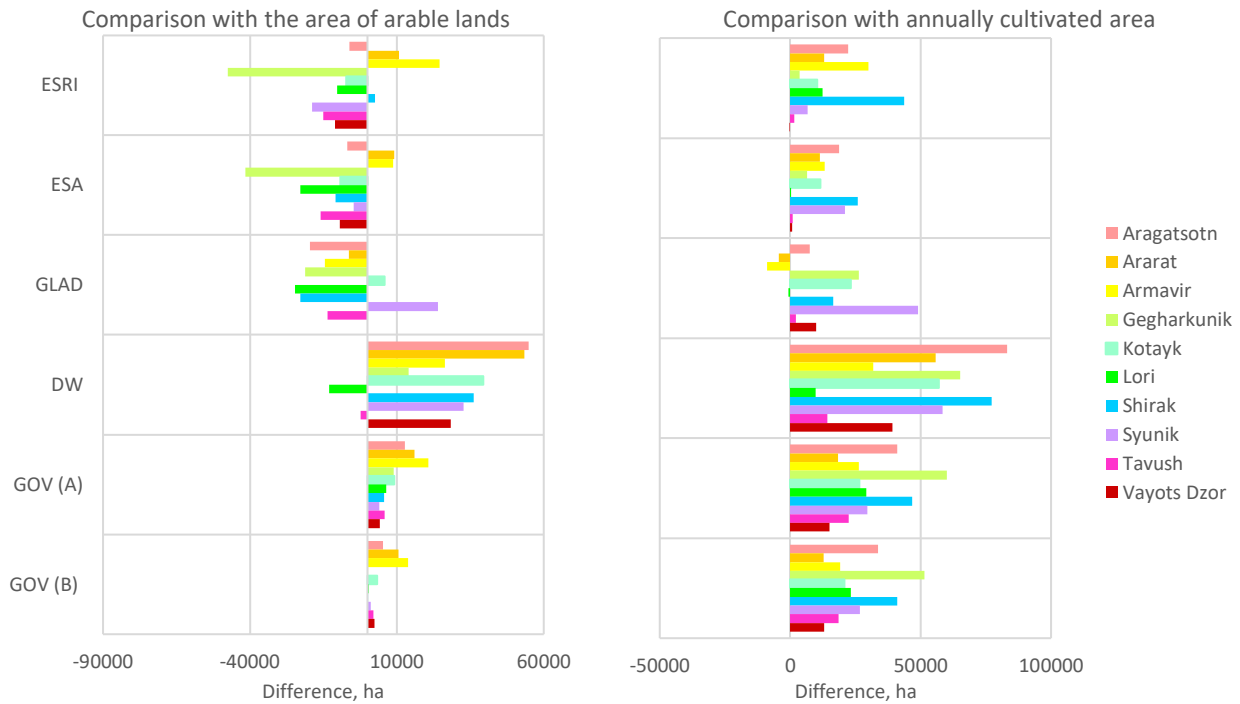

Figure 2.1.B-2. Difference between areas of croplands in tested datasets and Armstat data on arable lands, annually cultivated, and annually plowed areas (dataset data minus Armstat data) across marzes

The fact that in Esri, ESA, and GLAD datasets the cropland area is smaller than arable area but larger than annually cultivated area indicates that these datasets classify a part of arable lands which are not cultivated during the reference year as croplands. The area of land designated for cultivation that was left uncultivated in the given year is equal to $A_{stat} - C_{stat}$, where C_{stat} is cultivated area in Armstat data; A_{stat} is arable area in Armstat data. Thus, the share of uncultivated fields that are identified in Esri, ESA, and GLAD datasets as croplands can be defined as $U = (C - C_{stat}) / (A_{stat} - C_{stat})$, where C is cropland area in a dataset. Across the marzes, this figure varies between 0% and 100% (Fig. 2.1.B-3). In cases where the cropland area from land cover datasets exceeds arable land area reported by Armstat, this indicator exceeds 100%. This is most evident in the ESA and Esri data for the Ararat and Armavir marzes, where these datasets estimate the cropland area to be 20–40% larger than the arable land area reported by Armstat, while approximately 90% of the arable land in these marzes is annually cultivated. The cropland area in all datasets exceeds the annually plowed area. The Government data exceed both annually cultivated and annually plowed area reported by Armstat.

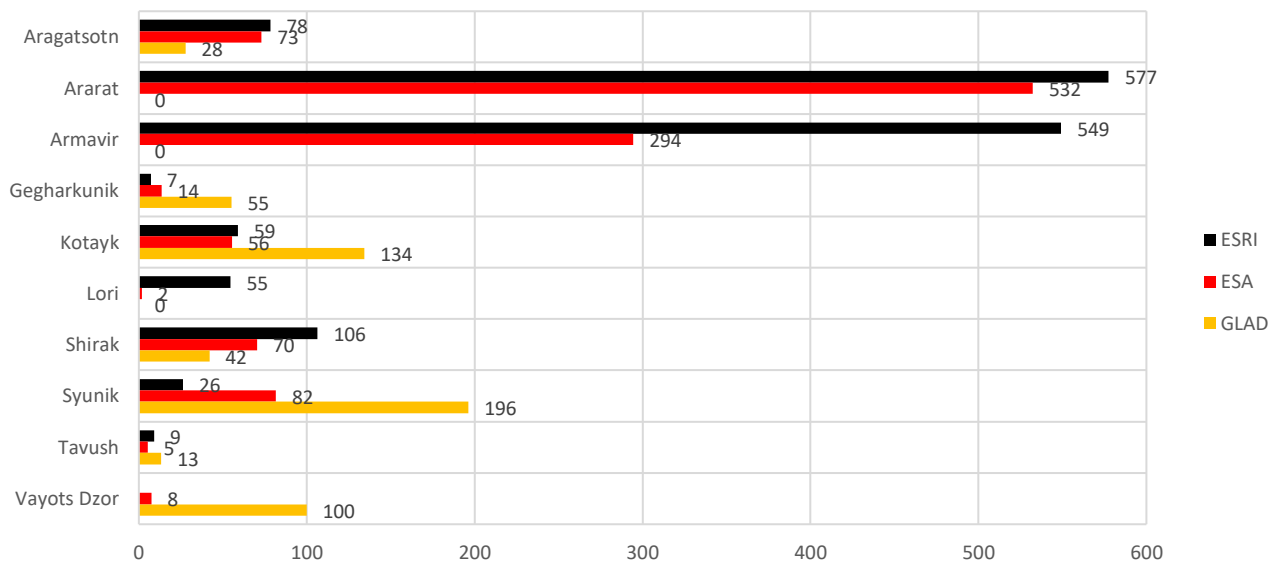

Figure 2.1.B-3. The share (%) of uncultivated arable land that is classified as cropland by the land cover datasets

Similar to the comparisons with Government-reported data (Section 2.1.A), a preliminary overall indicator for assessing land cover data accuracy can be the total discrepancy between cropland areas in datasets and Armstat data which is the sum of absolute area discrepancies (by modulus, regardless of sign) across marzes (Figure 2.1.B-4). Overall, Esri, ESA, and GLAD datasets show a similar total discrepancy from the Armstat data, DW shows a substantial overestimation of cropland area.

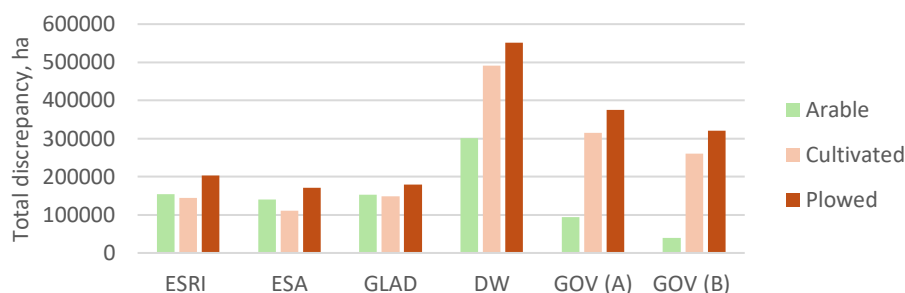

Figure 2.1.B-4. Total discrepancy between cropland areas in datasets and Armstat

2.1.C. Selection of land cover dataset for use in the project

The Esri land cover dataset was selected as the basis for the project implementation. The ESA and GLAD datasets can be additionally used for specific methodological tasks. The choice was made based on the following reasons:

- GLC_FCS30D land cover data shows very strong excess of cropland area and excess of forest area and was therefore excluded.
- Dynamic World dataset shows good agreement with the Government-reported data in indicator of total area discrepancy. However, it significantly overestimates cropland area compared to Armstat data and shows a strong excess of cropland area in the mountains. Therefore, it was excluded.
- ESA, Esri and GLAD are similar in identified areas of the generalized land cover classes and are most consistent with Armstat data on cropland area.
- Esri data provides the best opportunity for demonstrating the accounting of ecosystem indicator dynamics from 2017 and 2023.

2.2. Extent of land cover classes

2.2.A. Extent of land cover classes reported by the Government of Armenia

The Decision of the Government of the Republic of Armenia on April 11, 2019 n 431-n “On approval of the procedure for classification of the land cover of the Republic of Armenia” defined the following land cover classes for national accounting: Cultivated lands; Grasslands; Tree-covered areas; Shrub-covered areas; Water covered areas; Vegetation-free areas. Open-access annual data on the area of land-cover classes national and marz levels are available for 2020–2024¹². The data for Armenia are presented in Table 2.2.A-1 and Figure 2.2.A-1.

Table 2.2.A-1. Land cover of the Republic of Armenia (2974258.8 ha area) by classes, 2020-2024

Land cover classes	As of July 1, 2020	As of July 1, 2021	As of July 1, 2022	As of July 1, 2023	As of July 1, 2024
Cultivated lands	538361.22	538580.09	538930.12	538919.19	539620.52
Grasslands	1366386.896	1371066.28	1370749.11	1370618.62	1363686.44
Tree-covered areas	400522.06	400375.84	400279.49	382109.06	382361.15
Shrub-covered areas	34200.612	34193.77	34135.56	34124.48	34374.33
Water covered areas	151491.8	153889.698	153890.39	172088.29	172117.81
Vegetation-free areas	483295.83	476152.342	476274.17	476398.959	482098.73

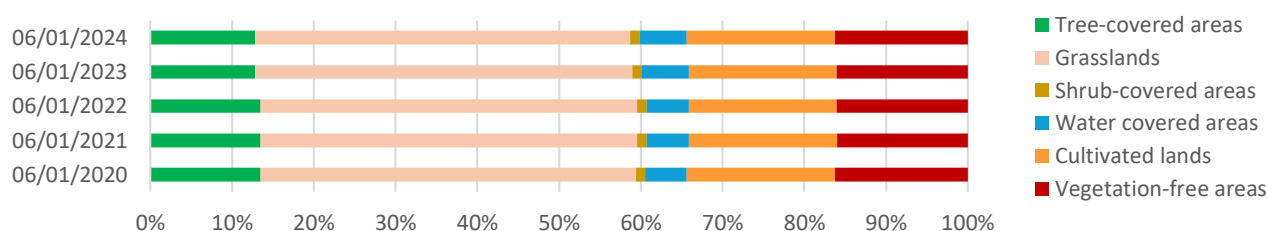

Figure 2.2.A-1. The share of land cover classes in Armenia by Government-reported data

This data is sufficient to fill in the accounting table in the SEEA EA-recommended format only partially (Table 2.2.A-2) since only data on the opening and closing extent are available (rows 1 and 9). From this data, the net change in areas is calculated (row 8). Data on gross expansion and reduction in the areas of land cover classes, which may offset each other (rows 2 and 5), as well as a breakdown of change drivers into managed and unmanaged (rows 3,4 and 6,7), are not available.

Table 2.2.A-2. Accounting table of land-cover class extent for 2020 and 2024, based on government-reported data

	Cultivated lands	Grasslands	Tree-covered areas	Shrub-covered areas	Water covered areas	Vegetation-free areas
1. Opening extent in 2020	538361.22	1366386.9	400522.06	34200.612	151491.8	483295.83
2. Additions to extent				NA		
3. Managed expansion				NA		
4. Unmanaged expansion				NA		
5. Reductions in extent				NA		
6. Managed reductions				NA		
7. Unmanaged reductions				NA		
8. Net change in extent	1259.3	-2700.46	-18160.9	173.718	20626.01	-1197.1
9. Closing extent in 2024	539620.52	1363686.44	382361.15	34374.33	172117.81	482098.73

The more detailed disaggregation of land cover classes by land fund categories provided in the Government-reported data, enables the separation of vegetation-free anthropogenic areas, i.e., built-up areas from natural ones and makes it possible to compare Governmental data and land cover datasets. The result with reclassified vegetation-free areas for Armenia and across marzes is shown in Table 2.2.A-3 and Fig.2.2.A-2.

¹² Sources:

(2021) http://www.irtek.am/DOCUMENTS/PDF/148034_havelvac.pdf; <https://faolex.fao.org/docs/pdf/arm209550.pdf>

(2022) <http://www.irtek.am/views/act.aspx?aid=156501>; <https://www.arlis.am/DocumentView.aspx?DocID=171671>

(2023) <https://www.e-draft.am/projects/6427/about>

(2024) <https://www.e-draft.am/projects/7902/about>

How to classify grasslands and cultivated lands located within settlement boundaries is a question that needs to be addressed in order to harmonize satellite-based land cover classifications with official land cover statistics. At this stage of the analysis, we kept these lands within grasslands and cultivated lands, respectively.

Table 2.2.A-3. Land cover class extent by marzes in 2022 by Government-reported data, ha

	Tree-covered areas	Grasslands	Shrub-covered areas	Vegetation-free areas	Water covered areas	Cultivated	Buil-up
Aragatsotn	8571.9	163313.3	392.5	20565.3	2189.9	67143.7	15095.6
Ararat	12724.74	99272.39	2496.22	35572.84	7090.2	40224.09	11061.98
Armavir	582.41	29283.57	634.13	17666.4	3010.438	60572.6	11345.59
Gegharkunik	21889.88	238054.4	3635.07	39933.93	124010.7	90318.54	17289.28
Kotayk	20810.43	102757.6	2313.48	20405.93	1661.12	45813.84	13820.73
Lori	86365.8	200387.6	4830.7	23510.69	4751.58	48300.81	11717.3
Shirak	4598.8	144403.9	0	13622.23	3427.13	83846.24	18128.89
Syunik	80905.01	194761.5	15742.25	91253.96	5576.07	47958	14345
Tavush	133659.9	82690.46	2943.31	10681.01	1094.24	31359.26	7970.77
Vayots Dzor	28325.5	114823.3	1147.9	60825.9	923.4	20109.42	4857.7
Yerevan	1845.1	1001.2	0	1133.29	155.61	3283.62	14909.08
Armenia	400279.5	1370749	34135.56	335171.5	153890.4	538930.1	140541.9

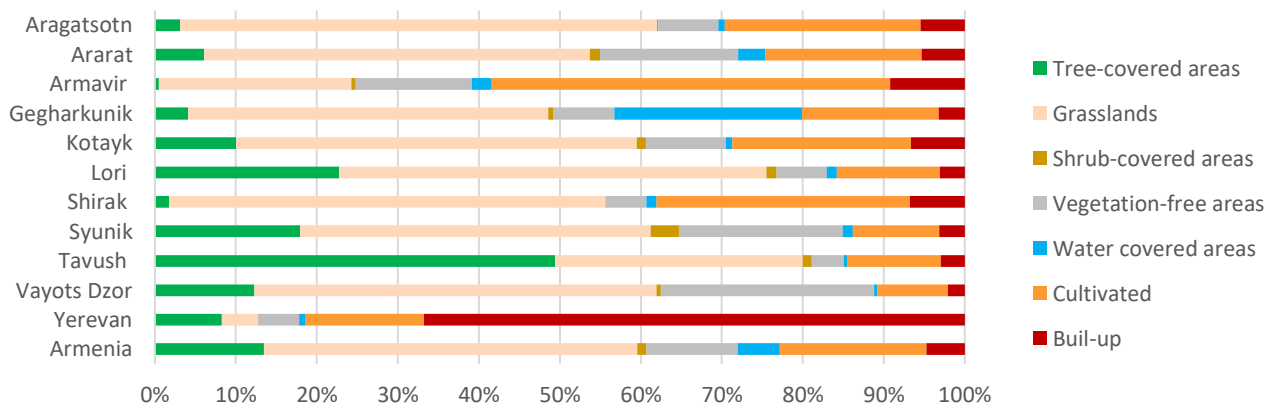

Figure 2.2.A-2. The share of land cover classes in Armenia and across marzes by the Government-reported data

2.2.B. Extent of land cover classes by Esri data

Since the Esri land cover dataset was selected for use in the project (Section 2.1.A), the subsequent extent assessment was conducted by Esri data based on the area of 1 pixel equal to 100 m². The extent of different land cover classes according to the other datasets can be found in the Section 2.1.A. The area of Lake Sevan and the administrative area of Yerevan were excluded from the extent assessment.

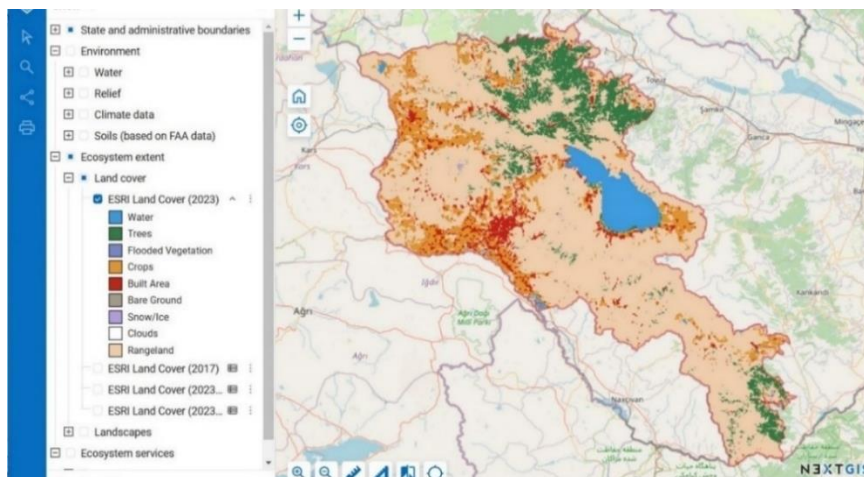

Figure 2.2.B-1. Esri dataset for Armenia. For detailed maps see project Web GIS <https://bccarmenia.nextgis.com/>), section "Ecosystem extent - Landcover"

Extent of land cover classes at the national, marz, and watershed levels

Most of the Armenia’s territory is covered by grasslands (68% according to Esri data), forests occupy 11% (13% according to Government data), croplands and built-up areas account for 12% and 5%, respectively. The most human-transformed marz is Armavir, where croplands and built-up areas together make up over 60% of the territory. The least transformed marzes are Vayots Dzor, Tavush, and Syunik. Forests cover the largest area in Tavush (around 50%), and are also widespread in Lori, where they exceed 20% of the territory (Tables 2.2.B-1 and 2.2.B-2; Figures 2.2.B-2 and 2.2.B-3).

Table 2.2.B-1. The extent of land cover classes in 2017, km²

	Rangeland	Trees	Bare ground	Snow/Ice	Flooded veget.	Water	Crops	Built Area	Total
Aragatsotn	2,161.08	52.54	12.60	0.02	0.00	3.43	380.13	126.33	2,736.12
Ararat	1,522.66	30.47	16.35	0.01	11.71	29.16	359.92	144.64	2,114.91
Armavir	455.53	2.84	5.45	0.00	1.81	6.67	645.14	146.25	1,263.70
Gegharkunik	3,320.37	134.93	19.08	0.04	1.40	1,274.09	315.10	182.98	5,248.00
Kotayk	1,506.57	171.74	7.47	0.74	0.01	2.49	270.63	155.14	2,114.80
Lori	2,558.39	869.51	4.55	0.02	0.44	2.64	189.21	138.24	3,763.00
Shirak	1,998.79	13.08	4.31	0.00	0.07	27.21	537.55	137.61	2,718.63
Syunik	3,571.06	634.26	33.14	0.13	0.04	17.98	170.64	66.09	4,493.35
Tavush	1,234.28	1,304.10	1.34	0.00	0.00	4.00	91.52	91.00	2,726.24
Vayots Dzor	2,157.65	47.10	14.01	0.02	0.01	2.76	35.26	39.74	2,296.54
Armenia	20,549.27	3,261.03	119.68	0.97	15.47	1,371.25	3,018.23	1,372.59	29,708.49

Table 2.2.B-2. The extent of land cover classes in 2023, km²

	Rangeland	Trees	Bare ground	Snow/Ice	Flooded veget.	Water	Crops	Built Area	Total
Aragatsotn	2,096.86	48.25	3.48	6.38	0.00	3.50	438.49	139.17	2,736.12
Ararat	1,560.01	26.20	6.94	0.04	6.74	32.42	305.46	177.10	2,114.91
Armavir	461.83	0.55	2.05	0.00	0.15	7.10	609.26	182.76	1,263.70
Gegharkunik	3,239.85	129.56	4.28	0.94	0.65	1,274.08	404.99	193.66	5,248.00
Kotayk	1,508.64	153.10	1.08	1.60	0.00	2.57	265.38	182.43	2,114.80
Lori	2,424.92	883.74	2.83	0.31	0.79	3.81	298.87	147.73	3,763.00
Shirak	1,784.67	13.43	0.91	2.47	0.00	31.48	742.89	142.79	2,718.63
Syunik	3,650.25	507.74	12.65	0.09	0.02	15.86	233.22	73.53	4,493.35
Tavush	1,227.75	1,316.33	0.05	0.04	0.02	4.35	82.03	95.67	2,726.24
Vayots Dzor	2,174.55	38.13	2.51	0.35	0.00	2.35	33.28	45.37	2,296.54
Armenia	20,185.02	3,117.51	37.33	12.21	8.39	1,378.29	3,422.08	1,547.66	29,708.49

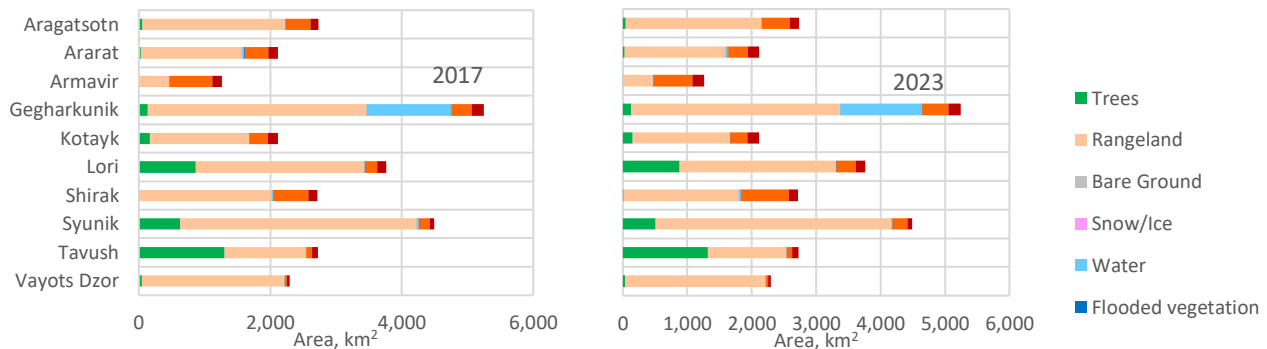

Figure 2.2.B-2. Area of land cover classes in 2017 and 2023, km²

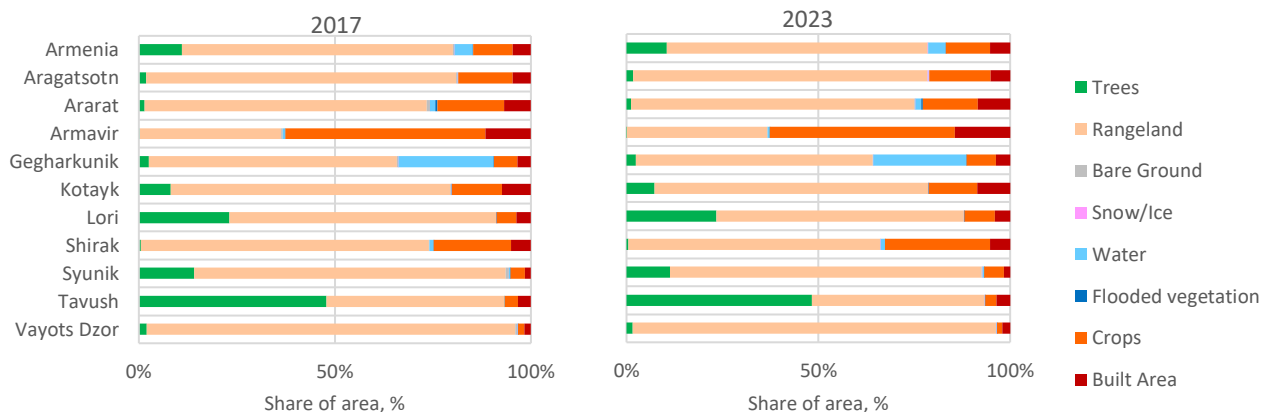

Figure 2.2.B-3. The share of land cover classes in 2017 and 2023, %

Land cover class extent accounting was also carried out for the large watersheds, since one of the key purposes of ecosystem accounting is to assess water-regulating ecosystem services, which are modeled at the watershed level. Since in Armenia watershed boundaries largely coincide with marz boundaries (the Hrazdan, Metsamor, and Arpa watersheds each include two marzes), the pattern of land cover class area distribution and its changes from 2017 to 2023 mirrors the pattern identified at the marz level.

The most human-transformed watersheds are Metsamor (marzes Aragatsotn and Armavir) and Akhuryan (marz Shirak), where croplands and built-up areas together make up around 30% of the territory. The least transformed watersheds are Aghstev (marz Tavush) and Vorotan (marz Syunik). Forests cover large areas in Aghstev watershed (marz Tavush) and Debed watershed (Lori marz) (Tables 2.2.B-6 and 2.2.B-7; Figures 2.2.B-5 and 2.2.B-6).

Table 2.2.B-6. Area of land cover classes in watersheds in 2017, km²

	Trees	Rangeland	Bare Ground	Snow/Ice	Flooded vegetation	Water	Crops	Built Area
Aghstev	1401.27	1600.07	1.99	0.01	0.00	3.70	69.63	98.72
Akhuryan	9.30	1999.78	4.42	0.00	0.07	27.25	599.85	144.59
Arpa	79.92	3839.27	30.63	0.15	10.84	26.36	288.32	134.83
Debed	843.51	2719.90	4.83	0.02	0.44	3.11	212.89	141.05
Hrazdan	243.39	4384.18	27.42	0.65	1.68	1281.05	765.19	545.57
Metsamor	49.32	2420.53	17.31	0.02	2.41	11.80	911.62	241.75
Vorotan	634.26	3573.45	32.93	0.13	0.04	17.98	170.65	66.09

Table 2.2.B-7. Area of land cover classes in watersheds in 2023, km²

	Trees	Rangeland	Bare Ground	Snow/Ice	Flooded vegetation	Water	Crops	Built Area
Aghstev	1397.07	1590.30	0.09	0.08	0.02	4.04	80.02	103.76
Akhuryan	9.54	1801.94	0.90	2.36	0.00	31.54	789.01	149.95
Arpa	66.30	3890.99	9.26	0.73	6.22	29.55	249.59	157.67
Debed	865.33	2575.47	2.84	0.27	0.79	4.29	325.58	151.17
Hrazdan	228.70	4305.51	6.24	2.17	0.67	1280.73	794.73	630.37
Metsamor	42.74	2356.44	5.25	6.48	0.66	12.27	949.72	281.20
Vorotan	507.74	3652.35	12.65	0.11	0.02	15.86	233.26	73.54

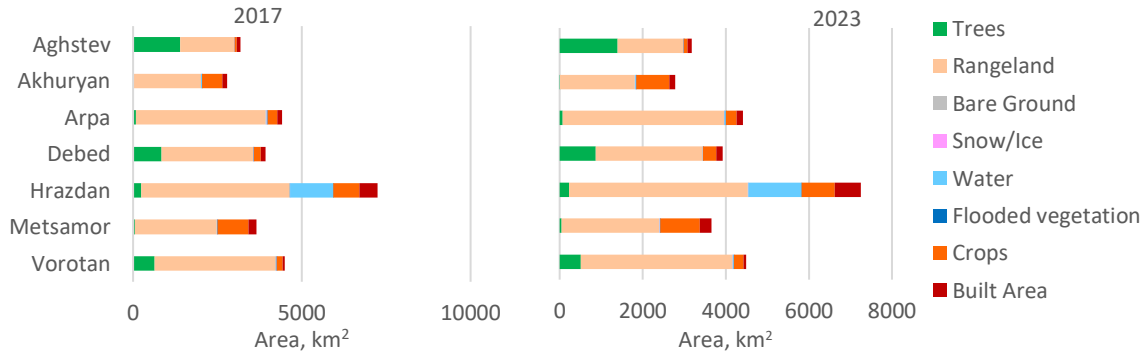

Figure 2.2.B-5. Area of land cover classes across watersheds in 2017 and 2023, km²

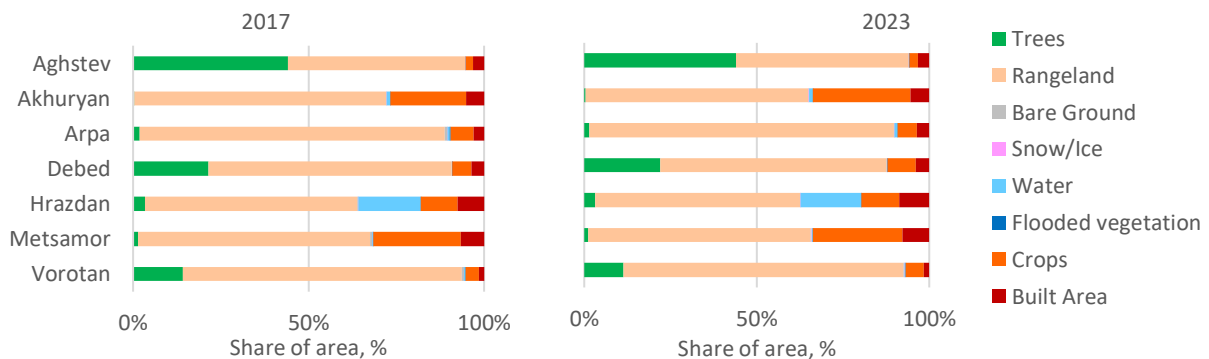

Figure 2.2.B-6. The share of land cover classes across watersheds in 2017 and 2023, %

Changes in land cover class extent

Between 2017 and 2023, according to Esri data, the area of croplands and built-up areas in Armenia increased by 417 km² and 175 km², respectively, while the area of forests and grasslands decreased by 139 km² and 383 km² (Figure 2.2.B-4; Table 2.2.B-3). The total area of natural land-cover types decreased by 578.9 km² (1.95% of the country’s total area) over these years, transitioning to croplands and built-up areas.

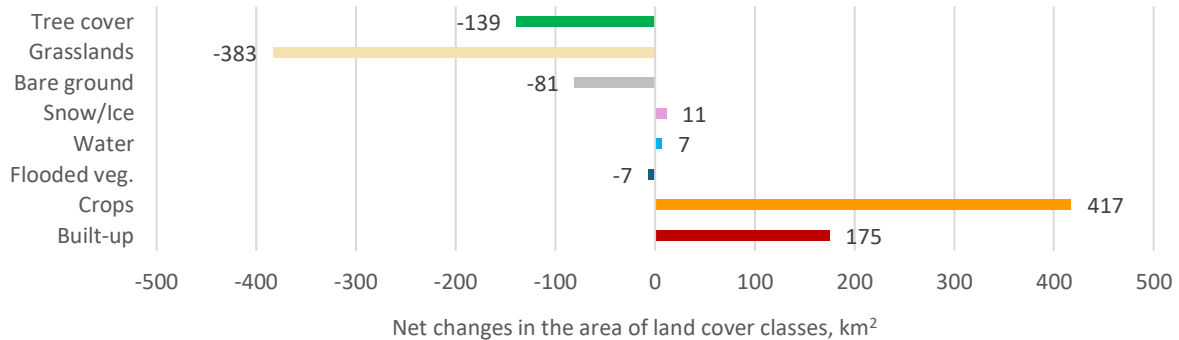

Figure 2.2.B-4. Changes in the area of land cover classes from 2017 to 2023

The map of changes in land cover (Figure 2.2.B-5) shows that built-up areas expanded primarily in the Ararat Valley and around Yerevan (maroon color), while croplands expanded most intensively in the north-western part of the country (orange color in Fig 2.2.B-5). Local forest expansion occurred in several locations within Armenia’s forest zone in the north-east; however, overall forest extent decreased, mainly due to transitions to grasslands in Syunik. Grasslands expanded in the southern part of Syunik marz, but their total extent across Armenia also decreased due to transitions to croplands.

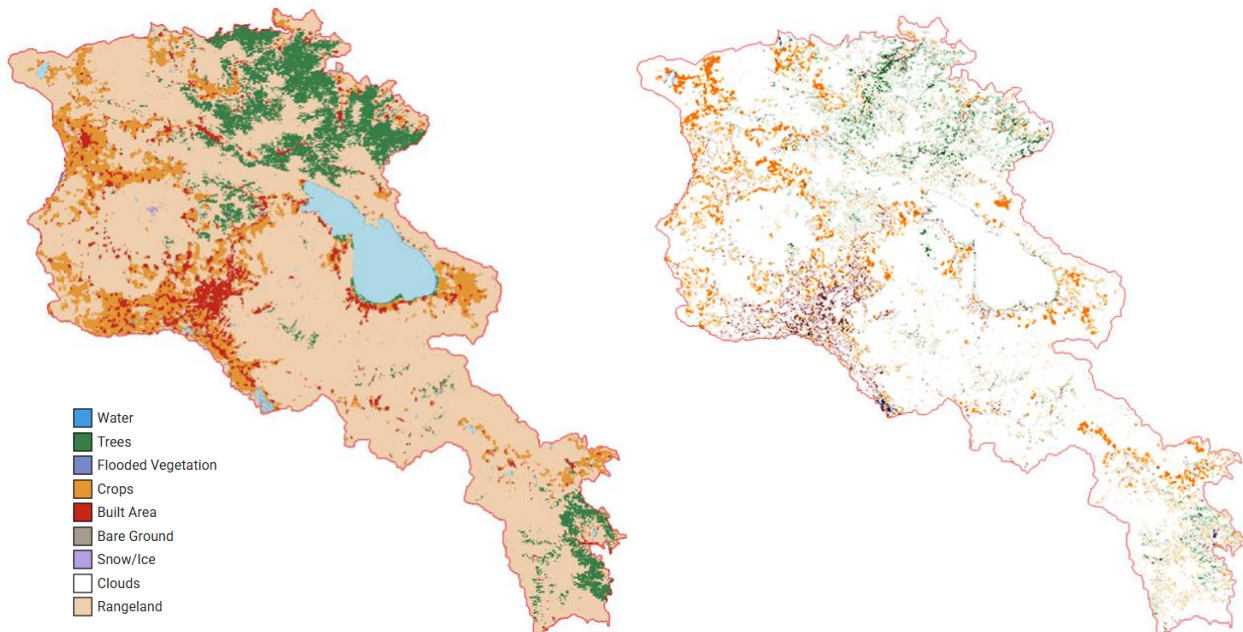

Figure 2.2.B-5. The land cover and its changes: a) Esri land cover data for 2023; b) The land-cover changes that occurred since 2017, specifically the new land-cover classes that emerged in place of previous ones, are shown.

The land-cover class transition matrix shows how much area of each class transitioned to another class (Table 2.2.B-3). In this matrix, the classes listed in the first column transform into the classes shown across each row. Example: In the *tree cover* row, the area that remained tree cover is 2909.87 km² (tree cover transitioned to tree cover), tree cover transitioned to grasslands over an area of 362.79 km², to bare ground - 0.02 km², and so on. The most intensive transition was from grasslands to croplands (941 km²), while reverse transition is less than half of that value (444 km²). The shift from tree cover to grasslands is also noticeable (362 km²). Other transitions are negligible (Fig. 2.2.B-6).

The sum of transitions to other classes corresponds to the loss of tree cover due to these conversions (last column, 369.92 km²). At the same time, other classes transitioned into tree cover, producing its gain of 230.88 km² (bottom row).

Thus, the net change in tree cover is negative and equals to 139.04 km². The data make it possible to populate rows “Additions to extent” and “Reductions in extent” in the accounting table of land cover class extent (Table 2.2.B-4), which are unknown if we know only the opening and closing extent. As noted in Section 1.4.A, we do not have data to distinguish between managed and unmanaged land cover changes.

Table 2.2.B-3. Land cover class transition matrix from 2017 to 2023, km²

	Tree cover	Grasslands	Bare ground	Snow/Ice	Water	Flooded veg.	Crops	Built-up	Total area in 2017	Reduction
Tree cover →	2909.87	362.79	0.02	0.05	0.58	0.02	3.74	2.72	3279.79	369.92
Grasslands →	224.03	19221.76	2.12	7.56	13.46	1.74	940.92	114.62	20526.21	1304.45
Bare ground →	0.05	75.63	29.67	3.70	1.97	0.24	2.10	2.59	115.94	86.27
Snow/Ice →	0.01	0.49	0.04	0.33	0.01	0.00	0.02	0.06	0.96	0.63
Water →	0.44	8.74	2.29	0.04	101.20	0.47	7.41	1.53	122.12	20.92
Flooded veg. →	0.05	3.34	0.05	0.00	4.48	4.78	1.81	0.87	15.37	10.59
Crops →	3.04	444.42	0.42	0.29	6.62	1.18	2478.53	97.21	3031.70	553.17
Built-up →	3.27	25.79	0.76	0.03	0.50	0.02	14.40	1335.95	1380.72	44.77
Total area in 2023	3140.75	20142.95	35.35	12.00	128.82	8.46	3448.92	1555.56	28472.82	
Expansion	230.88	921.19	5.69	11.67	27.62	3.68	970.39	219.61		2390.73

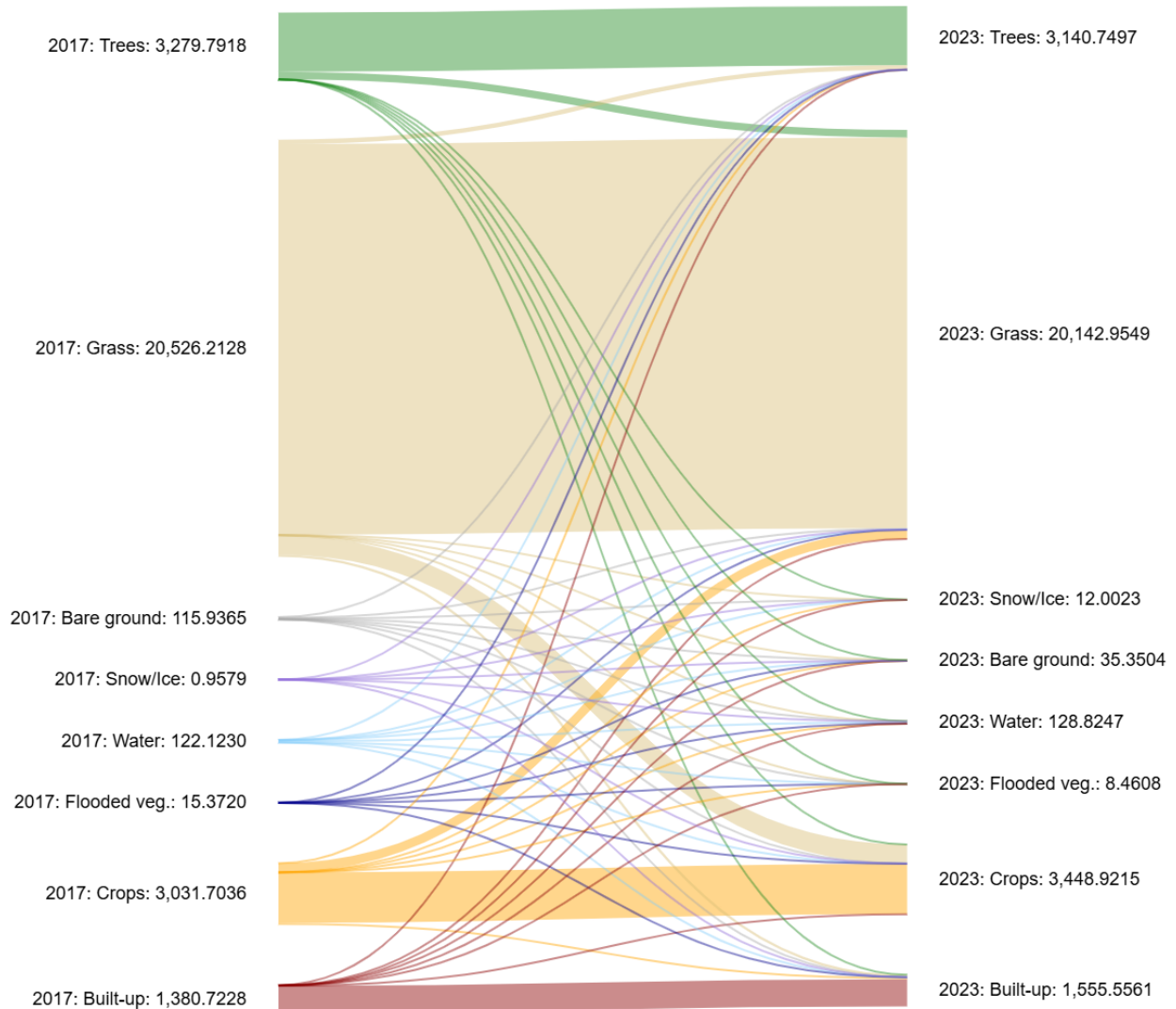

Figure 2.2.B-6. Transitions between land cover classes from 2017 to 2023

Table 2.2.B-4. Accounting table of extents for land-cover classes in 2017 and 2023, based on Esri land cover dataset

	Trees	Grass	Bare ground	Snow/Ice	Water	Flooded veg.	Crops	Built-up
1. Opening extent in 2020	3279.79	20526.21	115.94	0.96	122.12	15.37	3031.70	1380.72
2. Additions to extent	230.88	921.19	5.69	11.67	27.62	3.68	970.39	219.61
3. Managed expansion	NA							
4. Unmanaged expansion	NA							
5. Reductions in extent	369.92	1304.45	86.27	0.63	20.92	10.59	553.17	44.77
6. Managed reductions	NA							
7. Unmanaged reductions	NA							
8. Net change in extent	-139.04	-383.26	-80.59	11.04	6.70	-6.91	417.22	174.83
9. Closing extent in 2024	3140.75	20142.95	35.35	12.00	128.82	8.46	3448.92	1555.56

The most significant changes occurred in Shirak marz, where cropland area increased by 200 km² at the expense of grasslands. Similar but less extensive cropland expansion at the expense of grasslands took place in Lori, Gegharkunik, and Aragatsotn. In contrast, in Armavir and Ararat, cropland area decreased. In Armavir, this was due to an increase in built-up areas, while in Ararat, it resulted from both an expansion of built-up areas and grasslands. In Syunik marz, forest area noticeably declined due to an increase in grasslands and croplands (Table 2.2.B-5; Figure 2.2.B-7a). Relative changes in land cover areas exhibit a somewhat different picture. In 2023, the Esri land cover dataset shows an 80% loss of tree cover in Armavir marz compared to 2017, although this loss is barely noticeable in absolute terms due to the initially small woody area in that marz. The largest relative increase in cropland area was identified in Lori marz — nearly 60% (Figure 2.2.B-7b).

Table 2.2.B-5. Changes across the area of land cover classes from 2017 to 2023, km²

	Rangeland	Trees	Bare Ground	Snow/Ice	Flooded vegetation	Water	Crops	Built Area
Aragatsotn	-64.22	-4.29	-9.12	6.36	0.00	0.06	58.36	12.84
Ararat	37.35	-4.28	-9.42	0.04	-4.96	3.27	-54.46	32.46
Armavir	6.30	-2.29	-3.41	0.00	-1.65	0.43	-35.88	36.50
Gegharkunik	-80.52	-5.37	-14.81	0.90	-0.75	-0.02	89.89	10.68
Kotayk	2.07	-18.64	-6.39	0.86	-0.01	0.08	-5.26	27.28
Lori	-133.47	14.22	-1.72	0.28	0.35	1.17	109.66	9.50
Shirak	-214.12	0.34	-3.40	2.47	-0.06	4.26	205.33	5.18
Syunik	79.18	-126.52	-20.49	-0.04	-0.02	-2.12	62.58	7.44
Tavush	-6.54	12.23	-1.28	0.04	0.02	0.35	-9.49	4.68
Vayots Dzor	16.90	-8.97	-11.50	0.33	-0.01	-0.41	-1.98	5.63
Armenia	-364.25	-143.52	-82.35	11.23	-7.08	7.04	403.85	175.08

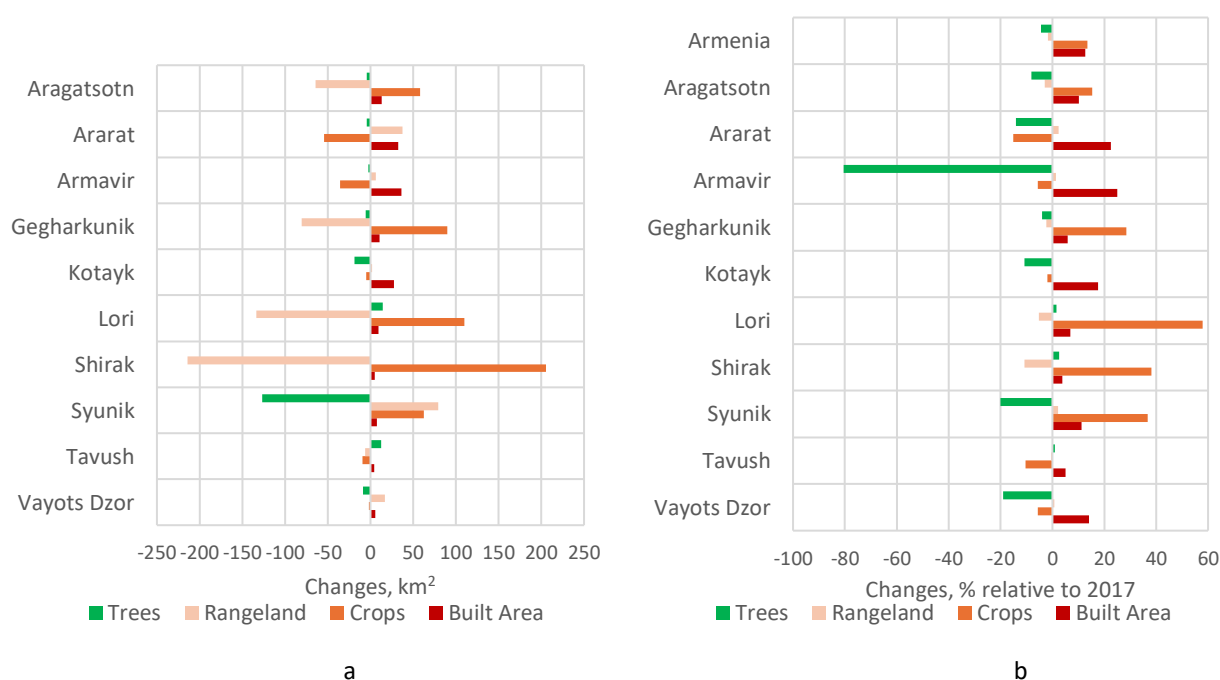

Figure 2.2.B-7. Absolute (km²) and relative (% of 2017 area) changes in the area of the main land cover classes in Armenia and across marzes from 2017 to 2023

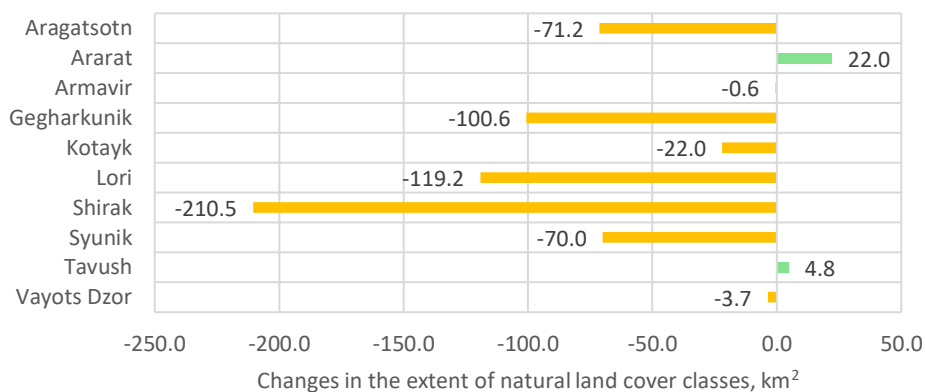

Figure 2.2.B-8. Total changes in the extent of natural land cover classes across marzes from 2017 to 2023

Across watersheds, the most significant changes in land cover area occurred in Akhurian watershed (Shirak marz), where cropland area increased by 200 km² at the expense of grasslands. Similar but less extensive cropland expansion at the expense of grasslands took place in Debed watershed (Lori marz). In the Hrazdan and Metsamor watersheds, grassland areas decreased due to the expansion of croplands and built-up areas. Changes in the Arpa watershed are driven by changes in Ararat marz, where cropland area decreased due to the expansion of built-up areas and grasslands. In Vorotan watershed (Syunik marz), forest area noticeably declined due to an increase in grasslands and croplands (Table 2.2.B-8; Figure 2.2.B-9a).

Relative changes show the largest relative increase in cropland area in Debed watershed (Lori marz) and significant increase in cropland area in Vorotan watershed (Syunik marz) and Akhurian watershed (Shirak marz). In the Vorotan, Arpa, and Metsamor watersheds, forest area decreased by 10–20% (Figure 2.2.B-9b).

Table 2.2.B-8. The changes in area of land cover classes from 2017 to 2023, km²

	Trees	Rangeland	Bare Ground	Snow/Ice	Flooded vegetation	Water	Crops	Built Area
Aghstev	-4.20	-9.77	-1.90	0.08	0.02	0.34	10.39	5.04
Akhurian	0.25	-197.84	-3.52	2.36	-0.06	4.29	189.17	5.35
Arpa	-13.62	51.72	-21.36	0.58	-4.62	3.19	-38.73	22.85
Debed	21.82	-144.43	-1.99	0.25	0.35	1.18	112.69	10.12
Hrazdan	-14.69	-78.67	-21.18	1.52	-1.01	-0.32	29.54	84.81
Metsamor	-6.59	-64.09	-12.06	6.46	-1.75	0.47	38.10	39.46
Vorotan	-126.52	78.89	-20.28	-0.02	-0.02	-2.12	62.62	7.45

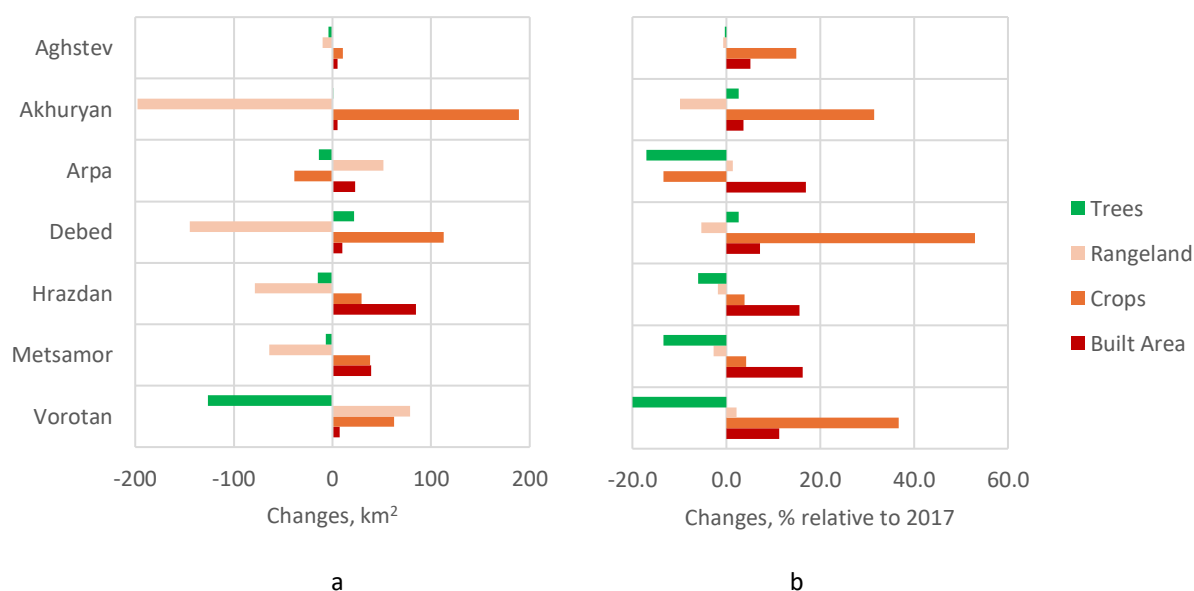

Figure 2.2.B-9. Absolute (km²) and relative (% of 2017 area) changes in area of the main land cover classes across watersheds from 2017 to 2023

2.3. Extent of ecosystems (vegetation types)

2.3.A. Ecosystem extent at national and marz levels

Vegetation types most accurately reflect the characteristics of terrestrial ecosystems, because vegetation reflects all the main habitat conditions (climate, soil, topography) and forms the trophic basis of ecosystems and largely determines both their functioning and their species diversity. The assessment of the extent of ecosystem types was made based on a vegetation map created by the project experts Alla Aleksanyan and Vardan Asatryan (Fig. 2.3.A-1a). The map was created based on Barseghyan (2007) and other materials.

The current natural area of vegetation zones is defined as the potential area of a given vegetation type minus cropland and built-up areas based on Esri land cover data 2023 (Fig. 23A-1b). The current distribution of forests is also derived from Esri land-cover data (Fig. 2.3.A-1c). At this scoping stage, all forests are treated as a single type, regardless of the vegetation zone in which they occur. In the future, when producing a detailed terrestrial ecosystem map, forests should also be classified by type.

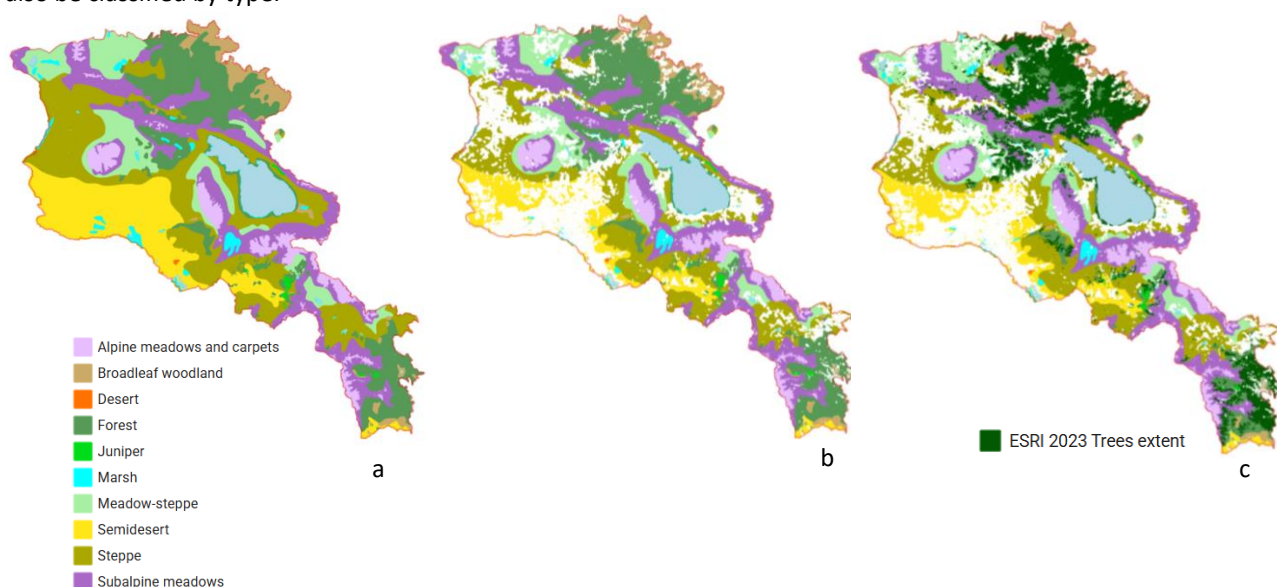

Figure 2.3.A-1. Maps of vegetation: a) potential distribution of vegetation types; b) current natural area of vegetation zones; c) ecosystem types, including current tree cover. For detailed map see project Web GIS (<https://bccarmenia.nextgis.com/>), sections Ecosystem Extent/Vegetation/Vegetation map 2025

According to Esri data, the most human-transformed vegetation zone is semi-desert, where only 56% of natural areas have remained as it is. It is followed by marshes and steppes with 70% and 76% of natural areas remaining, respectively. Tree cover occupies more than 40% of the forest zone and more than 20% of the broadleaf woodland zone. Significant forest patches are also present in subalpine meadows, meadow-steppe, and steppe zones. In the remaining zones, the tree cover identified by Esri occupies a very small area — from 0 to 4 km². In the marsh zone, water bodies occupy a substantial area (Lake Sevan is excluded from the analysis) (Table 2.3.A-1; Figure 2.3.A-2).

Table 2.3.A-1. Current area of land cover classes across vegetation zones, km²

	Grass-lands	Tree cover	Bare gr-d	Snow/Ice	Flood. veg.	Water	Crops	Built-up	Total	Share of natural classes, %
Alpine	1625.72	0.63	10.21	11.70	0.03	1.93	3.32	0.80	1654.34	99.75
Subalpine	4287.98	256.92	5.28	0.26	0.09	2.85	85.56	25.20	4664.14	97.63
Meadow-steppe	2587.14	77.83	0.22	0.04	0.76	6.66	460.94	93.06	3226.64	82.83
Steppe	5229.35	95.86	3.24	0.00	0.03	4.89	1317.52	403.45	7054.33	75.60
Forest zone	2892.93	2431.91	3.91	0.00	0.60	30.37	155.70	199.61	5715.04	93.78
Broadleaf woodl.	695.02	269.12	2.64	0.00	0.01	7.29	125.86	83.92	1183.86	82.28
Juniper	129.59	4.20	0.00	0.00	0.16	0.08	0.87	0.12	135.02	99.27
Semidesert	2459.00	3.44	8.62	0.00	2.90	29.21	1212.83	716.50	4432.49	56.47
Desert	6.64	0.00	0.21	0.00	0.00	0.00	0.52	0.28	7.65	89.58
Marsh	229.59	0.84	1.00	0.00	3.89	45.54	85.81	32.63	399.30	70.34
Total in Armenia	20142.95	3140.75	35.35	12.00	8.46	128.82	3448.92	1555.56	28472.82	82.42

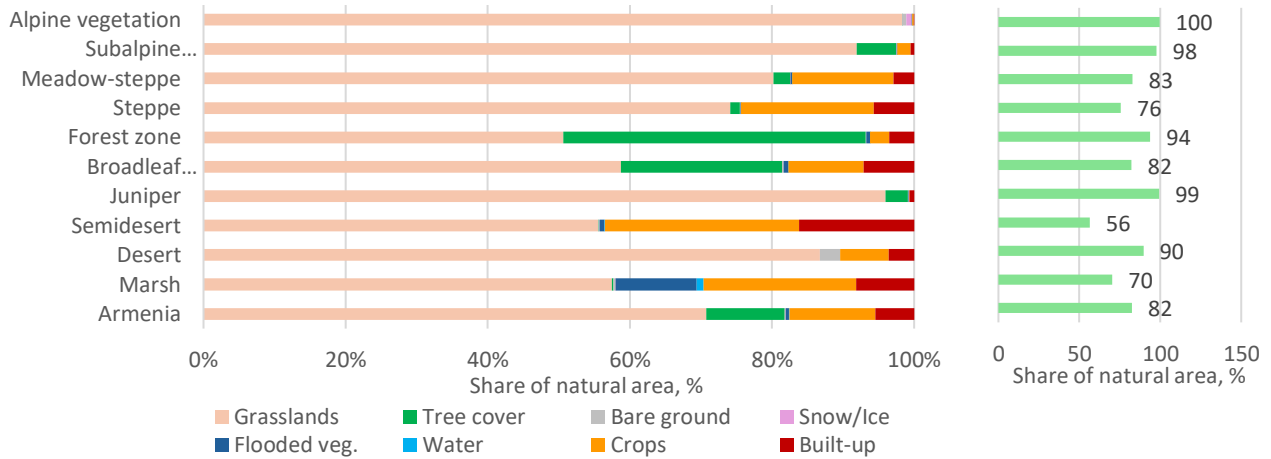

Figure 2.3.A-2. Share of land cover classes across vegetation zones, %

Considering all tree-covered areas as forest, the most widespread natural areas are in steppe and subalpine zones (exceeding 5,000 km² and 4,000 km² respectively), followed by forests and grasslands in forest zone each covering approximately 3,000 km². The smallest zones are marshes and juniper woodlands (270 and 130 km², respectively), as well as the extreme small desert zone, which consists of a single patch covering only 7 km² (Figure 2.3.A-3).

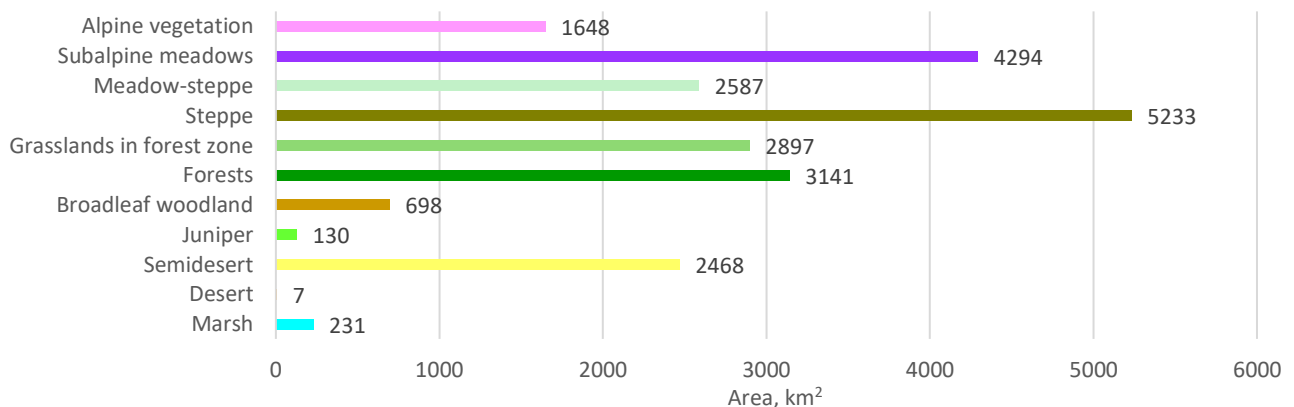

Figure 2.3.A-3. Area of natural ecosystem types, km²

The ecosystem extent (i.e., the area not occupied by croplands or built-up areas) is the greatest in Syunik marz and the smallest in Armavir marz (Table 2.3.A-2; Figure 2.3.A-4). Forests and grasslands in forest zone occupy the largest areas in the Lori, Syunik, and Tavush marzes. Alpine and subalpine ecosystems are most extensive in Syunik and Gegharkunik marzes. Steppe and meadow-steppe occupy substantial areas across all marzes except Armavir and Tavush, with the greatest extents in Gegharkunik and Shirak. The largest areas of natural semidesert have been preserved in the marzes of Aragatsotn, Armavir, and Ararat.

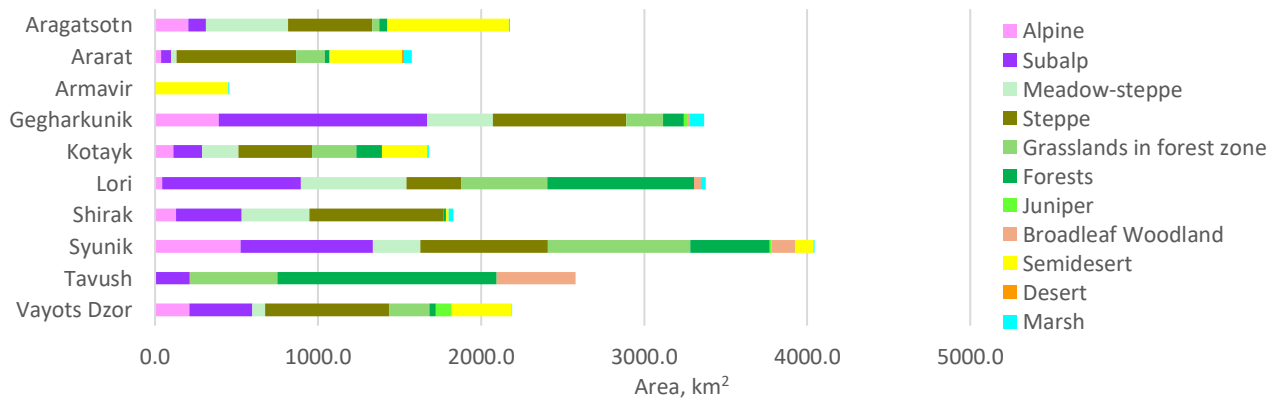

Figure 2.3.A-4. Extent of natural vegetation types across marzes in 2023

Table 2.3.A-2. Extent of natural ecosystems, anthropogenic land cover classes, and water (excluding Sevan Lake) by marzes in 2023, km²

	Water	Crops	Built-up	Alpine	Subalp	Meadow-steppe	Steppe	Grasslands in forest zone	Forests	Juniper	Broadleaf woodland	Semidesert	Desert	Marsh	Total
Aragatsotn	3.4	443.4	140.3	204.5	107.1	502.7	517.5	42.9	48.9	0	0	746.6	0	5.3	2762.6
Ararat	37.9	303.4	176.6	37.2	62.9	30.8	733.2	176.2	26.1	0	9.5	444.1	6.9	49.8	2094.6
Armavir	6.7	609.6	183.2	0	0	0	0	0	0.4	0	0	448.8	0	6.9	1255.6
Gegharkunik	28.2	407.2	192.9	389.9	1280.8	400.3	817.8	227	127.9	20.8	10.6	0	0	92.8	3996.2
Kotayk	2.6	267.5	183.8	113.9	175.9	221.7	451.6	272.6	155.1	0	1.7	278.8	0	8.2	2133.4
Lori	4.7	307.2	151.5	45	847.9	649.5	337.3	526.4	899.2	0	41.8	0	0	31.3	3841.8
Shirak	30.9	758	145.5	128.3	403.9	413.5	823.9	0	13.7	0	0	17.3	0	29	2764
Syunik	15	228.7	72	524.3	813.1	291.1	781.4	871.8	487.4	12.6	145.7	110.2	0	6.5	4359.8
Tavush	4.4	82.1	97.7	0.3	210.9	0	6.5	534	1343.7	0	483.5	0	0	0	2763.1
Vayots Dzor	2.3	32.9	44.9	210.7	385.1	77.7	763.3	246	37.9	96.3	4.6	364.7	0	0.8	2267.2
Total	136.1	3440	1388.4	1654.1	4287.6	2587.3	5232.5	2896.9	3140.3	129.7	697.4	2410.5	6.9	230.6	28238.3

2.3.B. Ecosystem rarity in Armenia

Currently, desert, juniper, and marsh zones have the smallest natural areas (less than 1% of Armenia's area). Broadleaf woodlands are also rare (2%). The most widespread are steppe and subalpine meadows (18% and 14%) followed by forests (11%). Other types of grasslands account from 6% to 10% of Armenia's area and can be considered common (Fig. 2.3.B-1, 2.3.B-2).

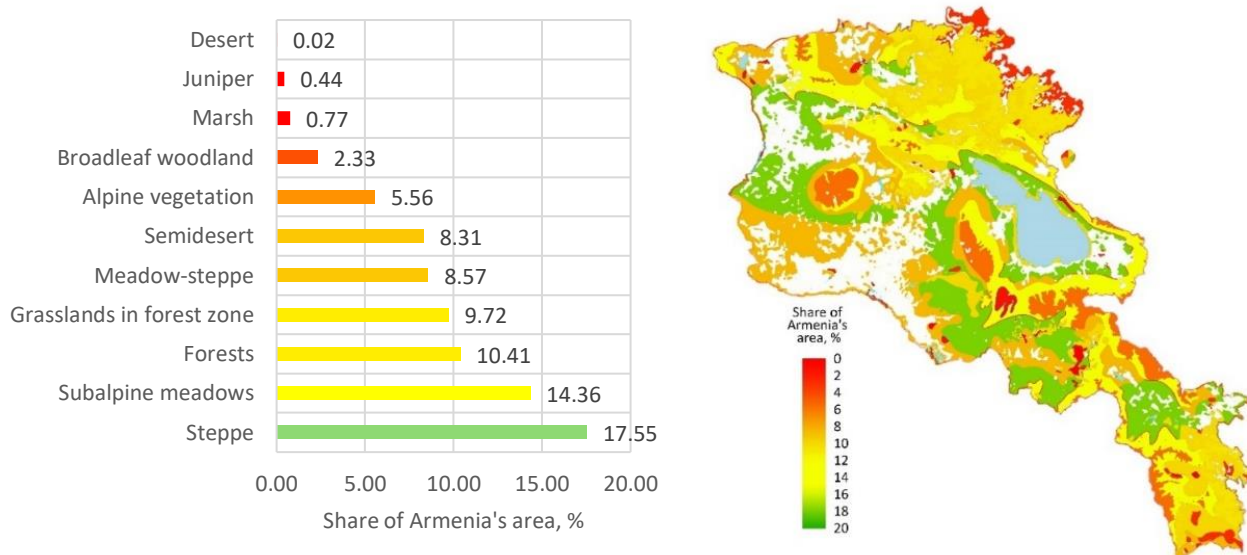

Figure 2.3.B-1. Ranking of ecosystem types by rarity (a) and the map of ecosystem rarity (b)

To assess the importance of marzes for conserving ecosystem diversity in Armenia, we used the indicator of the share of the national area of ecosystem types that is conserved within the marzes and the sum of these values in marzes (Table 2.3.B-1). This approach was applied to ensure that the value of rare ecosystems is not diminished. According to this criterion, the marz of Ararat is the most important for conserving Armenia's ecosystem diversity, as it contains the country's only desert area (100%). The high value of Syunik marz is determined by the fact that it encompasses the full range of ecosystem types. The contribution of Gegharkunik is largely determined by the high proportion of marshes located within it, and the contribution of Vayots Dzor by the high proportion of juniper woodlands (Figure 2.3.B-2).

Table 2.3.B-1. Share of the national area of ecosystem types that is conserved within the marzes, %.

	Alpine veg.	Subalpine meadows	Meadow-steppe	Steppe	Grasslands in forest zone	Forests	Juniper	Broadleaf woodland	Semidesert	Desert	Marsh	Total
Aragatsotn	12.36	2.50	19.43	9.89	1.48	1.56	0.00	0.00	30.97	0.00	2.30	80.49
Ararat	2.25	1.47	1.19	14.01	6.08	0.83	0.00	1.36	18.42	100.00	21.60	167.21
Armavir	0.00	0.00	0.00	0.00	0.00	0.01	0.00	0.00	18.62	0.00	2.99	21.62
Gegharkunik	23.57	29.87	15.47	15.63	7.84	4.07	16.04	1.52	0.00	0.00	40.24	154.25
Kotayk	6.89	4.10	8.57	8.63	9.41	4.94	0.00	0.24	11.57	0.00	3.56	57.90
Lori	2.72	19.78	25.10	6.45	18.17	28.63	0.00	5.99	0.00	0.00	13.57	120.42
Shirak	7.76	9.42	15.98	15.75	0.00	0.44	0.00	0.00	0.72	0.00	12.58	62.63
Syunik	31.70	18.96	11.25	14.93	30.09	15.52	9.71	20.89	4.57	0.00	2.82	160.46
Tavush	0.02	4.92	0.00	0.12	18.43	42.79	0.00	69.33	0.00	0.00	0.00	135.61
Vayots Dzor	12.74	8.98	3.00	14.59	8.49	1.21	74.25	0.66	15.13	0.00	0.35	139.39
Total	100.00	100.00	100.00	100.00	100.00	100.00	100.00	100.00	100.00	100.00	100.00	

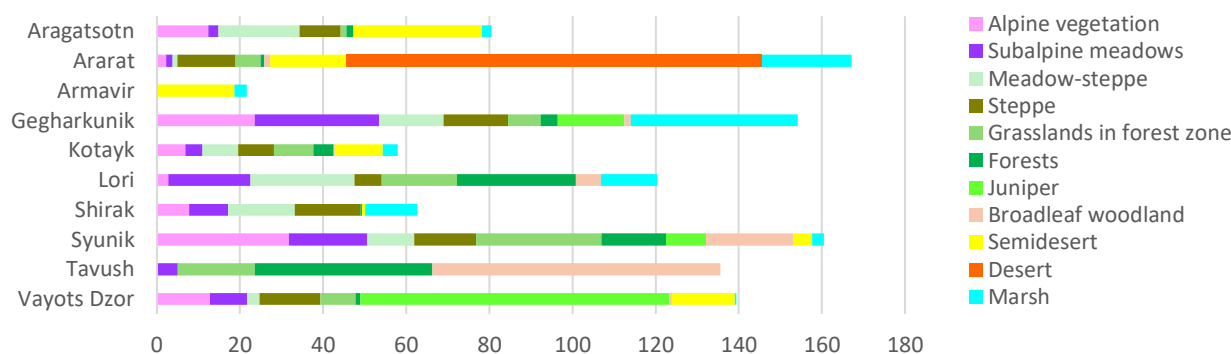

Figure 2.3.B-2. The sum of the shares (%) of the national area of ecosystem types that are conserved within the marzes.

2.3.C. Changes in ecosystem extent from 2017 to 2023

The vegetation-type transition matrix shows how areas of vegetation zones transitioned into land-cover classes (e.g., steppe vegetation converting to croplands, built-up, bare ground, or tree cover, and vice versa). Zone-to-zone vegetation transitions are not recorded in PV1, because the zone boundaries did not change. Table 2.3.C-1 presents aggregated data: bare ground and snow/ice are added to the natural area of the corresponding vegetation zone, and the areas of water and flooded vegetation are combined (for full matrix see Appendix 2.3.C-1; for matrix of relative changes see Appendix 2.3.C-2). Data on transitions from the natural areas of vegetation zones to anthropogenic territories and to tree cover—and back—allow us to populate rows “Additions to extent” and “Reductions in extent” in the accounting table (Table 2.3.C-2).

Table 2.3.C-1. Aggregated vegetation type transition matrix from 2017 to 2023, km²

	Alpine veg.	Subalpine mead.	Meadow-steppe	Steppe	Grassl. in forest zone	Juniper	Broadleaf woodl.	Semi-desert	Desert	Marsh	Forests	Water and flood. veg.	Crops	Built-up	Total area in 2017	Reduction
Alpine	1642.9	0.0	0.0	0.0	0.0	0.0	0.0	0.0	0.0	0.0	0.4	0.2	2.3	0.1	1645.9	3.0
Subalpine	0.0	4216.6	0.0	0.0	0.0	0.0	0.0	0.0	0.0	0.0	19.6	0.5	60.9	2.9	4300.5	83.8
Meadow-steppe	0.0	0.0	2552.1	0.0	0.0	0.0	0.0	0.0	0.0	0.0	10.9	2.3	270.0	6.2	2841.5	289.4
Steppe	0.0	0.0	0.0	5039.5	0.0	0.0	0.0	0.0	0.0	0.0	11.3	1.0	370.2	21.3	5443.2	403.8
Grassl. in forest zone	0.0	0.0	0.0	0.0	2628.1	0.0	0.0	0.0	0.0	0.0	143.6	1.4	54.9	22.2	2850.2	222.1
Juniper	0.0	0.0	0.0	0.0	0.0	127.5	0.0	0.0	0.0	0.0	0.9	0.0	0.2	0.2	128.8	1.2
Broadleaf woodl.	0.0	0.0	0.0	0.0	0.0	0.0	640.4	0.0	0.0	0.0	36.2	2.5	24.9	6.6	710.6	70.2
Semi-desert	0.0	0.0	0.0	0.0	0.0	0.0	0.0	2274.9	0.0	0.0	1.1	4.4	142.5	55.8	2478.5	203.6
Desert	0.0	0.0	0.0	0.0	0.0	0.0	0.0	0.0	6.8	0.0	0.0	0.0	0.0	0.3	7.1	0.3
Marsh	0.0	0.0	0.0	0.0	0.0	0.0	0.0	0.0	0.0	212.5	0.2	5.1	17.1	1.9	236.8	24.3
Forests	3.2	62.5	11.4	22.7	238.5	2.0	18.8	3.3	0.0	0.4	2909.9	0.6	3.7	2.7	3279.8	369.9
Water/flooded	0.2	0.4	1.2	0.8	1.8	0.0	0.6	4.2	0.0	5.3	0.5	110.9	9.2	2.4	137.5	26.6
Crops	1.3	12.6	20.3	162.8	21.8	0.0	35.5	179.1	0.1	11.5	3.0	7.8	2478.5	97.2	3031.7	553.2
Built-up	0.1	1.4	2.4	6.8	6.6	0.2	2.3	6.0	0.0	0.8	3.3	0.5	13.7	1336.6	1380.7	44.1
Total area in 2023	1647.6	4293.5	2587.4	5232.6	2896.8	129.7	697.7	2467.6	6.9	230.6	3140.7	137.1	3448.2	1556.3	28472.8	2295.5
Expansion	4.8	76.9	35.3	193.1	268.8	2.2	57.2	192.7	0.1	18.0	230.9	26.2	969.7	219.7	2295.5	

Table 2.3.C-2. Accounting table of vegetation type extent for 2017 and 2023, km²

	Alpine vegetation	Sub-alpine meadows	Meadow-steppe	Steppe	Grassl. in forest zone	Juniper	Broad-leaf woodland	Semi-desert	Desert	Marsh	Forests
Opening extent in 2017	1645.93	4300.46	2841.47	5443.24	2850.19	128.78	710.63	2478.53	7.06	236.81	3279.79
Additions to extent	4.76	76.90	35.29	193.11	268.77	2.17	57.23	192.71	0.06	18.04	230.88
Managed expansion	NA										
Unmanaged expansion	NA										
Reductions in extent	3.05	83.84	289.36	403.76	222.11	1.24	70.20	203.62	0.27	24.26	369.92
Managed reductions	NA										
Unmanaged reductions	NA										
Net change in extent	1.71	-6.94	-254.06	-210.66	46.66	0.93	-12.97	-10.92	-0.21	-6.22	-139.04
Closing extent in 2024	1647.64	4293.52	2587.41	5232.59	2896.85	129.71	697.67	2467.61	6.85	230.59	3140.75
Additional row – see discussion below											
Closing extent in 2024 of ecosystems unconverted since 2017	1642.88	4216.62	2552.11	5039.48	2628.08	127.54	640.43	2274.91	6.79	212.55	2909.87

The largest transformation areas are represented by transitions of various grassland types into croplands: 370 km² of steppes, 270 km² of meadow-steppes, 144 km² of semideserts, and 61 km² of subalpine meadows were converted into croplands. The total increase in cropland area amounted to 970 km² (Table 2.3.C-1; Figure 2.3.C-1). The reverse process—conversion of croplands back into grasslands—was weaker and could not compensate for their loss. The exceptions are semideserts and woodlands, where the reverse transition from croplands exceeded new agricultural expansion. Based on the formal ratio of areas over the six-year period, the intensity of agricultural development in these zones has decreased. The opposite trend is observed in meadow-steppes and alpine meadows, where reverse transitions are extremely small, indicating an increase in agricultural expansion intensity (Figure 2.3.C-2).

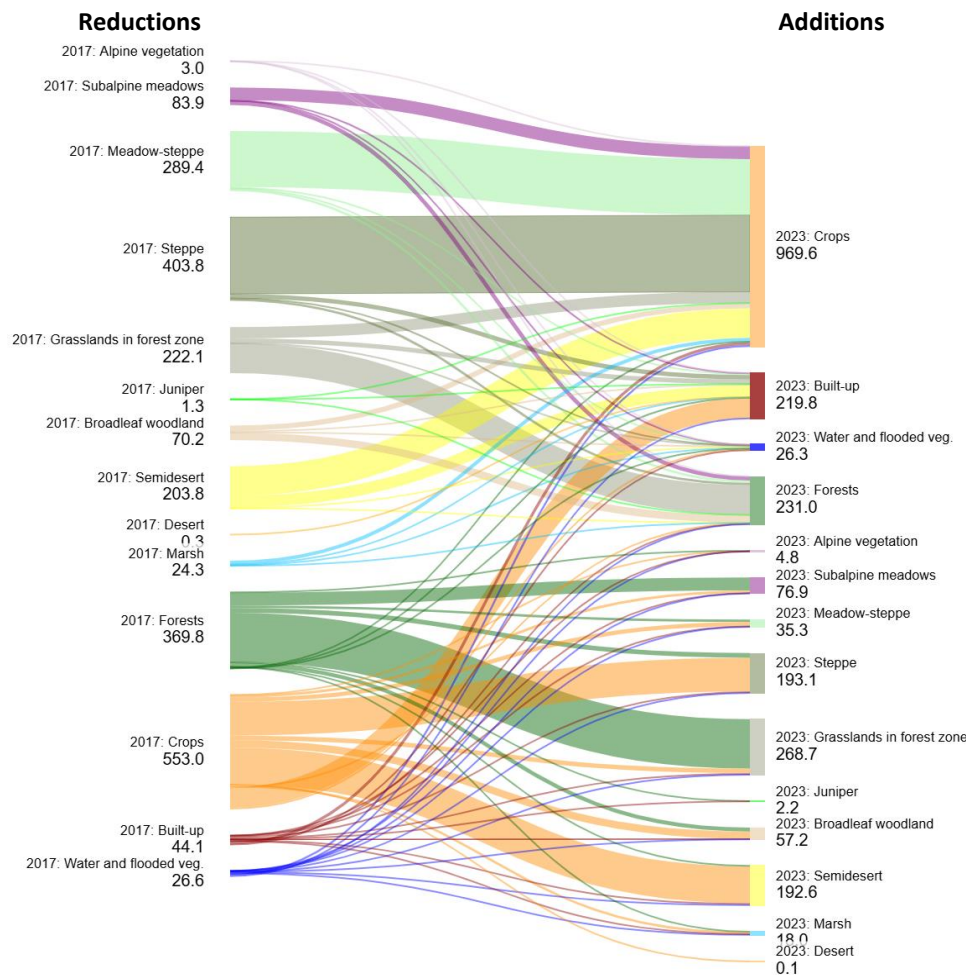

Figure 2.3.C-1. Transitions between vegetation zones and land cover classes. Self-transitions (categories remaining the same) are not shown. The total losses and gains in the diagram differ slightly from the Table 2.3.C-1 because they were computed by SankeyMATIC using a different rounding approach for totals.

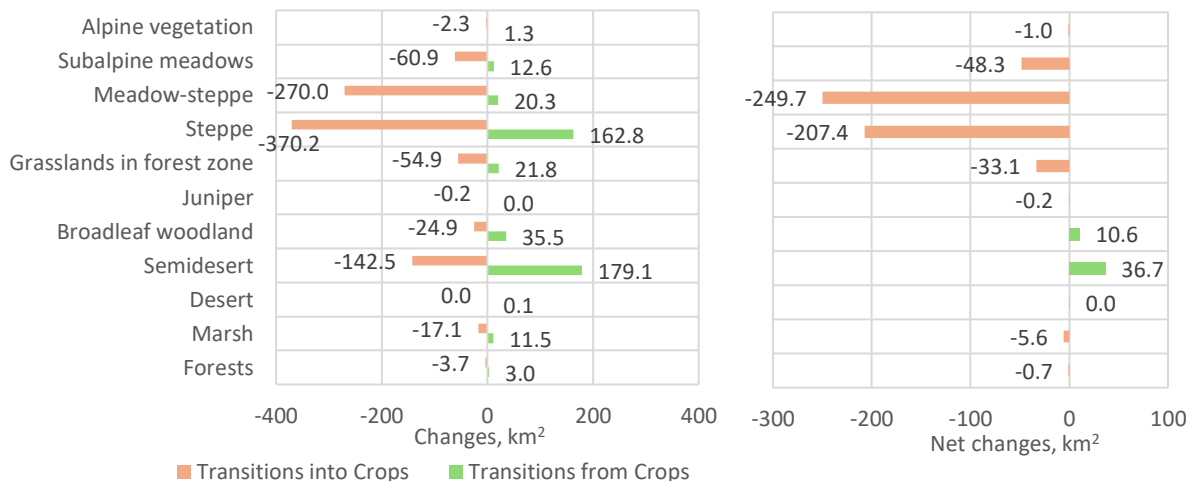

Figure 2.3.C-2. Transitions between vegetation zones and croplands

Considering not only the net extent changes but also the transitions between natural ecosystems and anthropogenic areas and vice versa is crucial for conserving biodiversity and maintaining ecosystems’ full capacity to provide ES. It is evident that any new additions to ecosystem area resulting from transitions out of croplands or built-up areas are merely nominal increases in area. In our case study, over six years the areas freed from cultivation and development did not recover into functioning ecosystems. In reality, these are abandoned fields or wastelands that, in terms of biodiversity and ecosystem functioning, are far from natural ecosystems. Thus, the closing extent for ecosystems that were not transformed during the reporting period equals the opening extent minus the reductions during the reporting period (Table 2.3.C-2). To set up accounting of unchanged natural ecosystems, it is advisable to designate areas converted from croplands and built-up areas as “abandoned fields and sites” within each vegetation zone. Under such accounting, their re-use will not reduce the reported extent of unchanged ecosystems.

Totally, from 2017 to 2023, the area of the most vegetation types not occupied by croplands and built-up areas decreased. The exceptions are grasslands in forest zone, juniper woodlands and alpine vegetation (Figure 2.3.C-3). The most significant reductions, both in absolute and relative terms, occurred in the meadow-steppes (254 km², 8.9% relative to area in 2017). Steppes and forests declined by roughly 4% (211 km² and 139 km², respectively). Reductions in other vegetation types are small in absolute terms—only a few square kilometers, and for desert just 0.2 km².

However, for conserving ecosystem diversity, not only absolute but also relative changes in area matter, especially for ecosystem types with a small total extent. Thus, the very small absolute changes in the area of marshes and desert correspond to relative declines of 2.6% and 3%, respectively comparable to the reductions in steppe and forest. In other words, for the purpose of conserving ecosystem diversity, they are no less important than the 100–200 km² losses observed for steppe and forest.

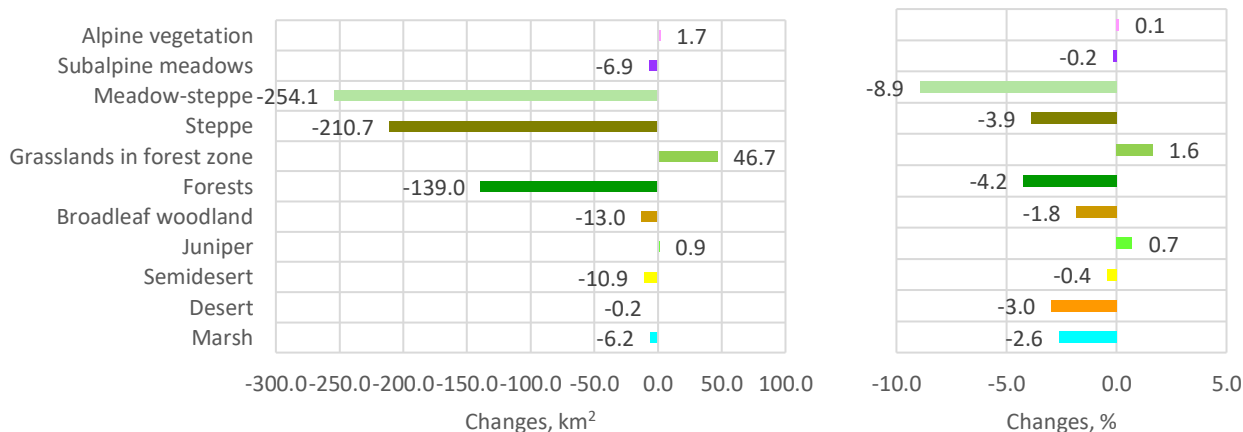

Figure 2.3.C-3. Net changes in area of vegetation types from 2017 to 2023

Changes in the natural vegetation types from 2017 to 2023 are small in absolute terms—on the order of tens of square kilometers or less. The most noticeable absolute losses of natural vegetation occurred in the steppe and meadow-steppe zones, especially in the Shirak, Gegharkunik, and Lori marzes, as well as in forests in the Syunik marz (Fig. 2.3.C-4a; Table

2.3.C-3). However, in relative terms (the share of area lost or gained relative to 2017, %), the largest loss of tree cover is in Armavir marz with very small total tree cover area. Changes in the area of marshes and broadleaf woodlands also become noticeable, whereas they are almost imperceptible in absolute terms (Fig. 2.3.C-4b; Table 2.3.C-3).

Table 2.3.C-3. Extent of natural vegetation types, anthropogenic land cover classes, and water (excluding Sevan Lake) by marzes in 2017 and in 2023 and changes in it

		Water	Crops	Built-up	Alpine	Subalp	Meadow-steppe	Steppe	Grasslands in forest zone	Forests	Juniper	Broadleaf woodland	Semidesert	Desert	Marsh	Total area of natural ecosystems
Extent in 2017, km ²	Aragatsotn	3.5	384	127.3	204.3	108.2	564.4	510.5	42.4	53.2	0	0	759.2	0	5.8	2248
	Ararat	39.8	356.1	144.3	37.2	62.6	30.8	730.7	174.7	30.4	0	9.5	425.1	7.1	46.2	1554.3
	Armavir	7.9	645.2	146.5	0	0	0	0	0	2.5	0	0	448	0	5.6	456.1
	Gegharkunik	28.9	316.6	182.4	389.3	1292.6	420.5	878	230.9	133.6	20.7	8.8	0	0	93.9	3468.3
	Kotayk	2.5	272.6	156.2	113.3	168.8	219.2	456.8	271.1	174	0	1.7	288.6	0	8.6	1702.1
	Lori	3.2	194.2	141.7	44.1	851.1	701.1	385.1	554.3	885.4	0	50.2	0	0	31.7	3503
	Shirak	27.2	547.7	140.2	127.9	427.1	512	910.9	0	13.4	0	0	17.4	0	40.2	2048.9
	Syunik	19.4	165.8	64.7	519.3	793.8	315.7	801.9	799.9	608.7	11.9	140.6	110.6	0	7.9	4110.3
	Tavush	4	91.6	93.1	0.3	205.2	0	5.9	536.6	1331.5	0	494.9	0	0	0	2574.4
	Vayots Dzor	2.8	34.9	39.3	210.7	385.2	77.7	763.4	240.2	46.8	96.2	4.7	364.6	0	0.7	2190.2
	Total	139.2	3008.7	1235.7	1646.4	4294.6	2841.4	5443.2	2850.1	3279.5	128.8	710.4	2413.5	7.1	240.6	23855.6
Extent in 2023, km ²	Aragatsotn	3.4	443.4	140.3	204.5	107.1	502.7	517.5	42.9	48.9	0	0	746.6	0	5.3	2175.5
	Ararat	37.9	303.4	176.6	37.2	62.9	30.8	733.2	176.2	26.1	0	9.5	444.1	6.9	49.8	1576.7
	Armavir	6.7	609.6	183.2	0	0	0	0	0	0.4	0	0	448.8	0	6.9	456.1
	Gegharkunik	28.2	407.2	192.9	389.9	1280.8	400.3	817.8	227	127.9	20.8	10.6	0	0	92.8	3367.9
	Kotayk	2.6	267.5	183.8	113.9	175.9	221.7	451.6	272.6	155.1	0	1.7	278.8	0	8.2	1679.5
	Lori	4.7	307.2	151.5	45.3	847.9	649.5	337.3	526.4	899.2	0	41.8	0	0	31.3	3378.7
	Shirak	30.9	758	145.5	128.3	403.9	413.5	823.9	0	13.7	0	0	17.3	0	29	1829.6
	Syunik	15	228.7	72	518.1	813.1	291.1	781.4	871.8	487.4	12.6	145.7	110.2	0	6.5	4037.9
	Tavush	4.4	82.1	97.7	0.3	210.9	0	6.5	534	1343.7	0	483.5	0	0	0	2578.9
	Vayots Dzor	2.3	32.9	44.9	210.7	385.1	77.7	763.3	246	37.9	96.3	4.6	364.7	0	0.8	2187.1
	Total	136.1	3440	1388.4	1648.2	4287.6	2587.3	5232.5	2896.9	3140.3	129.7	697.4	2410.5	6.9	230.6	23267.9
Change, km ²	Aragatsotn	0	59.4	13	0.1	-1.1	-61.7	7.1	0.4	-4.2	0	0	-12.6	0	-0.5	-72.5
	Ararat	-1.9	-52.8	32.4	-0.1	0.3	0	2.5	1.4	-4.3	0	0	19	-0.2	3.7	22.3
	Armavir	-1.2	-35.6	36.7	0	0	0	0	0	-2.1	0	0	0.9	0	1.3	0.1
	Gegharkunik	-0.7	90.6	10.5	0.6	-11.8	-20.2	-60.2	-3.9	-5.7	0	1.8	0	0	-1.1	-100.5
	Kotayk	0.1	-5.1	27.6	0.6	7.1	2.5	-5.3	1.5	-18.9	0	0	-9.7	0	-0.4	-22.6
	Lori	1.5	113	9.8	1.1	-3.1	-51.6	-47.8	-27.9	13.8	0	-8.4	0	0	-0.4	-124.3
	Shirak	3.7	210.3	5.2	0.4	-23.2	-98.5	-86.9	0	0.3	0	0	-0.1	0	-11.2	-219.2
	Syunik	-4.4	62.8	7.3	-1.1	19.3	-24.6	-20.5	71.9	-121.3	0.7	5.1	-0.4	0	-1.4	-72.3
	Tavush	0.4	-9.4	4.6	0	5.6	0	0.6	-2.6	12.2	0	-11.4	0	0	0	4.4
	Vayots Dzor	-0.4	-1.9	5.6	0	-0.1	0	-0.1	5.7	-8.9	0.2	-0.1	0	0	0	-3.3
	Total	-2.9	431.3	152.7	1.7	-7	-254.1	-210.6	46.5	-139.1	0.9	-13	-2.9	-0.2	-10	-587.9
Change, relative to 2017, %	Aragatsotn	-0.2	15.5	10.2	0.1	-1	-10.9	1.4	1	-8	0	0	-1.7	0	-8.7	-3.2
	Ararat	-4.9	-14.8	22.4	-0.2	0.5	0.1	0.3	0.8	-14.1	0	0	4.5	-3	7.9	1.4
	Armavir	-14.9	-5.5	25	0	0	0	0	0	-83.5	0	0	0.2	0	23.1	0.0
	Gegharkunik	-2.3	28.6	5.7	0.2	-0.9	-4.8	-6.9	-1.7	-4.2	0.1	20.5	0	0	-1.2	-2.9
	Kotayk	3.2	-1.9	17.7	0.6	4.2	1.2	-1.2	0.6	-10.9	0	0.1	-3.4	0	-4.6	-1.3
	Lori	48.3	58.2	6.9	2.5	-0.4	-7.4	-12.4	-5	1.6	0	-16.7	0	0	-1.1	-3.5
	Shirak	13.7	38.4	3.7	0.3	-5.4	-19.2	-9.5	0	2.3	0	0	-0.5	0	-27.9	-10.7
	Syunik	-22.8	37.9	11.2	-1	2.4	-7.8	-2.6	9	-19.9	6.2	3.7	-0.4	0	-17.3	-1.8
	Tavush	9.3	-10.3	5	0	2.7	0	10.3	-0.5	0.9	0	-2.3	0	0	0	0.2
	Vayots Dzor	-14.9	-5.5	14.2	0	0	0	0	2.4	-19	0.2	-2.1	0	0	0.6	-0.2

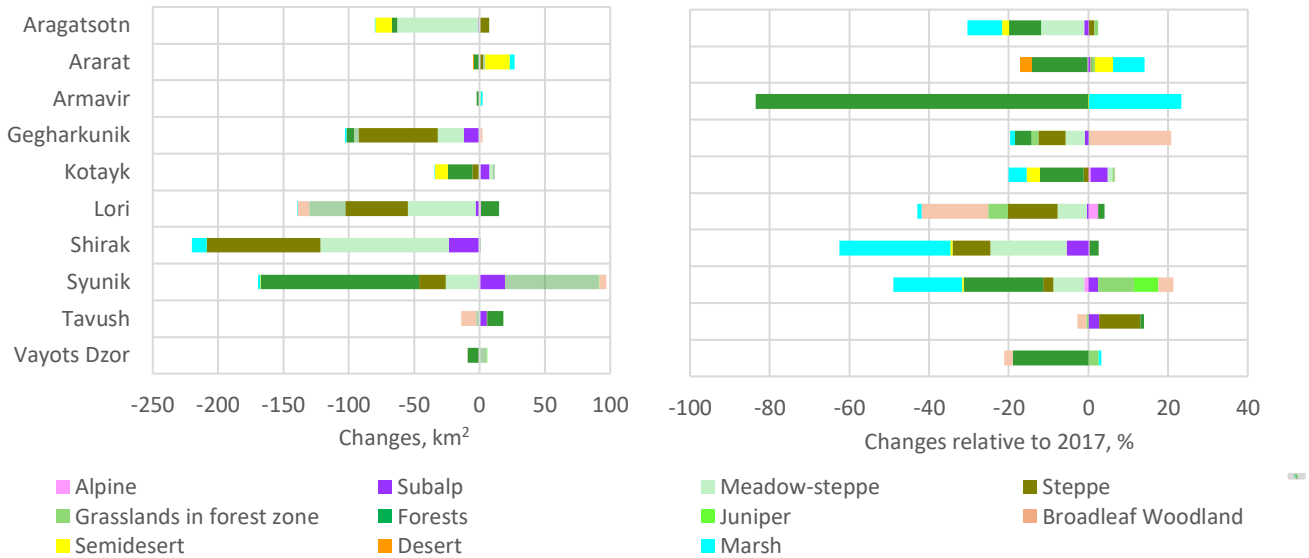

Figure 2.3.C-4. Changes in natural areas of vegetation types by provinces from 2017 to 2023: a) absolute changes, km²; b) share of lost/gained area, % relative to 2017.

2.3.D. Reduction of the potential area of vegetation types identified on the 1961 vegetation map

For this analysis, the vegetation map from the 1961 Atlas of the Armenian SSR (1961), digitized by Vardan Asatryan, and the Esri land cover data for 2023 were used. The current distribution of vegetation types was considered as potential vegetation zones (Figure 2.3.D-1 a), excluding croplands and built-up areas based on Esri data for 2023 (Figure 2.3.D-1 b).

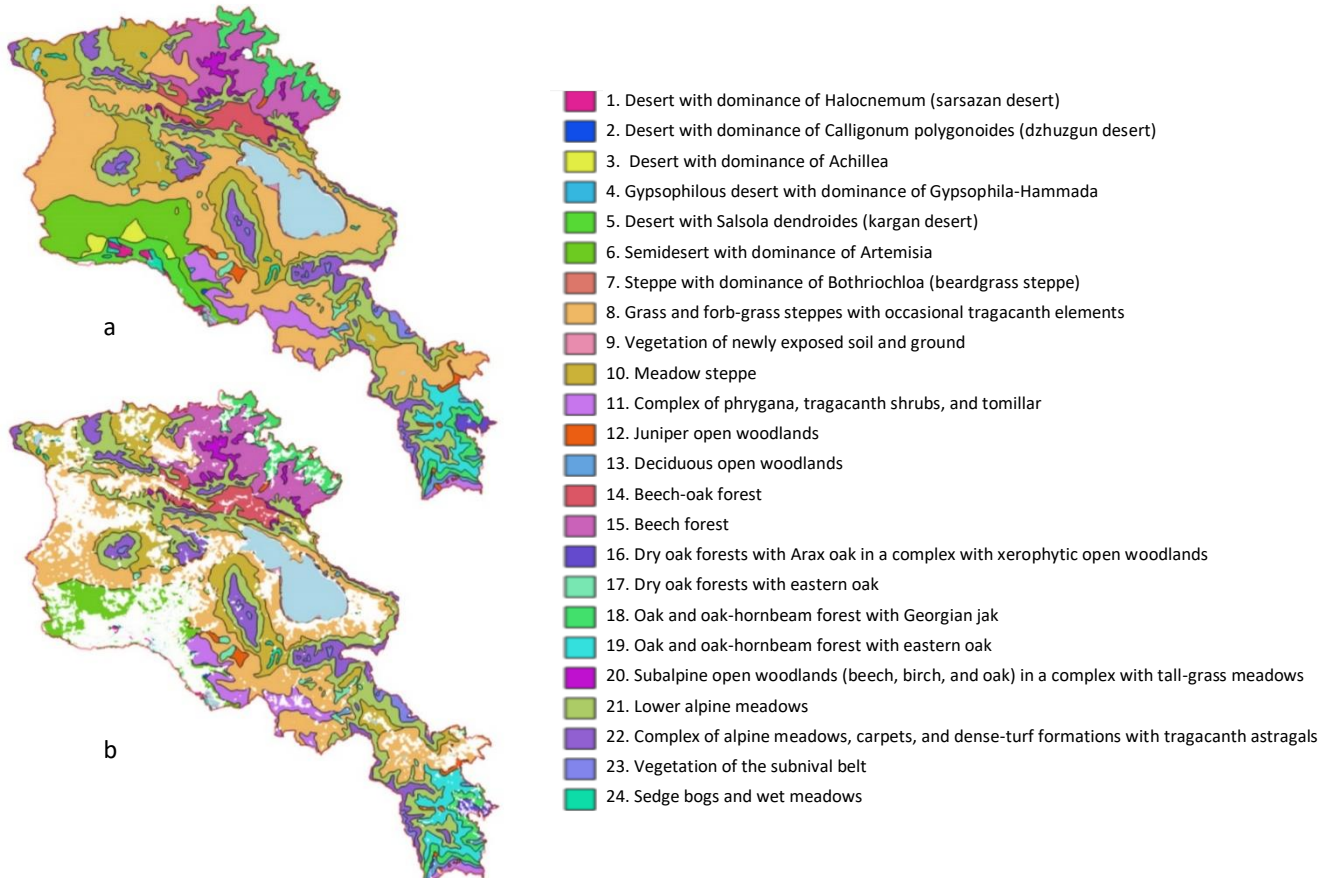

Figure 2.3.D-1. Vegetation map of 1961: a) potential vegetation; b) vegetation excluding croplands and built-up areas in 2023. For detailed maps see project Web GIS (<https://bccarmenia.nextgis.com/>), section Ecosystem Extent/Vegetation

Ranking of vegetation types by their current rarity (Figure 2.3.D-2) shows that, at present, all desert types (1–5) as well as steppe with dominance of *Bothriochloa* (type 7) are the rarest. Each of them occupies less than 100 km². The potential distribution areas of the two rarest desert types (2 and 4), each occupying less than 10 km², have largely preserved and mostly not covered by croplands or built-up areas according to Esri data. The distribution area of steppe with dominance of *Bothriochloa* (7) also appears to be relatively well preserved.

The most severely affected was the desert with dominance of *Achillea* (3), of which only 7% remains, as well as the desert with *Salsola dendroides* (5), with only 16% remaining. The distribution area of desert with dominance of *Halocnemum* (1) has also been significantly reduced, with 43% remaining. These three vegetation types have experienced the greatest decline among all types shown on the map.

Relatively rare vegetation types occupying between 100 and 200 km² — deciduous and juniper open woodland (12, 13) and variants of oak forests (16, 17) — have relatively well-preserved distribution areas, with 85–99% remaining.

Among the more widespread vegetation types, occupying between 200 and 1,000 km², a significant reduction was observed only for sedge bogs and wet meadows (type 24), which declined to 63%. The distribution areas of other types — subnival vegetation, subalpine open woodlands, variants of oak and birch-oak forests, as well as shrublands — have been largely unaffected by human activity, with 94–100% of their area remaining intact.

Among the common and widespread vegetation types occupying more than 1,000 km², significant reductions have occurred in semi-desert with dominance of *Artemisia* (type 6) with 57% remaining and the most widespread vegetation zone - grass and forb-grass steppes (type 8) with 75% remaining, both of which are located in areas of arable agriculture.

Table 2.3.D-1. Potential and current areas of vegetation types and the degree of their preservation

Vegetation zones	Total potential distribution area, km ²	Area not occupied by croplands and built-up areas in 2023, km ²	Area share not occupied by croplands and built-up areas relative to the total potential distribution area, %
1. Desert with dominance of <i>Halocnemum</i> (sarsazan desert)	135.1	57.5	42.5
2. Desert with dominance of <i>Calligonum polygonoides</i> (dzhuzgun desert)	7.4	6.6	89.6
3. Desert with dominance of <i>Achillea</i>	256.0	17.6	6.9
4. Gypsophilous desert with dominance of <i>Gypsophila-Hammada</i>	9.8	8.1	82.6
5. Desert with <i>Salsola dendroides</i> (kargan desert)	582.7	95.3	16.4
6. Semidesert with dominance of <i>Artemisia</i>	2107.2	1201.5	57.0
7. Steppe with dominance of <i>Bothriochloa</i> (beardgrass steppe)	39.1	31.3	80.0
8. Grass and forb-grass steppes with occasional tragacanth elements	8614.1	6464.9	75.1
9. Vegetation of newly exposed soil and ground	124.5	107.8	86.6
10. Meadow steppe	3347.4	2781.2	83.1
11. Complex of phrygana, tragacanth shrubs, and tomillar	944.1	886.5	93.9
12. Juniper open woodlands	209.5	198.9	94.9
13. Deciduous open woodlands	153.5	151.6	98.8
14. Beech-oak forest	650.5	625.7	96.2
15. Beech forest	1934.6	1884.0	97.4
16. Dry oak forests with Arax oak in a complex with xerophytic open woodlands	143.1	121.1	84.6
17. Dry oak forests with eastern oak	200.9	199.1	99.1
18. Oak and oak-hornbeam forest with Georgian jak	1252.1	1088.1	86.9
19. Oak and oak-hornbeam forest with eastern oak	737.8	728.2	98.7
20. Subalpine open woodlands (beech, birch, and oak) in a complex with tall-grass meadows	360.6	360.5	100.0
21. Lower alpine meadows	4398.9	4370.6	99.4
22. Complex of alpine meadows, carpets, and dense-turf formations with tragacanth astragals	1932.9	1919.6	99.3
23. Vegetation of the subnival belt	246.7	245.7	99.6
24. Sedge bogs and wet meadows	327.8	207.2	63.2

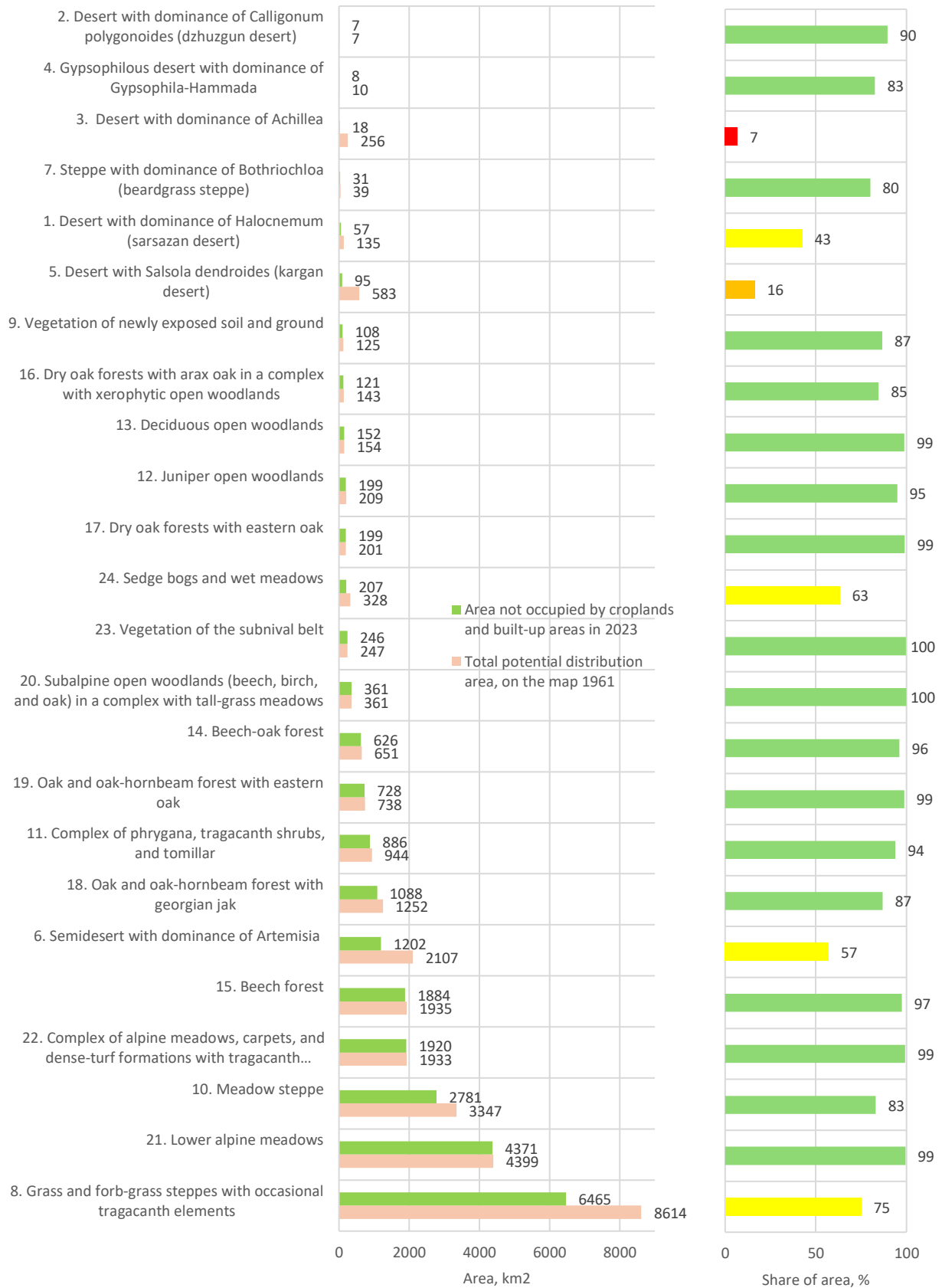

Figure 2.3.D-2. Potential area of vegetation types and their current state: a) potential area of each vegetation type and the area remaining as of 2023; vegetation types are ranked by their rarity in 2023; b) share of the area not occupied by croplands and built-up areas relative to the total potential distribution area, %.

2.4. Extent of natural landscapes

2.4.A. Extent of natural landscapes in Armenia

To estimate extent of natural landscapes, the map of landscape zones published in the Fifth National Report of Armenia to the CBD (2014) was used (available in digital form in Forest Atlas of Armenia [FAA](#)), along with Esri land cover data for 2017 and 2023 as well as ESA 2021 data for comparison (Fig. 24A-1).

The area of natural landscapes was calculated as the area of a given landscape zone minus waterbodies and anthropogenically transformed territories, that is, built-up areas and croplands.

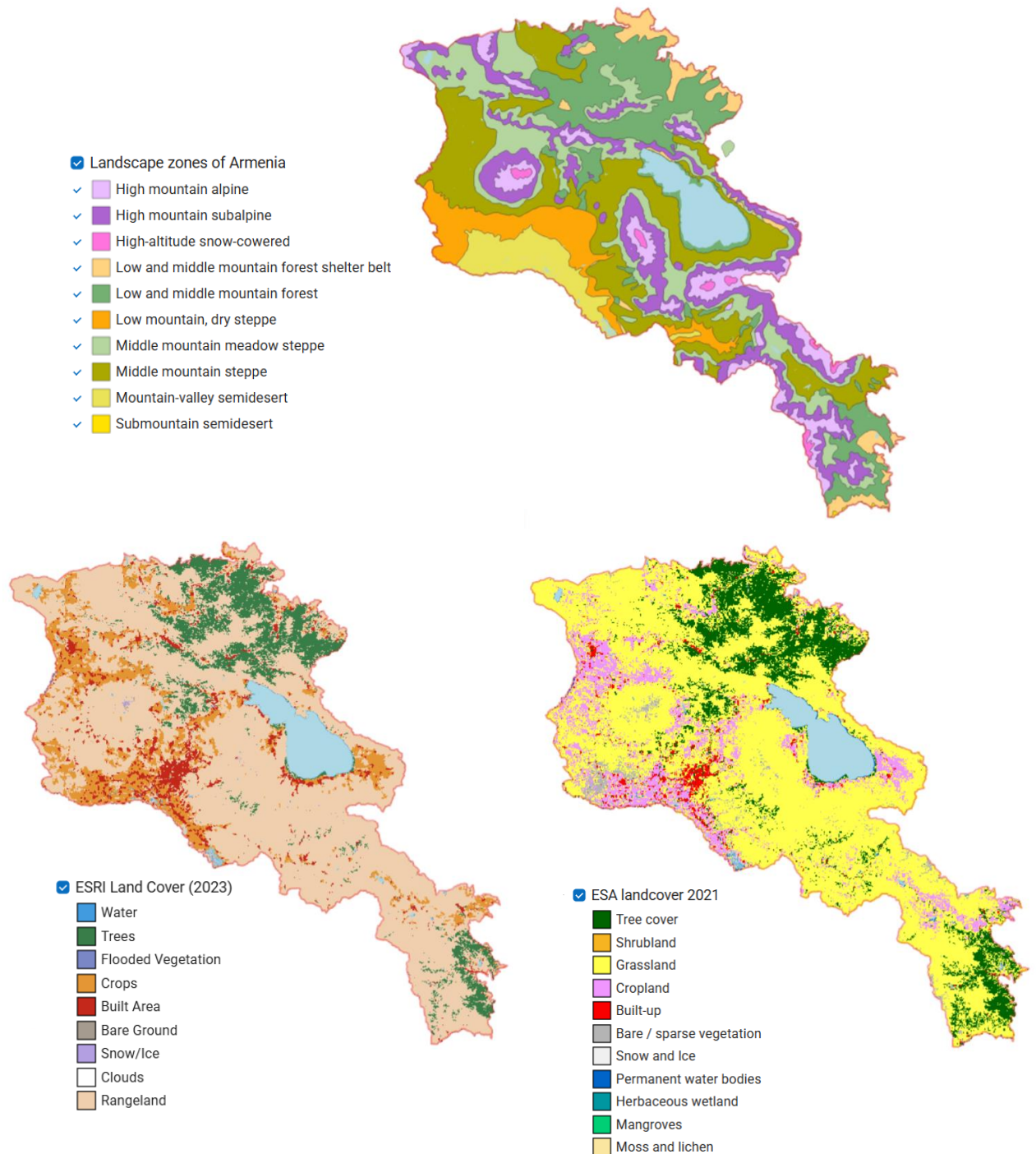

Figure 2.4.A-1. The maps used for estimation of the extent of natural landscapes. For detailed maps see project Web GIS (<https://bccarmenia.nextgis.com/>), section "Ecosystem extent"

According to Esri data, the most human-transformed zone is mountain-valley semi-desert, where only 27% of natural landscapes remain. It is followed by low mountain dry steppe and the middle mountain steppe zones, with 65% and 71% of natural landscapes remaining, respectively. High-mountain snow-covered, alpine, and subalpine zones have been almost unaffected by human activity. Forests are most widespread in zones of low-middle mountain forest (38%) and low-middle mountain forest shelter belt (17%). There are almost no forests in the half of landscape zones - high-altitude snow-covered, alpine, dry steppe, and semi-deserts (Figures 2.4.A-2 and 2.4.A-3; Table 2.4.A-1).

ESA data show a generally similar picture, but with smaller built-up area and larger area of tree cover and bare ground, which is particularly noticeable in the semi-deserts, dry steppe, and forest shelter belt (Figure 2.4.A-2 and 2.4.A-3; Table 2.4.A-2). One of the reasons for this is that, as mentioned above, ESA identifies trees within settlements. The presence of trees in submountain semidesert zone in the ESA data is entirely due to this factor – all trees there are located inside settlements (see Section 2.1.A). In the semi-desert zone, some areas classified by Esri as croplands were identified by ESA as bare ground and grasslands. As a result, the degree of transformation of this zone is considerably lower in ESA data than in Esri data.

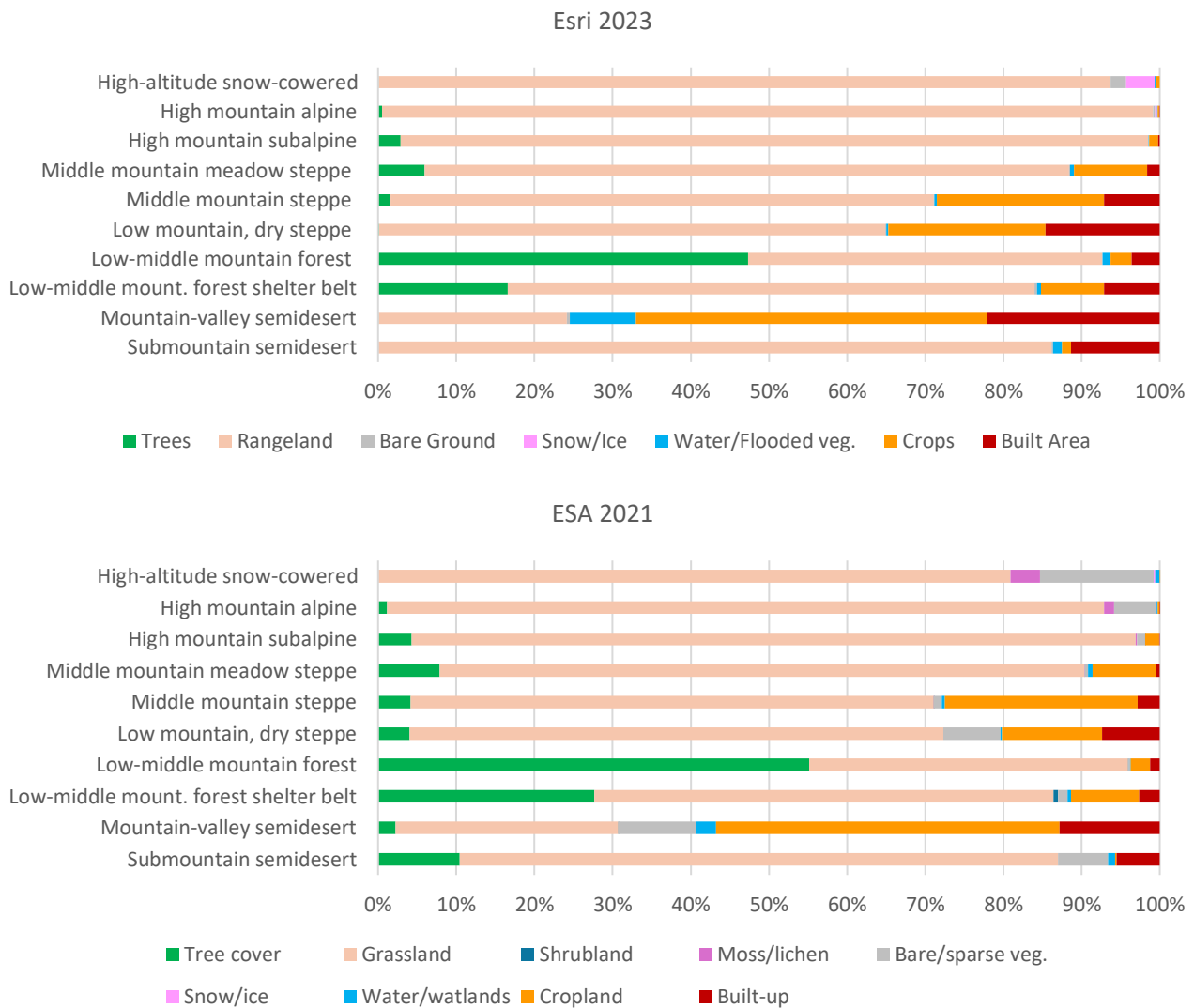

Figure 2.4.A-2. Share of land cover classes within landscape zones according Esri 2023 and ESA 2021 data

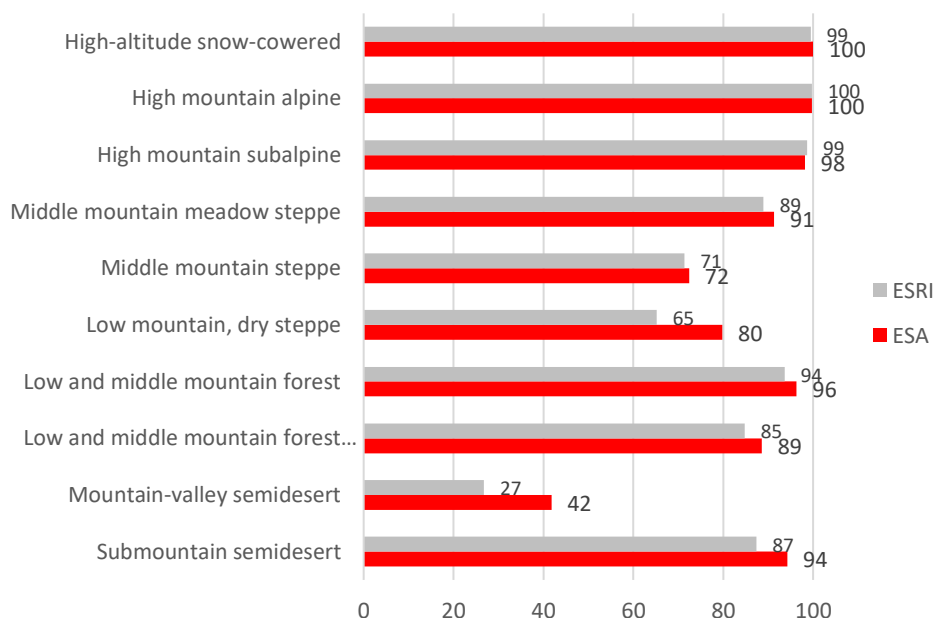

Figure 2.4.A-3. Share of area of natural land cover classes within landscape zones (%) according Esri and ESA data

Table 2.4.A-1. Area of land cover classes within landscape zones according to Esri 2023 data, km²

	Trees	Rangeland	Bare Ground	Snow/ Ice	Water/ Flooded veg.	Crops	Built Area	Total
High-altitude snow-covered	0.06	183.27	3.83	7.09	0.32	1.01	0.00	195.58
High mountain alpine	9.90	1948.68	5.67	4.45	1.83	3.72	1.38	1975.62
High mountain subalpine	125.93	4222.75	3.73	0.00	2.73	49.13	10.25	4414.52
Middle mountain meadow steppe	294.31	4057.45	4.27	0.00	27.14	460.92	78.35	4922.44
Middle mountain steppe	108.88	4723.60	2.97	0.00	20.69	1454.46	484.65	6795.24
Low mountain, dry steppe	3.21	1461.86	3.35	0.00	5.61	454.76	329.90	2258.69
Low-middle mountain forest	2361.03	2261.51	2.81	0.00	50.26	133.77	180.49	4989.87
Low-middle mount. forest sh. belt	195.79	796.09	3.87	0.00	6.34	95.20	84.08	1181.37
Mountain-valley semidesert	0.52	411.32	5.75	0.00	144.50	766.06	376.07	1704.21
Submountain semidesert	0.00	14.93	0.03	0.00	0.20	0.19	1.97	17.33
Sevan	0	0	0	0	1227	0	0	1227.00

Table 2.4.A-2. Area of land cover classes within landscape zones according to ESA 2021 data, km²

	Tree cover	Grass-land	Shrub -land	Moss/ lichen	Bare/ sparse veg.	Snow/ ice	Water/ floode d	Crop-land	Built-up	Total
High-altitude snow-covered	0.01	189.85	0.00	8.91	34.14	0.44	1.37	0.00	0.00	234.72
High mountain alpine	22.95	1814.63	0.00	25.59	106.82	0.11	2.24	5.78	0.11	1978.24
High mountain subalpine	189.42	4066.87	0.00	6.11	45.19	0.01	1.87	78.13	3.13	4390.74
Middle mountain meadow steppe	391.79	4088.71	0.00	0.92	21.20	0.00	28.58	404.81	22.02	4958.03
Middle mountain steppe	283.17	4578.27	0.18	0.00	69.91	0.00	23.36	1688.78	191.46	6835.12
Low mountain, dry steppe	90.96	1549.08	0.00	0.00	165.79	0.00	5.12	289.93	167.83	2268.72
Low-middle mountain forest	2751.63	2034.38	2.97	0.00	10.54	0.00	3.74	122.38	62.19	4987.84
Low-middle mount. forest sh. belt	327.59	695.87	6.82	0.00	14.03	0.00	5.26	103.17	31.54	1184.29
Mountain-valley semidesert	36.26	458.47	0.00	0.00	160.83	0.00	39.78	706.90	206.75	1608.98
Submountain semidesert	1.78	13.08	0.00	0.00	1.09	0.00	0.16	0.03	0.94	17.08
Sevan	0.00	0.00	0.00	0.00	0.00	0.00	1279.24	0.00	0.00	1279.24

The extent of natural areas within landscape zones differs significantly from the total extent of those zones (Figure 2.4.A-4). When comparing the total area of the landscape zones, middle mountain steppes far exceed all other landscape zones. However, if anthropogenic areas are excluded, four types of natural landscapes have similar extents, each covering 15–16% of Armenia’s territory – middle mountain steppe and meadow steppe, subalpine and forest zones. Mountain-valley semi-desert zone is shrinking the most – from 5.4% to 1.4-2.3% – as it has been transformed by human activity to the greatest extent. Differences in the estimated extent of natural landscapes between Esri and ESA are greatest for the zones most heavily transformed by human activity, as ESA identifies smaller areas of croplands and built-up land (see above).

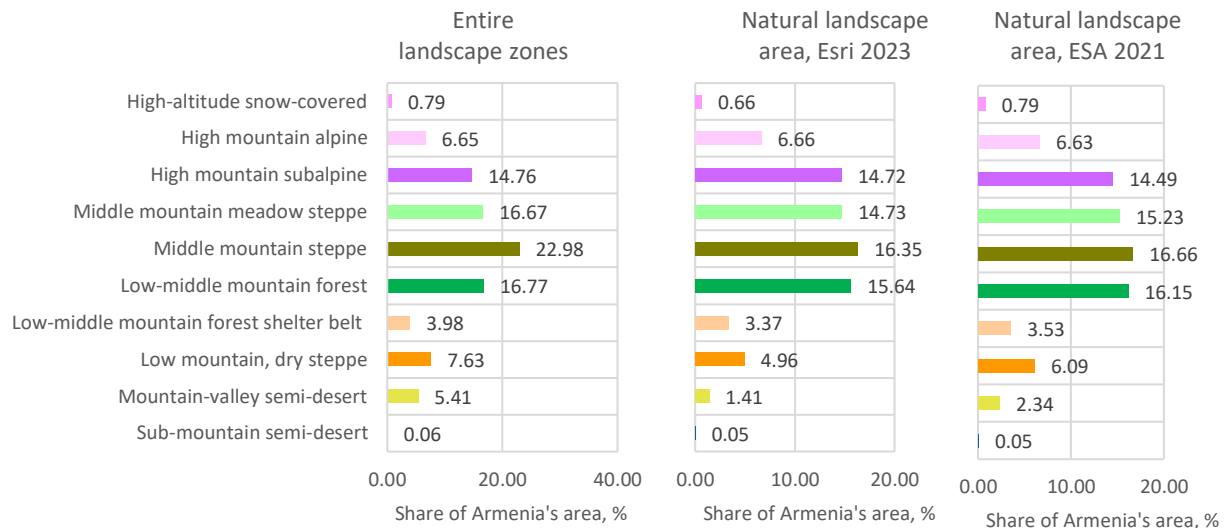

Figure 2.4.A-4. The share of landscape zones and natural landscapes in Armenia's total area, %

2.4.B. Changes in extent of natural landscapes from 2017 to 2023 based on Esri data

The extent of most natural landscapes decreased from 2017 to 2023 due to the expansion of human-occupied areas (croplands and built-up zones), as described in the Section 2.2.B. A noticeable increase in natural areas was observed only in mountain-valley semi-desert in Armavir and Ararat marzes (see Section 2.4.C below).

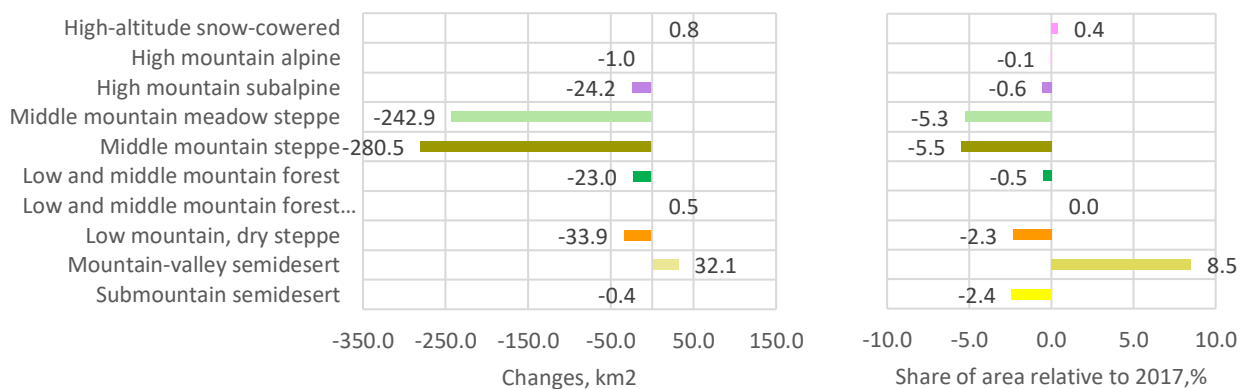

Figure 2.4.B-1. Absolute and relative changes in natural landscape extent

2.4.C. Natural landscape extent at marz level

In terms of the extent of natural landscapes in marzes, Esri and ESA provide a very similar picture. The main part of the forest landscape zone is located in three marzes — Lori, Tavush, and Syunik. The largest areas of alpine and subalpine landscapes are found in Syunik and Gegharkunik, although these landscapes are also notably present in all other marzes except Armavir and Tavush. Steppe landscapes are present in all marzes, but in Tavush and Armavir, where their area is small. The remaining natural areas of mountain-valley semi-desert are mainly located in the Ararat and Armavir marzes. Submountain semi-desert is represented by small patches only in the south of Syunik marz (Figure 2.4.C-1; Tables 2.4.C-1, 2.4.C-2).

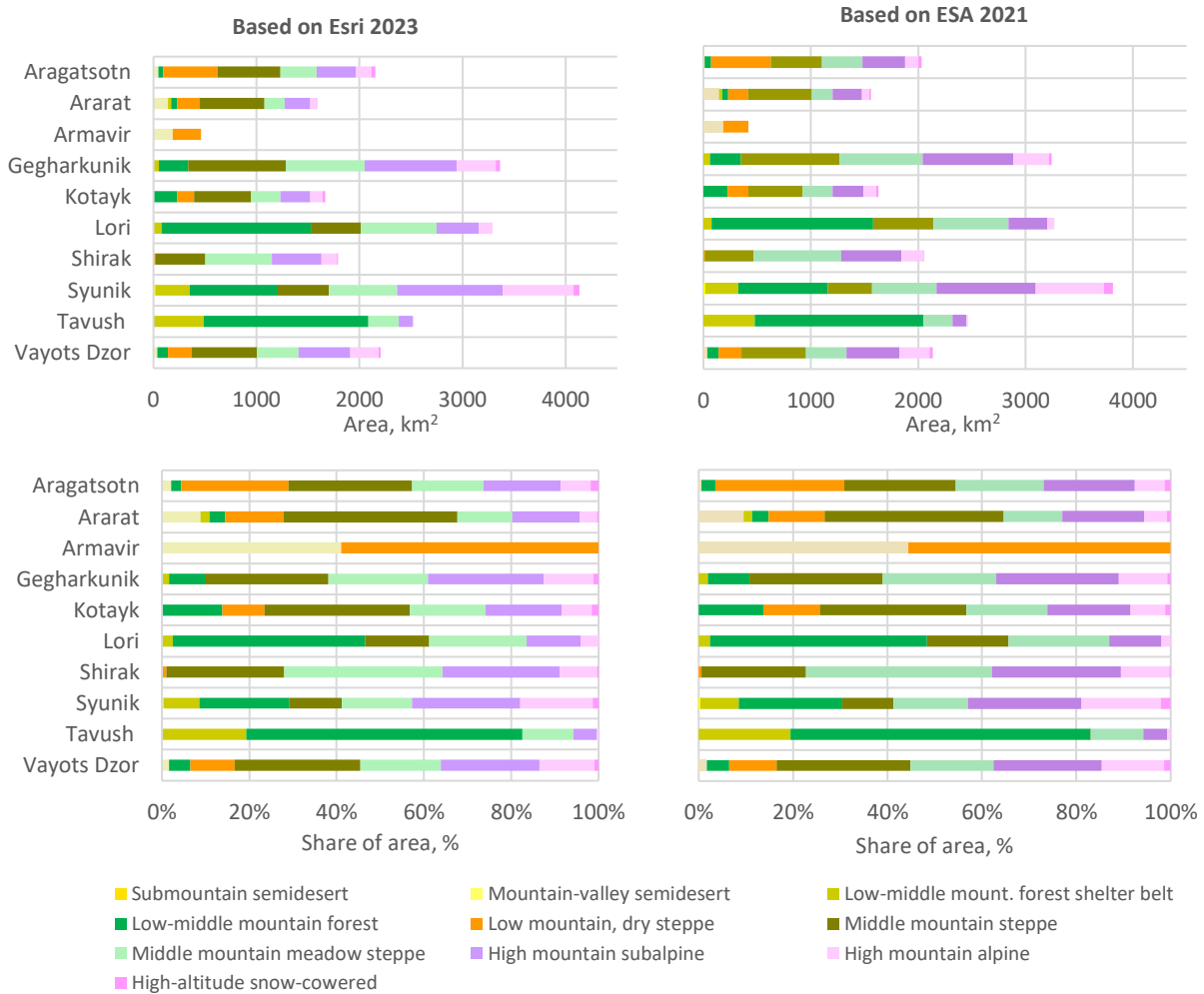

Figure 2.4.C-1. Area and share of natural landscapes in marzes.

Table 2.4.C-1. Area of natural landscapes, based on Esri 2023 land cover data, km²

Landscape zone	Aragatsotn	Ararat	Arma-vir	Gegharkunik	Kotayk	Lori	Shirak	Syunik	Tavush	Vayots Dzor
High-altitude snow-covered	39.1	5.9	0.0	40.2	26.2	0.0	7.5	54.5	0.0	20.9
High mountain alpine	146.4	62.6	0.0	380.5	114.8	134.5	152.9	688.8	10.2	278.0
High mountain subalpine	383.5	245.1	0.0	892.1	290.0	407.7	479.4	1021.6	134.1	499.5
Middle mount. meadow steppe	351.3	199.8	0.0	768.9	288.0	735.7	648.7	664.7	294.6	404.3
Middle mountain steppe	611.2	631.7	0.0	943.5	553.7	481.4	482.9	494.4	0.0	636.7
Low mountain, dry steppe	527.8	214.3	272.5	0.0	160.4	0.0	19.0	0.0	0.0	224.1
Low-middle mountain forest	50.1	55.7	0.0	284.5	231.3	1448.1	0.0	854.0	1595.4	106.3
Low-mid. mount. forest shelter belt	0.0	33.7	0.0	53.3	0.0	81.3	0.0	338.2	489.3	0.0
Mountain-valley semidesert	45.1	139.6	189.3	0.0	0.0	0.0	0.0	0.0	0.0	37.0
Submountain semidesert	0.0	0.0	0.0	0.0	0.0	0.0	0.0	15.0	0.0	0.0

Table 2.4.C-2. Area of natural landscapes, based on ESA 2021 land cover data, km²

Landscape zone	Aragatsotn	Ararat	Arma-vir	Gegharkunik	Kotayk	Lori	Shirak	Syunik	Tavush	Vayots Dzor
High-altitude snow-covered	25.6	13.7	0.0	24.8	19.2	0.0	5.1	81.2	0.0	29.6
High mountain alpine	128.2	72.6	0.0	331.2	119.1	63.1	212.4	639.3	16.7	282.8
High mountain subalpine	393.5	271.4	0.0	842.9	287.5	361.7	561.3	919.2	127.2	489.4
Middle mount. meadow steppe	378.0	195.1	0.0	778.4	279.1	699.1	811.6	601.3	274.1	376.5
Middle mountain steppe	478.6	591.4	0.0	915.3	506.6	562.9	457.4	411.9	0.2	604.4
Low mountain, dry steppe	555.8	184.8	232.9	0.0	195.7	0.0	11.2	0.0	0.0	213.2
Low-middle mountain forest	59.0	54.8	0.0	286.9	222.7	1502.0	0.0	836.1	1567.9	102.7
Low-mid. mount. forest sh. belt	0.0	28.6	0.0	63.3	0.0	77.6	0.0	309.6	479.1	0.0
Mountain-valley semidesert	11.6	147.5	186.3	0.0	0.0	0.0	0.0	0.0	0.0	36.1
Sub-mountain semidesert	0.0	0.0	0.0	0.0	0.0	0.0	0.0	14.4	0.0	0.0

According to the Esri land-cover data, the natural area of steppe and meadow-steppe landscapes decreased in all marzes except Vayots Dzor, Tavush, and Ararat (these landscape zones are absent in Armavir); subalpine landscape decreased in Shirak mars; low-mountain dry steppe – in Aragatsotn and Armavir marzes (Figure 2.4.C-2; Table 2.4.C-3). The only noticeable increases in the natural (non-cropland, non-built-up) area of landscape zones are the increase in mountain-valley semidesert area in the Ararat and Armavir marzes and in areas of low mountain, dry steppe in Ararat, driven by a reduction in cropland in these marzes (see Section 2.2.B).

Table 2.4.C-3. Changes in the areas of natural landscapes from 2017 to 2023, % relative to 2017

	Aragatsotn	Ararat	Armavir	Gegharkunik	Kotayk	Lori	Shirak	Syunik	Tavush	Vayots Dzor	Total
Changes, km2											
High-altitude snow-covered	0.01	0.02	0.00	0.00	0.73	0.00	0.00	-0.02	0.00	0.00	0.75
High mountain alpine	-1.34	-0.06	0.00	0.12	-0.03	0.00	-0.01	0.39	0.00	-0.10	-1.03
High mountain subalpine	-1.25	-0.27	0.00	4.27	-0.88	-0.61	-20.75	-4.58	-0.01	-0.13	-24.20
Middle mountain meadow steppe	-50.33	0.25	0.00	-14.64	0.38	-21.47	-131.42	-25.29	-0.10	-0.24	-242.86
Middle mountain steppe	3.15	0.60	0.00	-79.17	-24.57	-85.90	-61.12	-33.06	0.00	-0.45	-280.52
Low and middle mountain forest	-2.17	0.01	0.00	-7.23	5.60	-10.54	0.00	-7.54	-0.74	-0.41	-23.03
Low-mid. mount. forest shelter belt	0.00	-0.09	0.00	-3.13	0.00	-2.25	0.00	1.33	4.63	0.00	0.48
Low mountain, dry steppe	-18.98	9.98	-19.59	0.00	-3.44	0.00	-0.66	0.00	0.00	-1.19	-33.88
Mountain-valley semidesert	-0.36	13.03	20.23	0.00	0.00	0.00	0.00	0.00	0.00	-0.76	32.14
Submountain semidesert	0.00	0.00	0.00	0.00	0.00	0.00	0.00	-0.37	0.00	0.00	-0.37
Share of changed area, relative to 2017, %											
High-altitude snow-covered	0.03	0.39	0.00	0.00	2.88	0.00	0.00	-0.03	0.00	0.00	
High mountain alpine	-0.91	-0.09	0.00	0.03	-0.02	0.00	0.00	0.06	0.00	-0.04	
High mountain subalpine	-0.32	-0.11	0.00	0.48	-0.30	-0.15	-4.15	-0.45	-0.01	-0.03	
Middle mountain meadow steppe	-12.53	0.12	0.00	-1.87	0.13	-2.84	-16.85	-3.67	-0.04	-0.06	
Middle mountain steppe	0.52	0.10	0.00	-7.74	-4.25	-15.14	-11.24	-6.27	0.00	-0.07	
Low and middle mountain forest	-4.16	0.01	0.00	-2.48	2.48	-0.72	0.00	-0.88	-0.05	-0.38	
Low-mid. mount. forest shelter belt	0.00	-0.28	0.00	-5.55	0.00	-2.70	0.00	0.39	0.95	0.00	
Low mountain, dry steppe	-3.47	4.89	-6.71	0.00	-2.10	0.00	-3.36	0.00	0.00	-0.53	
Mountain-valley semidesert	-0.80	10.29	11.97	0.00	0.00	0.00	0.00	0.00	0.00	-2.01	
Submountain semidesert	0.00	0.00	0.00	0.00	0.00	0.00	0.00	-2.43	0.00	0.00	

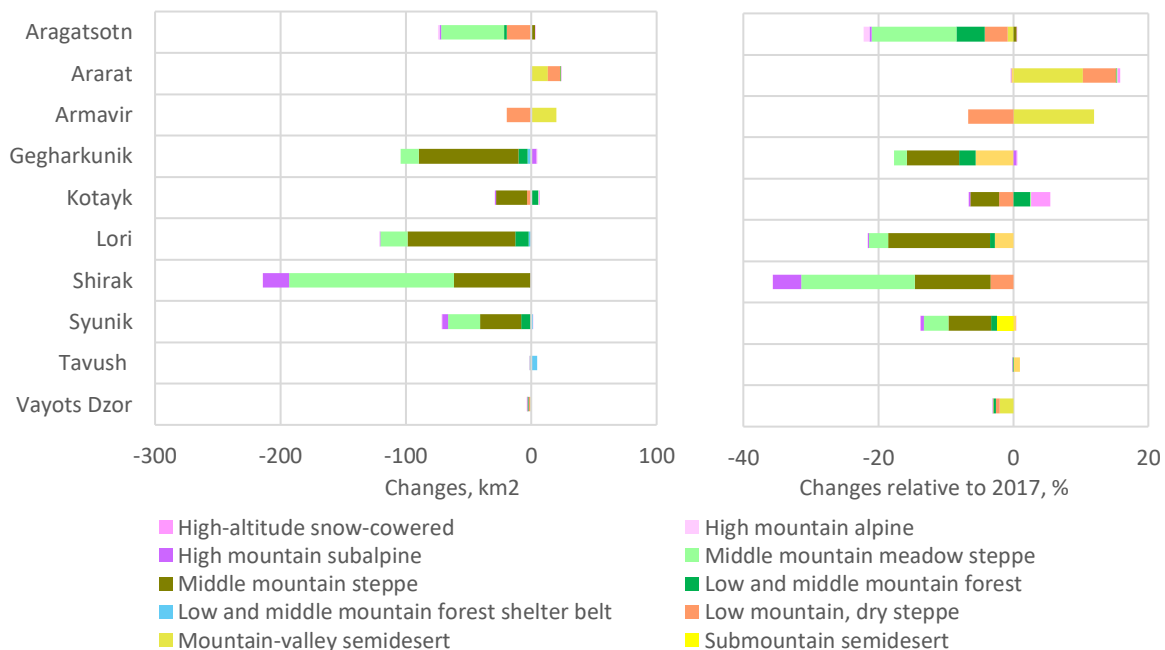

Figure 2.4.C-2. Changes in natural landscape extent from 2017 to 2023, based on Esri data: a) absolute changes, km²; b) share of changed area relative to 2017, %

2.4.D. Assessment of marz importance for conservation of natural landscape diversity in Armenia

To assess the importance of marzes for conserving natural landscapes in Armenia, we used the indicator of the total share of landscape areas located within each marz relative to the total area of that landscape in Armenia. This approach was applied to ensure that the value of rare landscapes is not diminished.

The rankings based on Esri and ESA data are very similar, differing only in the positions of some marzes with similar indicators in the middle of the list. According to the criterion we used, Syunik marz has the greatest value for conserving Armenia’s landscape diversity, because it contains the highest cumulative share of the national extent of all landscape zones. The high summed Syunik value is largely due to the fact that 100% of submountain semidesert zone occurs in Syunik. However, even without it, Syunik still ranks above the other marzes. The least valuable are Shirak, Kotayk, and Armavir marzes (Fig. 2.4.D-1; Tables 2.4.D-1 and 2.4.D-2).

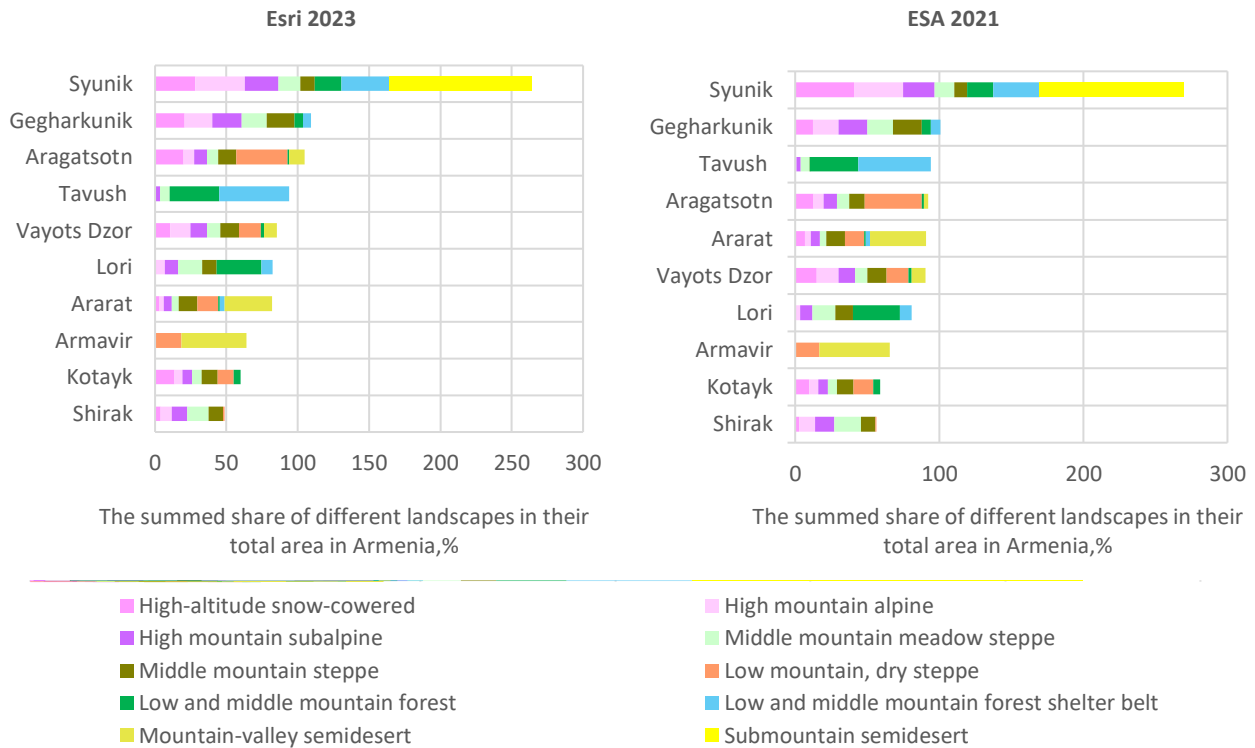

Figure 2.4.D-1. The rankings of marz importance for conservation of natural landscape diversity in Armenia. The total percentage for provinces can exceed 100%.

Table 2.4.D-1. The share of different landscapes in their total area in Armenia according to Esri data, %. The total percentage for provinces can exceed 100%.

	Syunik	Geghar-kunik	Aragats-otn	Tavush	Vayots Dzor	Lori	Ararat	Arma-vir	Kotayk	Shirak
2023										
High-altitude snow-covered	28.05	20.71	20.11	0	10.74	0	3.03	0	13.5	3.85
High mountain alpine	34.99	19.33	7.44	0.52	14.12	6.83	3.18	0	5.83	7.77
High mountain subalpine	23.47	20.49	8.81	3.08	11.47	9.37	5.63	0	6.66	11.01
Middle mountain meadow steppe	15.26	17.65	8.07	6.76	9.28	16.89	4.59	0	6.61	14.89
Middle mountain steppe	10.22	19.51	12.64	0	13.17	9.96	13.06	0	11.45	9.99
Low mountain, dry steppe	0	0	35.94	0	15.26	0	14.59	18.56	10.93	1.3
Low and middle mountain forest	18.46	6.15	1.08	34.49	2.3	31.31	1.2	0	5	0
Low-mid. mountain forest shelter belt	33.97	5.35	0	49.13	0	8.16	3.39	0	0	0
Mountain-valley semidesert	0	0	10.81	0	8.87	0	33.44	45.33	0	0
Sub-mountain semidesert	100	0	0	0	0	0	0	0	0	0
Total share	264.42	109.2	104.9	93.99	85.21	82.51	82.11	63.89	59.98	48.8
2017										
High-altitude snow-covered	28.2	20.8	20.2	0.0	10.8	0.0	3.0	0.0	13.2	3.9
High mountain alpine	35.0	19.3	7.5	0.5	14.1	6.8	3.2	0.0	5.8	7.8
High mountain subalpine	23.4	20.3	8.8	3.1	11.4	9.3	5.6	0.0	6.6	11.4
Middle mountain meadow steppe	15.0	17.0	8.7	6.4	8.8	16.5	4.3	0.0	6.3	17.0
Middle mountain steppe	10.3	20.0	11.9	0.0	12.5	11.1	12.3	0.0	11.3	10.6

Low mountain, dry steppe	0.0	0.0	36.2	0.0	14.9	0.0	13.5	19.4	10.9	1.3
Low and middle mountain forest	18.5	6.3	1.1	34.3	2.3	31.4	1.2	0.0	4.9	0.0
Low-mid. mountain forest shelter belt	33.8	5.7	0.0	48.7	0.0	8.4	3.4	0.0	0.0	0.0
Mountain-valley semidesert	0.0	0.0	11.7	0.0	9.8	0.0	32.7	43.6	0.0	0.0
Sub-mountain semidesert	100.0	0.0	0.0	0.0	0.0	0.0	0.0	0.0	0.0	0.0
Total share	264.3	109.4	106.2	93.0	84.6	83.5	79.3	63.0	58.9	52.0

Table 2.4.D-2. The share of different landscapes in their total area in Armenia according to ESA 2021 data, %. The total percentage for provinces can exceed 100%.

	Syunik	Geghar-kunik	Tavush	Aragats-otn	Ararat	Vayots Dzor	Lori	Armavir	Kotayk	Shirak
High-altitude snow-covered	40.78	12.45	0	12.85	6.88	14.86	0	0	9.63	2.57
High mountain alpine	34.27	17.76	0.9	6.87	3.89	15.16	3.38	0	6.38	11.39
High mountain subalpine	21.61	19.81	2.99	9.25	6.38	11.5	8.5	0	6.76	13.19
Middle mountain meadow steppe	13.69	17.72	6.24	8.61	4.44	8.57	15.91	0	6.35	18.47
Middle mountain steppe	9.1	20.21	0	10.57	13.06	13.35	12.43	0	11.19	10.1
Low mountain, dry steppe	0	0	0	39.88	13.26	15.3	0	16.71	14.04	0.81
Low and middle mountain forest	18.05	6.19	33.85	1.27	1.18	2.22	32.43	0	4.81	0
Low-middle mountain forest shelter belt	32.32	6.6	50	0	2.99	0	8.1	0	0	0
Mountain-valley semidesert	0	0	0	3.04	38.68	9.45	0	48.84	0	0
Submountain semidesert	100	0	0	0	0	0	0	0	0	0
Total share	269.81	100.74	93.97	92.33	90.76	90.4	80.75	65.55	59.16	56.53

From 2017 to 2023, summed value indicators changed by no more than 3% across marzes (Figure 2.4.D-2). The value for Shirak marz declined from 52.0% to 48.8%, primarily due to a decrease in the share of the national meadow-steppe extent conserved there. For Ararat marz, this indicator rose from 79.3% to 82.1% owing to increases in the shares of the forest, steppe, and semidesert zones. For the other marzes, changes in the aggregate indicator were smaller.

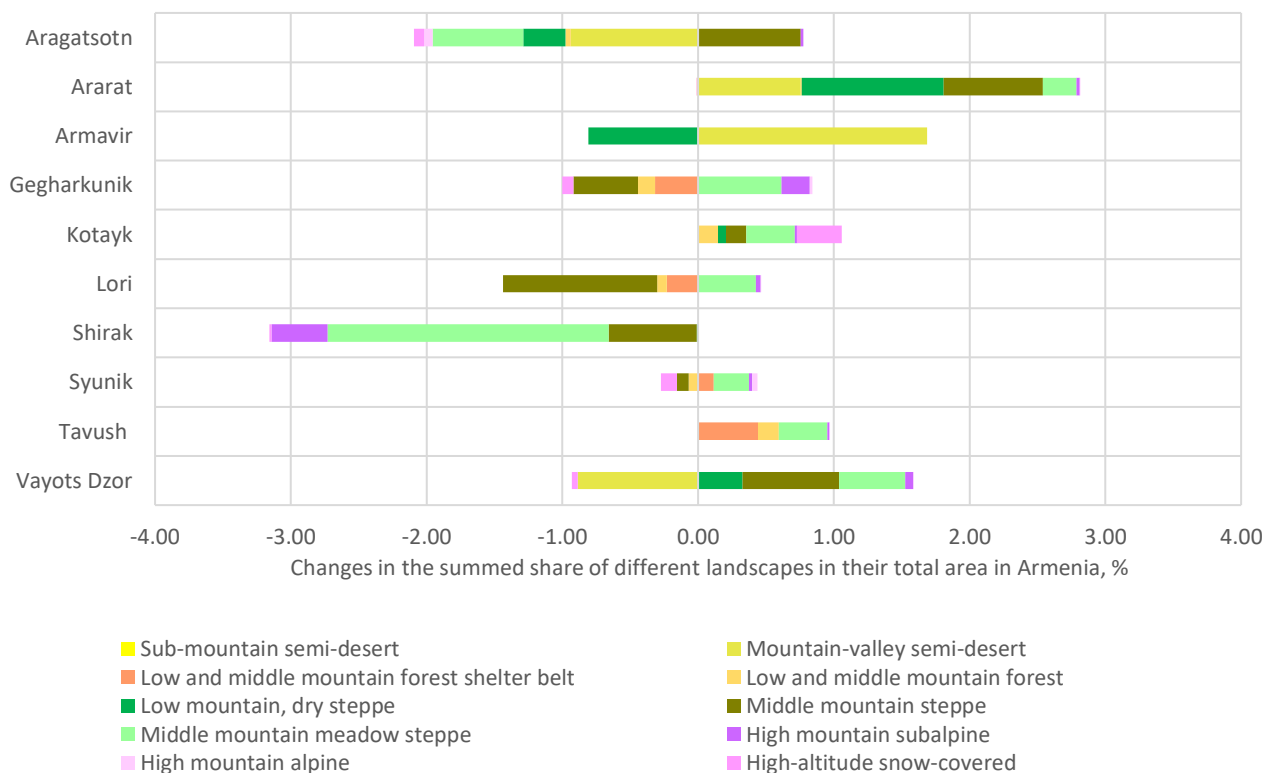

Figure 2.4.D-2. Changes in marz importance for conservation of natural landscape diversity in Armenia from 2017 to 2023.

2.5. Ecosystem extent estimated by landscape-land cover classes (LLCCs)

Publication: Bukvareva E., Grigoryan A., Dubinin M., Kazakov E. Integrating actual land cover data and landscape zone map to assess terrestrial ecosystems in Armenia. *Explora: Environment and Resource* 4996. <https://doi.org/10.36922/eer.4996>

The assessment presented in this section uses the same data sources as Section 2.4: the map of landscape zones of Armenia; Esri land cover data for 2017 and 2023; and ESA 2021 data.

We intersected ten landscape zones with terrestrial land cover classes. The raster landscape map produced for accounting the extent of natural landscapes (Section 3) was spatially intersected with the land cover raster maps through two steps: (i) the pixel values of the land cover map were multiplied by 100, and (ii) these adjusted values were added to the corresponding pixel values of the landscape map, resulting in a unified raster. For example, a final pixel value of 204 indicates that the pixel has a land cover value of two (e.g., trees) and a landscape value of four (e.g., low and middle mountain forest).

The Esri land cover dataset includes four terrestrial natural classes (trees, rangelands, bare ground, and snow/ ice). The ESA dataset includes six terrestrial natural classes (tree cover, shrubland, grassland, moss and lichen, bare and sparse vegetation, and snow and ice). The intersection of ten landscape zones with land cover classes resulted in 60 and 40 combinations, respectively. We termed these combinations as LLCCs since they serve as proxies for ecosystems at this stage of analysis without precisely defining the ecosystems they represent. For simplicity of analysis, LLCCs were grouped into 20 combinations, woody (W) and non-woody (N-W) LLCCs in each landscape zone. We found it appropriate to combine all N-W natural classes (shrubland, grassland, moss and lichen, bare and sparse vegetation, and snow and ice) into one category named N-W LLCCs for several reasons: (i) to reduce the number of analyzed LLCCs for a clearer interpretation of the results, (ii) due to relative imprecision in distinguishing between different non-tree land cover classes, (iii) because of the very small area covered by shrubland, moss and lichen, and snow and ice, and (iv) because the IUCN and EUNIS ecosystem and habitat classifications, 20, 22, 26 including the EUNIS version adapted for Armenia, 34 group shrub vegetation with heathlands and tundra rather than woody vegetation. Thus, the resulting map includes 20 LLCCs obtained by intersecting woody and non-woody areas with 10 landscape zones.

We used LLCCs as a proxy for ecosystems to assess ecosystem rarity and diversity. We estimated the rarity of LLCCs based on their area – LLCCs with the smallest area were considered rare. To assess the importance of provinces for conserving LLCC diversity in Armenia, we calculated the total share of each LLCC area located within each province. Unlike the rarity ranking, which used the share of an LLCC area relative to its total area in Armenia, this method focused on the proportion of an LLCC area within a province compared to its total area in Armenia. This approach was applied to ensure that the value of rare LLCCs is not diminished.

2.5.A. Extent and rarity of LLCC in Armenia

In all landscape zones, non-woody LLCC combinations occupy the predominant area. The only exception is the low and middle mountain forest zone, where woody combinations account for 51% of the natural area (Fig. 2.5.A-1).

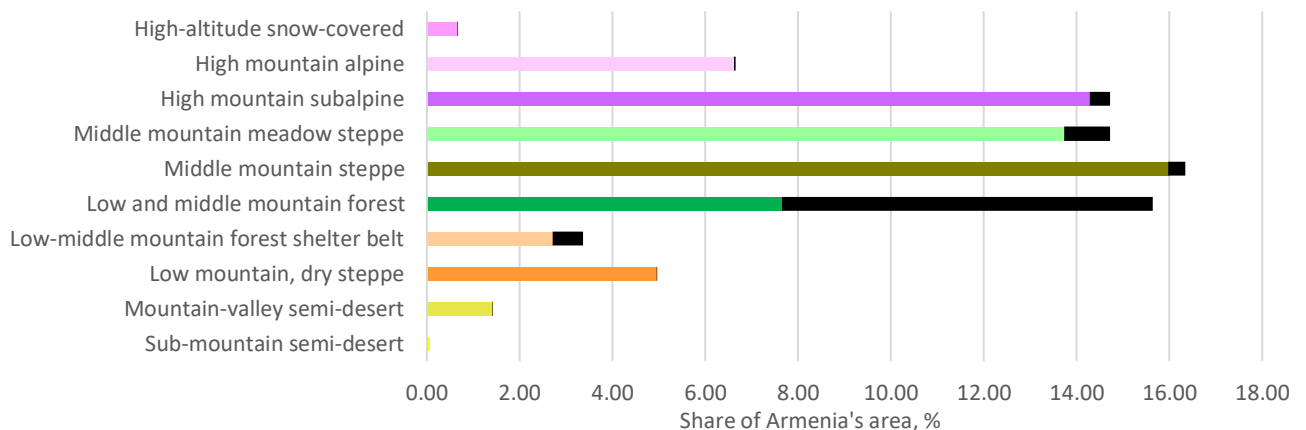

Figure 2.5.A-1. Extent of non-woody LLCC combinations (shown in different colors) and woody combinations (shown in black) across landscape zones in Armenia

The area of the 20 analyzed W LLCCs and N-W LLCCs range from 0.005 km² to 4,700 km². Half of these LLCCs occupy <1% of the country's area and can thus be formally classified as rare (Figure 2.5.A-2). This group includes nearly all woody LLCCs, except those in the low and middle mountain forest, forest shelter belt, and middle mountain meadow steppe.

Among N-W LLCCs, only two, located in the sub-mountain semi-desert and high-altitude zones, were classified as rare. Three LLCCs, N-W ecosystems in subalpine, middle-mountain, and meadow steppe zones, are widespread, each covering between 14% and 16% of the country’s territory. The remaining LLCCs fall between these extremes. Notably, most of the rare LLCCs do not align with the dominant vegetation types of their respective landscape (e.g., trees in high-altitude zones or semi-deserts). These anomalies require careful verification, as they may result from land cover interpretation errors or may belong to anthropogenic areas. Despite the differences in ESA and Esri land cover data, the rarity rankings of LLCCs derived from both sources are very similar.

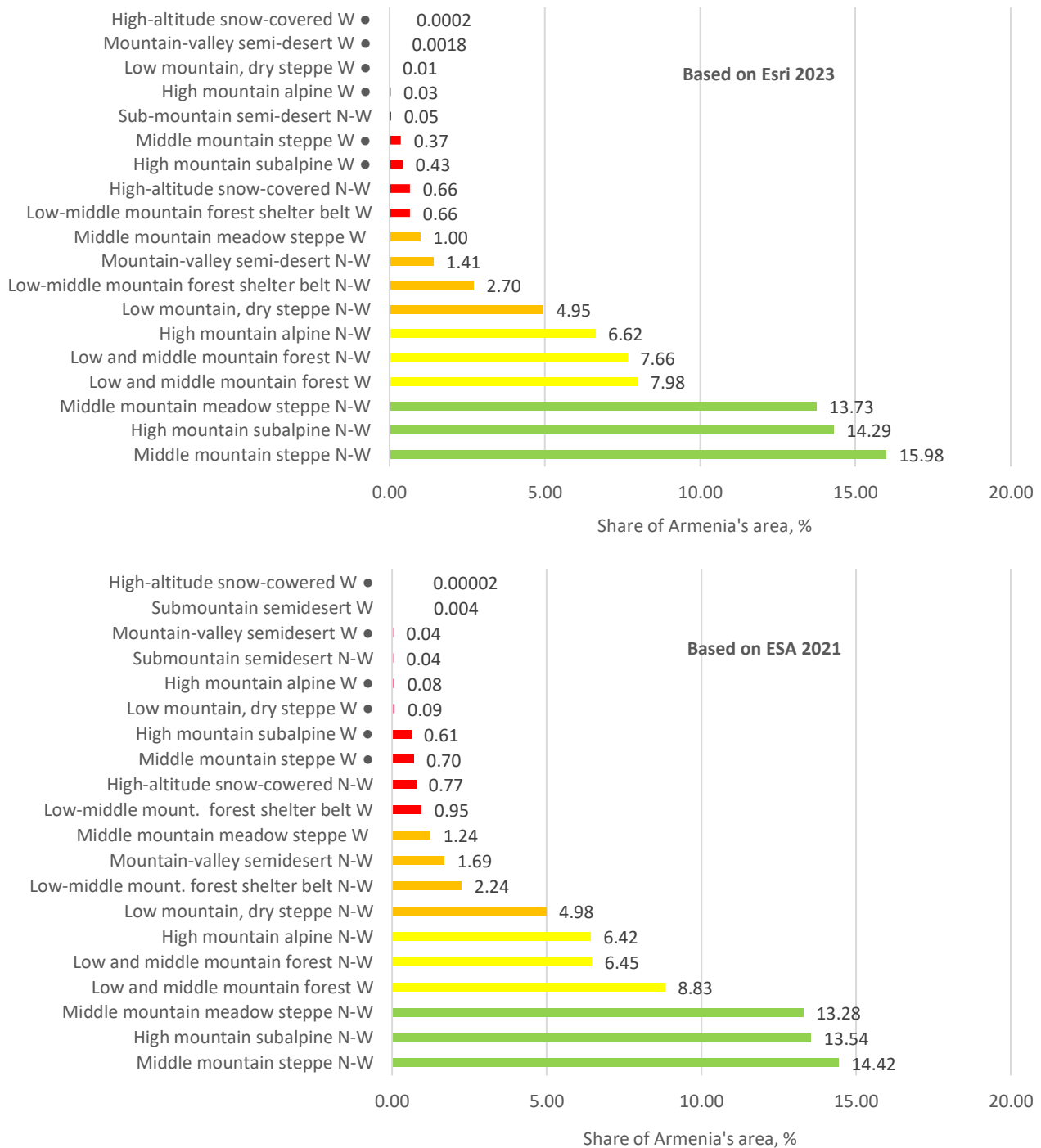

Figure 2.5.A-2. Ranking LLCC types by their area; woody LLCCs are indicated as W, non-woody as N-W; LLCCs occupying no more than 5% of the area of corresponding landscape zone are marked with a '●' symbol

Maps of LLCC rarity, based on these rankings, show a similar distribution pattern (Figure 2.5.A-3). The rarest LLCCs, covering <1% of the country’s area, are distributed in small areas throughout the country, especially in the south, notably in the province of Syunik. Relatively rare LLCCs, occupying 1 – 5% of the country’s area, are primarily found in the Ararat

Valley and its surroundings. These include mountain-valley semi-desert and low-mountain dry steppe LLCCs. Although these LLCCs formally cover a large area, natural vegetation occupies only a small area due to significant anthropogenic transformation. The most widespread LLCCs are located in the central part of the country.

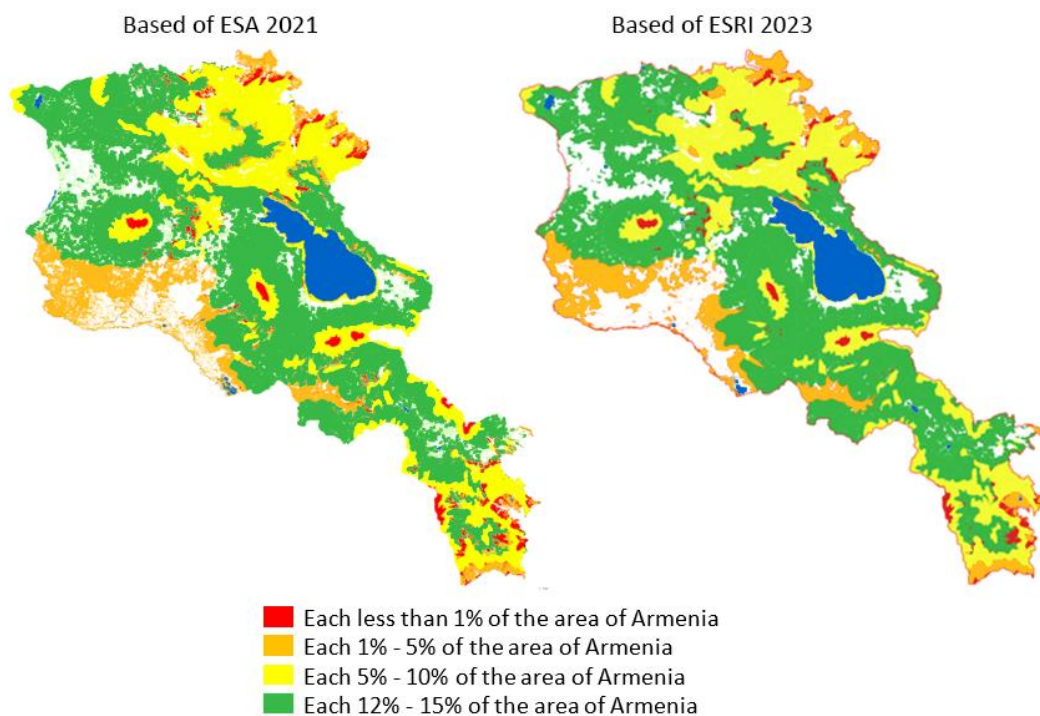

Figure 2.5.A-3. Maps of LLCC rarity based on ESA and Esri land cover datasets

2.5.B. Marz level: LLCC extent and marz importance for conservation of LLCC diversity in Armenia

This section is primarily aimed at analyzing the role of the marzes in conserving Armenia’s ecosystem diversity. Therefore, instead of using absolute extent values in km², we use the indicator of the share of the area of each LLCC that is preserved within the marzes: $S_{im} = LLCC_{im} / LLCC_{ia} * 100\%$, where $LLCC_{im}$ is the area of LLCC i -type in marz m , and $LLCC_{ia}$ is the total area of LLCC i -type in Armenia. This indicator was applied to ensure that the value of rare LLCCs is not diminished.

The pattern of distribution of non-woody LLCCs across marzes generally mirrors the distribution of landscape zones. Moreover, these patterns are very similar based on Esri and ESA data. In contrast, the distribution of woody LLCCs differs significantly both from landscapes zones and between Esri and ESA datasets. According to Esri, marzes Gegharkunik, Kotayk, Lori, and Tavush account for a larger share of woody LLCCs than of landscape zones overall. In contrast, Aragatsotn, Ararat, Shirak, Syunik, and Vyots Dzor account for a smaller share of woody LLCCs (Figure 2.5.B-1, a-c; Appendix 2.5.B-1). According to ESA, marzes Lori, Syunik, and Tavush account for a larger share of woody LLCCs while Aragatsotn, Armavir, Gegharkunik, and Shirak account for a smaller share of woody LLCCs (Figure 2.5.B-1, d-f; Appendix 2.5.B-1).

Marked discrepancies appear when rare LLCCs are concentrated entirely within a single marz—for instance, nearly 100% of woody LLCCs in the high-altitude snow-covered zone of Gegharkunik according to Esri (Fig. 2.5.B-1 c), versus nearly 100% of the same LLCC type in Syunik according to ESA (Fig. 2.5.B-1 f). These patterns are most likely the result of land-cover misclassifications affecting different marzes in the two datasets. A similar inconsistency is observed in the submountain semi-desert zone, where ESA records 100% of woody LLCC in this zone in Syunik (Fig. 2.5.B-1 f), while Esri reports none. Such differences reflect the different methodologies of image interpretation applied in the ESA and Esri datasets (see Section 2.1.A). Overall, the most significant inconsistencies are associated with the rarest LLCCs—woody LLCCs in general, and especially their rarest variants in high-altitude and semi-desert zones—some of which may represent artifacts of land-cover classification rather than actual distribution patterns.

The cumulative value of index S_{im} indicates the overall contribution of a marz to the conservation of LLCC diversity in Armenia. As shown in Figure 2.5.B-1, the contribution of the marzes to the conservation of non-woody LLCCs is similar to their contribution to the conservation of natural landscapes as a whole, whereas their role in conserving woody LLCCs follows a somewhat different pattern.

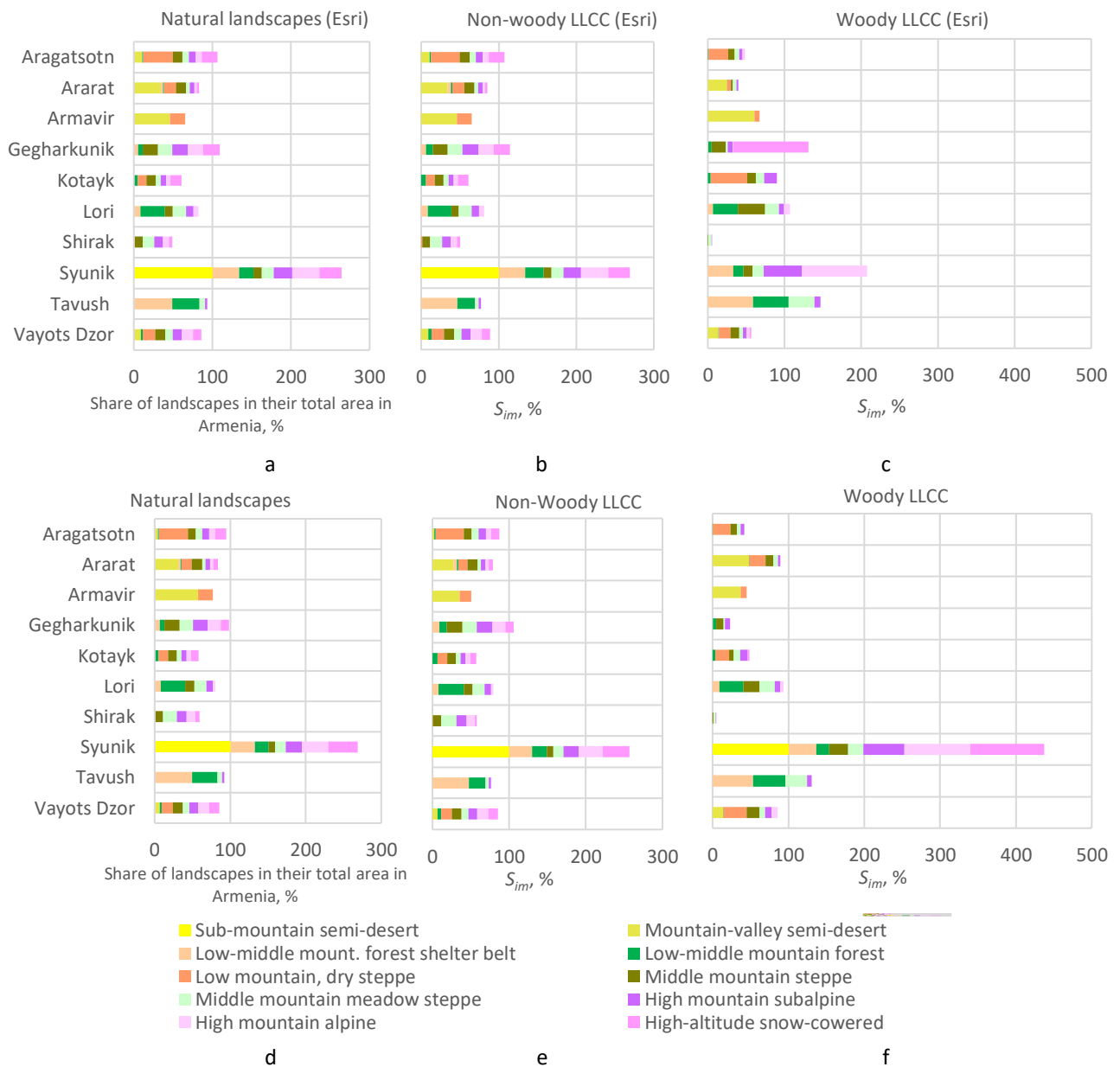

Figure 2.5.B-1. The share of the area of natural landscapes and LLCCs in their total area in Armenia, %: a-c) Based on Esri data; d-f) Based on ESA data. The scales have been made uniform for easier comparison of the data.

Based on the rankings of overall marz contribution to the conservation of all LLCC types (the sum of S_i indices for each marz) derived from the Esri and ESA datasets, only the top-ranked province (Syunik) and the lowest-ranked province (Shirak) remain consistent (Figure 2.5.B-2 a,b; Appendix 2.5.B-2). The positions of other marzes vary within the rankings. When accounting all LLCC types, the rankings are largely influenced by the rarest LLCCs, which may be errors in the land cover datasets. For example, Syunik province ranks exceptionally high based on ESA data because almost all pixels of three rare LLCCs (woody areas in high-altitude snowy and alpine zones and sub-mountain semi-desert) are concentrated there. This pattern is not observed in Esri data. Conversely, Gegharkunik province ranks second in the Esri-based ranking because almost all woody pixels in the high-altitude snowy zone are concentrated there. If the rarest LLCCs, occupying no more than 5% of the landscape zone’s area (marked with a “●” symbol in Figure 2.5.A-2), are excluded from the calculations, the province rankings based on Esri and ESA data become more similar (Figure 2.5.B-2 c,d; Appendix 2.5.B-2). However, some provinces with similar indicators occupy different positions in the middle of the list.

The contribution of marzes Tavush, Syunik, and Lori to the conservation of LLCC diversity differs of their importance for landscape diversity (Section 2.4). Moreover, these differences are revealed in both the Esri and ESA data, indicating that they are not the result of land-cover misclassifications (Figure 2.5.B-3). These three marzes stand out from the others because they preserve most of the woody LLCCs (Figure 2.5.B-4), which are generally rarer in Armenia than the non-woody ones.

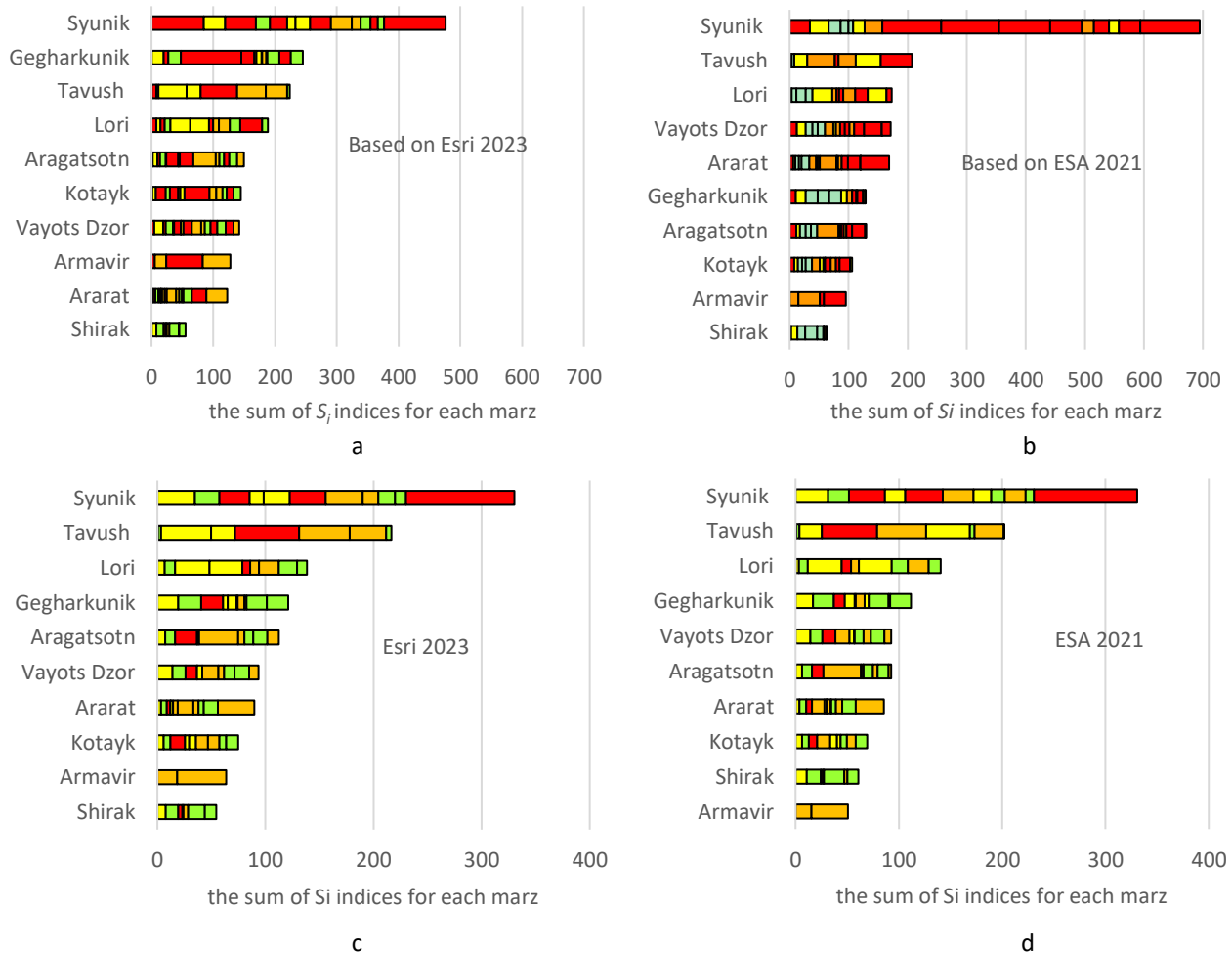

Figure 2.5.B-2. The rankings of marz cumulative importance for conserving LLCC diversity in Armenia (the sum of S_i indices for each marz): a,b) all LLCCs; b,c) excluding LLCCs that occupy no more than 5% of the landscape zone's area. The LLCCs are shown in red, the less rare ones in orange, the relatively common in yellow, and the most common in green, as in the figure 2.5.A-2. The total percentage for provinces can exceed 100%.

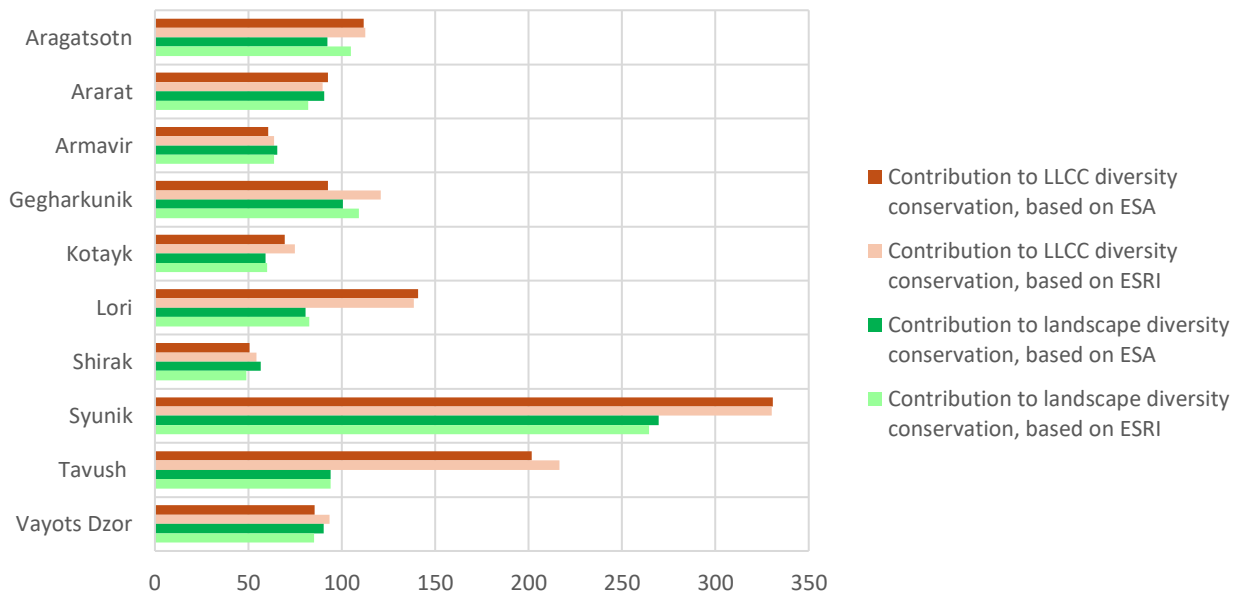

Figure 2.5.B-3. Marz contribution to conservation of LLCC and landscape diversity in Armenia, based on Esri and ESA data

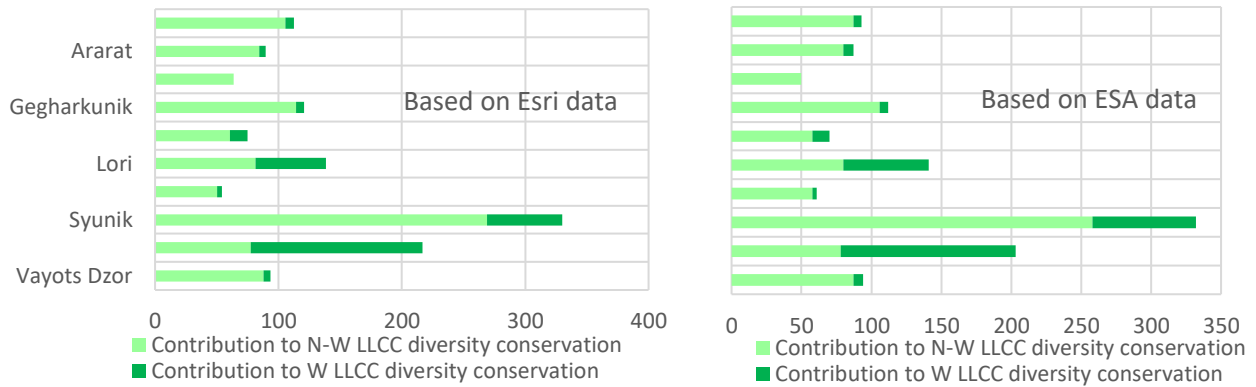

Figure 2.5.B-4. Marz’ contributions to conservation of non woody and woody LLCC diversity, based on Esri and ESA data.

2.5.C. Changes in LLCC extent and in marz importance for the conservation of LLCC diversity in Armenia

Land cover changes recorded by Esri data from 2017 to 2023 have resulted in changes in the area of natural landscapes and LLCC extent (Figure 2.5.C-1). The data on LLCC changes provides the following additional information compared to the data on landscape changes (Section 2.4.B):

- The area of woody LLCCs has decreased more significantly than that of non woody LLCCs within the middle-mountain meadow steppe;
- The total reduction in the area of mountain forest landscapes is driven by opposing changes in woody and N-W LLCCs, specifically, a decrease in woody LLCCs and an increase in N-W LLCCs;
- The total area of the forest shelter belt has remained unchanged, although the woody LLCCs within it have decreased.

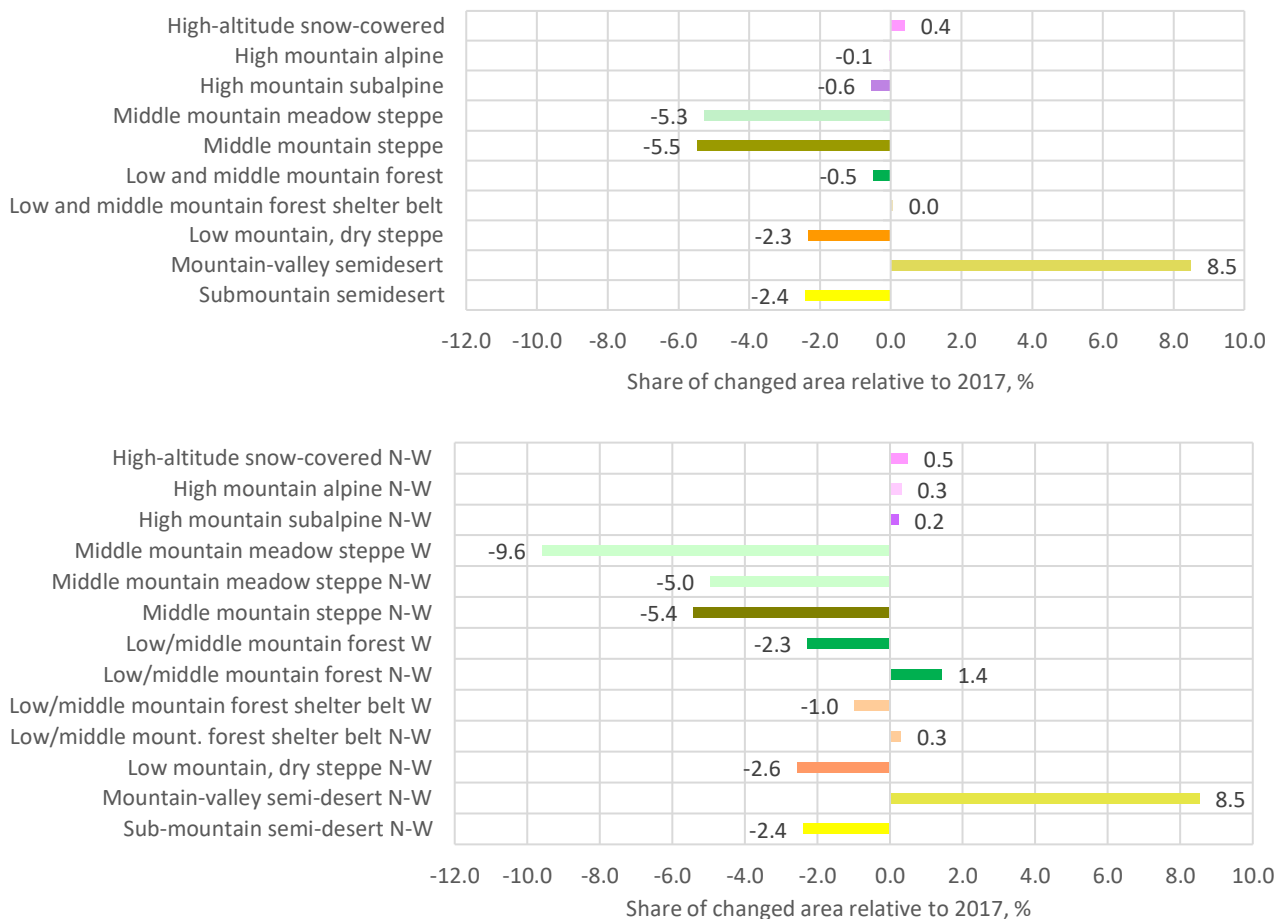

Figure 2.5.C-1. Changes in the extent of natural landscapes (a) and LLCC (b) from 2017 to 2023 based on Esri data

For the assessment of changes in provincial importance (Figure 2.5.C-2), the data on LLCCs provides the following additional information: (i) the importance of the Syunik province for conserving LLCCs has decreased, even though it has remained unchanged with respect to landscapes and (ii) the importance of the Tavush province for conserving LLCCs has grown significantly more than it has for landscapes.

Preliminary conclusions for organizing ecosystem accounting from the LLCC exercise are as follows:

- The LLCC map makes it possible to identify rare LLCCs, however, rare LLCCs with a very small area must be carefully validated to exclude land cover classification errors;
- The rarer the LLCCs are, the greater the differences in estimates between the land-cover datasets. The same can be expected when accounting for real rare ecosystems with small areas;
- LLCC mapping provides additional information compared to the data on landscape extent.

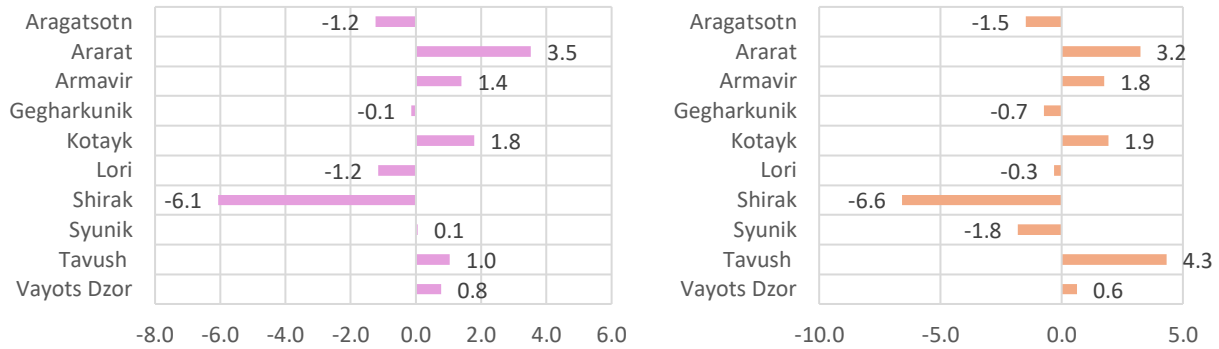

Figure 2.5.C-2. Changes in marz importance for conservation of diversity of natural landscapes (a) and LLCC (b) in Armenia from 2017 to 2023 based on Esri data

2.6. Ecosystem extent in protected areas

2.6.A. Extent of protected areas in Armenia

In accordance with Decree N 1059-Ս (25.09.2014) of the Government of the Republic of Armenia¹³, the PAs in 2014 were as follows:

- 3 state reserves ("Khosrov Forest", "Shikahogh" and "Erebuni"), which occupy an area of 35,439.6 hectares or 1.19% of the total area of Armenia,
- 4 national parks ("Sevan", "Dilijan", "Lake Arpi" and "Arevik"), which occupy an area of 236,802.1 hectares or 7.96% of the total area of Armenia,
- 232 natural monuments,
- 27 state sanctuaries, which occupy an area of 114,812.7 hectares or 3.95% of the total area of Armenia.

The total area of state reserves, sanctuaries, and national parks was 387,054.4 hectares, which accounted for 13.1% of Armenia's total territory.

Table 1. PAs areas in 2014 according to the Ministry of Environment of Armenia

PA	Area, ha
STATE RESERVES	
Khosrov Forest	23 213.5
Shikahogh	12 137.1
Erebuni	89.0
NATIONAL PARKS	
Sevan	147 455.0
Dilijan	33 765.0
Lake Arpi	21 179.3
Arevik	34 401.8
NATURAL SANCTUARIES	
Akhnabad	25.0
Arjatkhlenu	40.0
Juniper sparse forest	3 312.0
Gyulagarak	2 576.0
Herher sparse forest	6 139.0
Jermuk Forest	3 865.0
Sosu Park	64.2
Aragats Alpine	300.0
Banks pine	4.0
Goravan sand dunes	95.99
Caucasian rosehip	1 000.0
Arzakan-Meghradzor	13 532.0
Gandzakar	6 813.0
Getik	5 728.0
Ijevan	5 908.0
Margahovitti	3 368.0
Yeghegnadzor	4 200.0
Goris	1850.0
Red worm	219.85
Boghakar	2 728.0
Black Lake	240.0
Deep wound	50.28
Hanqavan Hydrological	5 169.04
Jermuk Hydrological	17 371.0
Zangezur	25 870.64
Zikatar	150.0
Khustup	6946.74

¹³ <https://www.arlis.am/hy/acts/93166>

2.6.B. Ecosystem extent in PAs based on Esri land cover data

At the present stage, we do not have access to official data covering all Armenian PAs for the period after 2014, official digitized maps of PA boundaries, or land cover data specifically refined for the territory of Armenia. Therefore, the following analyses are based on the available digital PA map referenced below and the global Esri land cover dataset.

The use of the Esri land cover dataset for relatively small PA areas leads to significant errors in area estimation. In the examples below, we demonstrate only the type of analysis that can, in principle, be conducted for ecosystem accounting of PAs based on land cover data. **All estimates are of methodological value only and should be refined using official PA boundaries and land cover data provided by the PAs.**

This example of accounting is based on the PA map provided by Acopian Center for the Environment, American University of Armenia¹⁴ (Figure 2.6.B-1), the vegetation map prepared in the framework of our project (Section 2.3), and Esri land cover data from 2017 and 2023.

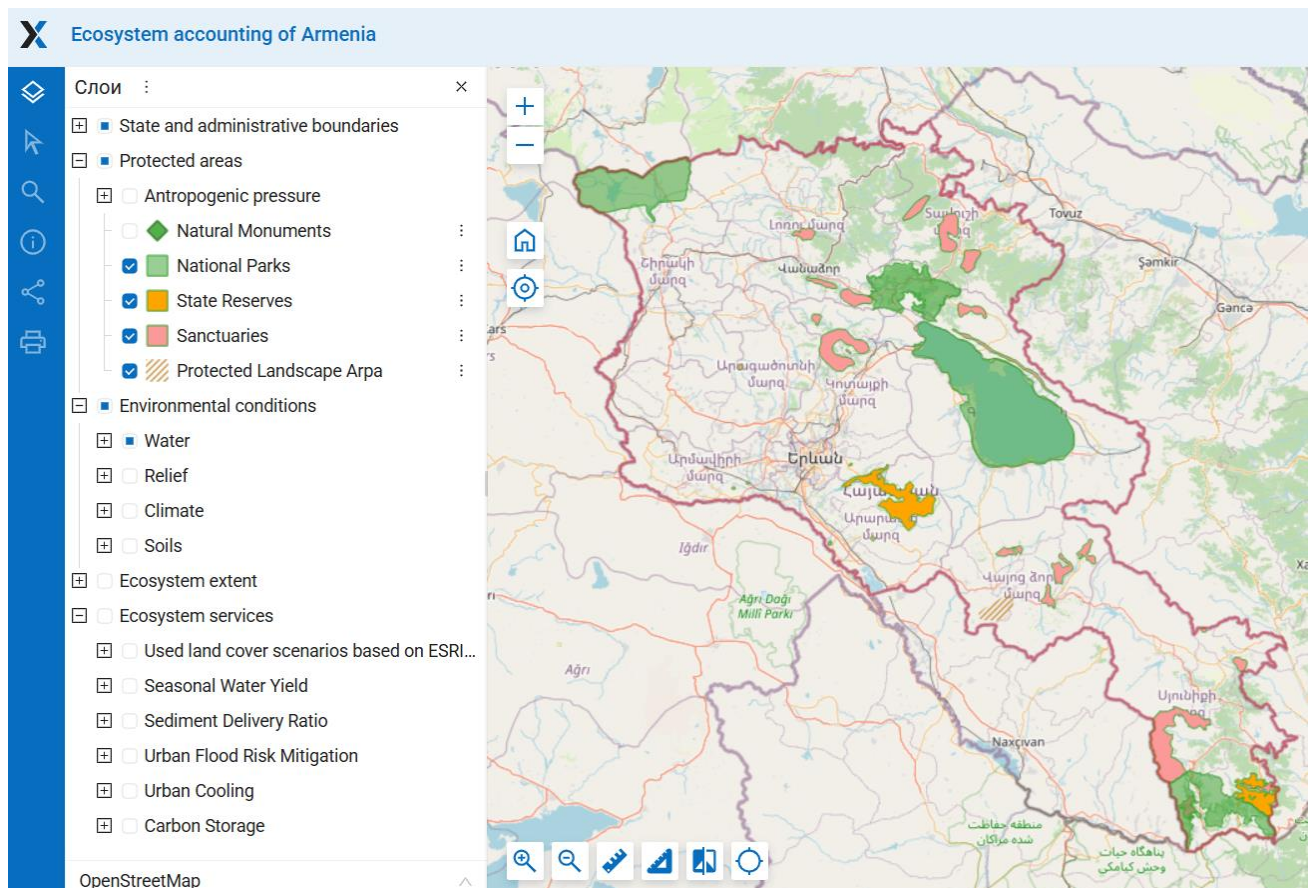

Figure 2.6.B-1. The map of protected areas of Armenia. For details see project WEB GIS (<https://bccarmenia.nextgis.com/>), section “Protected areas” (the location of the Goravan Sands Sanctuary needs to be clarified)

The extent of land-cover classes in the PAs indicates the area of woody vegetation and the degree of human-induced transformation (Figure 2.6.B-2; Table 2.6.B-1). According to Esri (2023), the entire area of the Ararat Vordan Karmir Sanctuary is occupied by croplands and built-up areas. Human-modified territories cover about half of the Goravan Sands and Goris Sanctuaries. The areas of Sevan and Arpi Lake National Parks, as well as the Khor Virap Sanctuary, are also significantly transformed. Forest vegetation occupies most of the territory of the Shikahogh Reserve and the Dilijan National Park, as well as the Gandzakar–Upper Aghdan, Ijevan, Pine of Gyulagarak, and Zikatar Sanctuaries. By contrast, forest is almost absent in the Erebuni Reserve, Arpi Lake National Park, and in 11 other sanctuaries.

¹⁴ <https://ace.aua.am/>

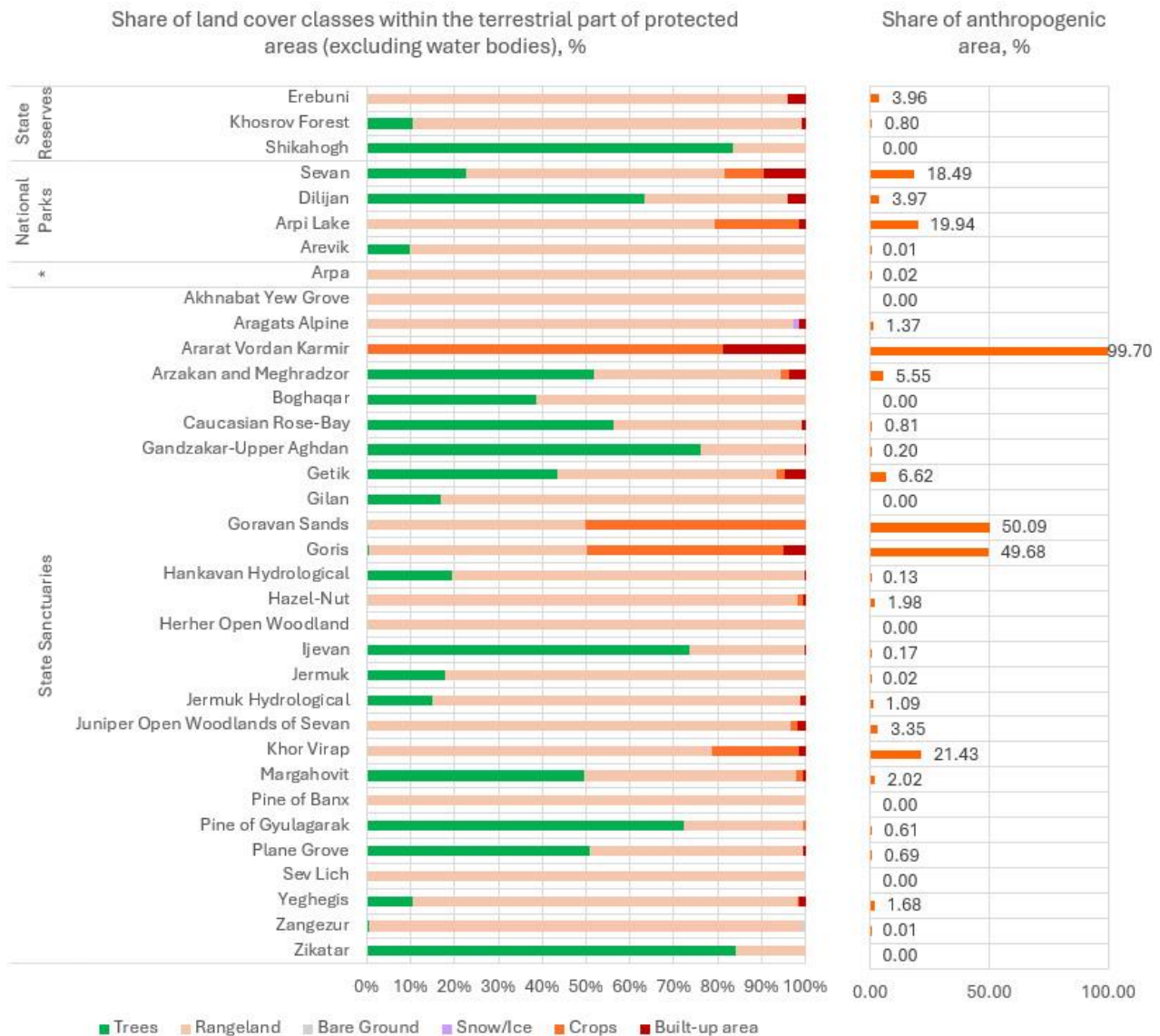

Figure 2.6.B-2. The share of areas of land cover classes and anthropogenic areas, %. *Arpa is protected landscape

All vegetation zones are represented in the PAs. The area of some PAs is entirely covered by vegetation of a single zone, for example: Goravan Sands – desert; Erebuni, Ararat, and Khor Virap – semi-desert; Hazel Nut – broadleaf woodlands; Gandzakar-Upper Aghdan, Goris, Hankavan Hydrological, Pine of Gyulagarak, Plane Grove – forest zone; Akhnabat Yew Grove, Pine of Banx, Sev Lich – subalpine meadows; Aragats Alpine – alpine meadows (Figure 2.6.B-3).

Overall, vegetation zones are unevenly represented in the PAs. The forest zone occupies the largest area within the PAs—about 1,400 km². Other zones are much smaller, ranging from 500 km² of subalpine zone to 46 km² of marshes (Figure 2.6.B-4a). The shares of the zones’ areas preserved in the PAs are also highly unequal. 26% and 32% of the forest and juniper zones are preserved in the PAs while for the semi-desert, steppe, and open woodland zones this share is less than 10% (Figure 2.6.B-4b). The desert zone is not indicative in this analysis, as it is represented by only one small unique site).

Between the total area of a vegetation zone and the share of its area preserved in the PAs, a weak, non-significant tendency towards a negative relationship between the total zone area of a vegetation zone and its representation in the PAs: the larger the total area of a zone, the lower its representation in the PAs (Figure 2.6.B-5). Even from this weak trend it is possible to distinguish zones that are better represented in the PAs, lying above the trend line (juniper, forest), and underrepresented zones, lying below the trend line (semi-desert, broadleaf woodland).



Figure 2.6.B-3. The share of area of vegetation zones in PAs, %

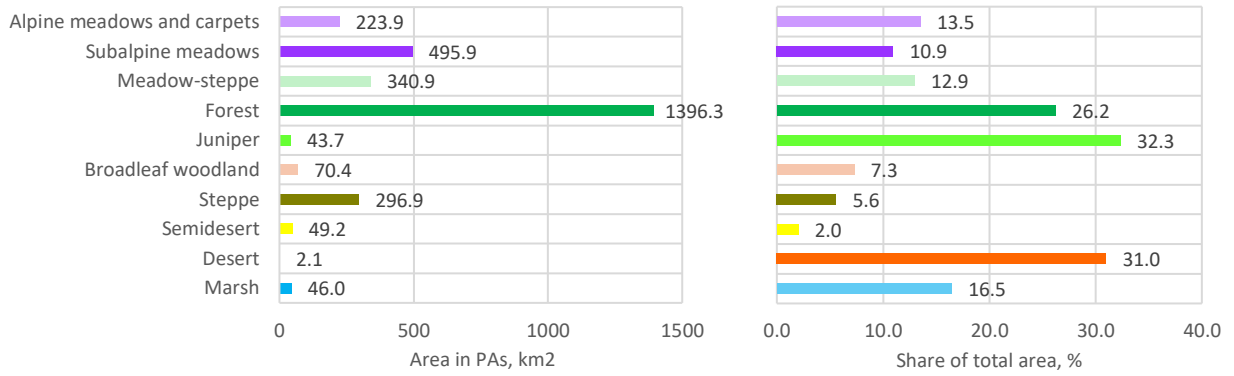

Figure 2.6.B-4. Area and the share of the natural area of a vegetation zone located in the PAs

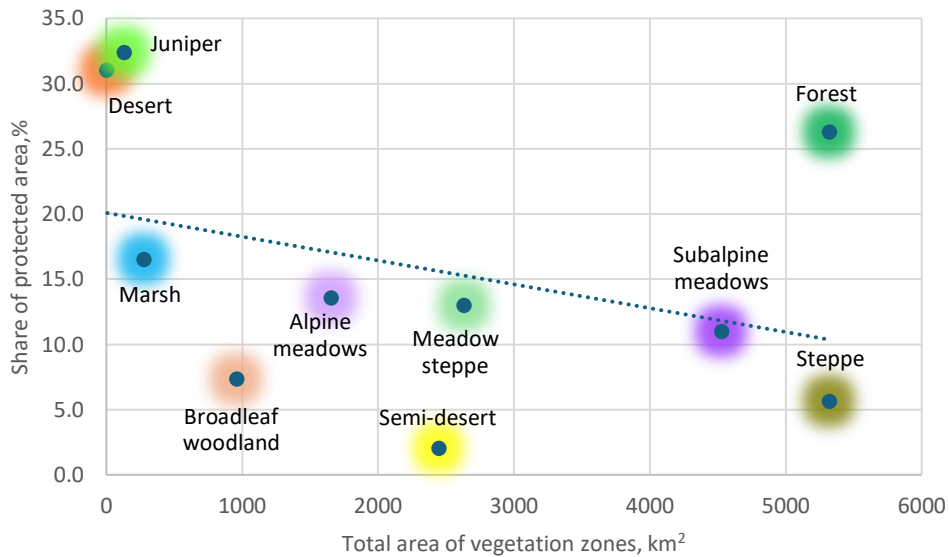

Figure 2.6.B-5. A weak, non-significant tendency towards a negative relationship between the total area of a vegetation zone and its representation in the PAs.

Table 2.6.B-1. Area of land cover classes in PAs, ha (* the total area of PAs shown on the map used may differ from the official data, as the PA boundaries on the map require further clarification)

PA type	PA	Trees	Rangeland	Bare Ground	Snow/Ice	Water and flood. veg.	Crops	Built-up area	Total area of PA*
State Reserves	Erebuni	0	84.84	0	0	0	0	3.5	88.30
	Khosrov Forest	2404.91	20231.17	31.76	0	0.51	5.33	176.63	22868.59
	Shikahogh	9854.31	1937.14	0	0	0	0	0	11810.26
National Parks	Sevan	5525.1	14346.23	13.23	0	126863.3	2173.48	2336.68	151374.99
	Dilijan	24757.79	12862.58	0	0	5.21	11.41	1546.26	39214.50
	Arpi Lake	186.33	43922.3	8.64	0	2123.82	10719.45	810.1	57828.90
	Arevik	4158.48	37530.44	36.28	1.25	3.11	0	5.12	41852.62
Protected landscape	Arpa	1.49	8148.12	1.01	0	0	0	1.7	8158.56
State Sanctuaries	Akhnabat Yew Grove	0	24.85	0	0	0	0	0	24.86
	Aragats Alpine	0	276.72	0.17	4.1	15.67	0	4.11	301.07
	Ararat Vordan Karmir	0	0.37	0	0	0	166.63	38.36	205.60
	Arzakan and Meghradzor	7503.25	6181.2	3.39	0	7.27	285.16	521.26	14518.08
	Boghaqar	1112.76	1757.96	0	0	0	0	0	2872.27
	Caucasian Rose-Bay	1037.93	794.25	0	0	0	0	15.02	1848.58
	Gandzakar-Upper Aghdan	2973.96	925.74	0	0	0	0.07	7.73	3910.26
	Getik	1354.88	1559.37	0.03	0	1.65	58.24	148.68	3124.67
Gilan	48.48	238.6	0.23	0	0	0	0	287.41	

Goravan Sands	0	106.47	0	0	0	106.93	0	213.47
Goris	11.93	934.73	0	0	0	847.96	96.39	1901.05
Hankavan Hydrological	191.05	783.42	0	0	0	0	1.3	976.53
Hazel-Nut	0	40.73	0	0	0	0.58	0.24	41.48
Herher Open Woodland	7.17	2047.41	6.58	0	35.85	0	0	2098.67
Ijevan	5725.75	2048.54	0	0	0	5.7	7.29	7793.64
Jermuk	726.01	3336.61	0	0	0	0.94	0	4066.48
Jermuk Hydrological	388.69	2163.31	0	0	0.05	0	28.1	2581.86
Juniper Open Woodlands of Sevan	8.9	3764.79	21.6	0	0.2	60.96	70.75	3930.40
Khor Virap	0.01	124.8	0	0	0.28	31.71	2.45	159.37
Margahovit	2285.4	2222.63	0	0.14	0	69.85	23.13	4604.38
Pine of Banx	0	4.62	0	0	0	0	0	4.61
Pine of Gyulagarak	1768.24	661.81	0	0	0	14.27	0.61	2446.95
Plane Grove	1098.25	1049.34	0	0	0	1.43	13.58	2174.57
Sev Lich	0	150.56	0.47	0	89.14	0	0	240.32
Yeghegis	230.75	1927.08	0.45	0	0	0.52	36.32	2196.95
Zangezur	127.06	24156.19	241.24	3.54	33.9	2.03	0	24711.29
Zikatar	2691.57	504.37	0	0	0	0	0	3198.61

Table 2.6.B-2. Area of vegetation zones in PAs, ha (*the total area of PAs shown on PA map used may differ from the official data, as the PA boundaries on the map require further clarification)

PA type	PA	Alpine meadows and carpets	Sub-alpine meadows	Meadow-steppe	Forest	Juniper	Broad-leaf woodland	Steppe	Semi-desert and desert	Mars h	Total terrestrial area of PA*
State Reserves	Erebuni	0	0	0	0	0	0	0	88.34	0	88.34
	Khosrov Forest	0	268.64	0	8533.69	0	14.72	12399.13	1626.9	3.58	22846.66
	Shikahogh	0	405.25	0	11224.97	0	0	0	0	0	11630.22
National Parks	Sevan	0	0	16.03	20957.52	0	0	5204.09	0	0	26177.64
	Dilijan	0	6667.11	15.37	30799.09	0	0	1701.68	0	0	39183.25
	Arpi Lake	2375.3	17575.65	32567.5	0	0	0	40.31	0	4514.4	57073.13
	Arevik	4371.3	6231.62	0	23943.92	0	5172.4	0	1651.39	0	41370.6
Protected landscape	Arpa	0	490.08	0	73.14	17.23	0	6997.61	574.26	0	8152.32
State Sanctuaries	Akhnabat Yew Grove	0	24.85	0	0	0	0	0	0	0	24.85
	Aragats Alpine	300.8	0	0	0	0	0	0	0	0	300.77
	Ararat Vordan Karmir	0	0	0	0	0	0	0	205.36	0	205.36
	Arzakan and Meghradzor	1.87	5171.99	699.07	8547.13	0	0	0	0	86.52	14506.58
	Boghaqar	0.32	600.73	0	2269.67	0	0	0	0	0	2870.72
	Caucasian Rose-Bay	0	235.19	0	1051.5	0	560.51	0	0	0	1847.2
	Gandzakar-Upper Aghdan	0	0	0	3907.5	0	0	0	0	0	3907.5
	Getik	0	1057.62	491.27	1573.96	0	0	0	0	0	3122.85
	Gilan	0	0	0	187.18	0	0	87.72	11.24	0	286.14
	Goravan Sands	0	0	0	0	0	0	0	213.4	0	213.4
	Goris	0	0	0	1900.32	0	0	0	0	0	1900.32
	Hankavan Hydrological	0	0	0	975.77	0	0	0	0	0	975.77
	Hazel-Nut	0	0	0	0	0	41.55	0	0	0	41.55
	Herher Open Woodland	0	0	0	177.97	938.57	0	388.05	592.42	0	2097.01
	Ijevan	0	0	0	6581.18	0	1206.1	0	0	0	7787.28
	Jermuk	0	0	164.7	1896.6	1932.9	0	69.29	0	0	4063.56
	Jermuk Hydrological	0	351.27	136.5	2092.38	0	0	0	0	0	2580.15
	Juniper Open Woodlands of Sevan	0	0	0	298.17	861.8	0	2767.2	0	0	3927.2
	Khor Virap	0	0	0	0	0	0	0	159.25	0	159.25
	Margahovit	0	2440.85	0	2160.31	0	0	0	0	0	4601.16
	Pine of Banx	0	4.62	0	0	0	0	0	0	0	4.62
	Pine of Gyulagarak	0	2.62	0	2442.31	0	0	0	0	0	2444.93
	Plane Grove	0	0	0	2160.46	0	0	0	0	0	2160.46
Sev Lich	0.07	240.1	0	0	0	0	0	0	0	240.17	
Yeghegis	0	0	0	1527.23	619.0	0	37.75	11.1	0	2195.12	
Zangezur	15340.9	7825.73	0	1148.02	0	45.62	0	0	0	24360.19	
Zikatar	0	0	0	3195.94	0	0	0	0	0	3195.94	

2.6.C. Changes in the areas of land cover classes in state reserves and national parks

According to Esri, between 2017 and 2023 the most notable changes occurred in Arpi Lake National Park, where the area of croplands increased by more than half, and in the Erebuni Reserve, where it decreased by one third. In the Arevik Reserve, the forest area decreased by 18% (Figure 2.6.C-1).

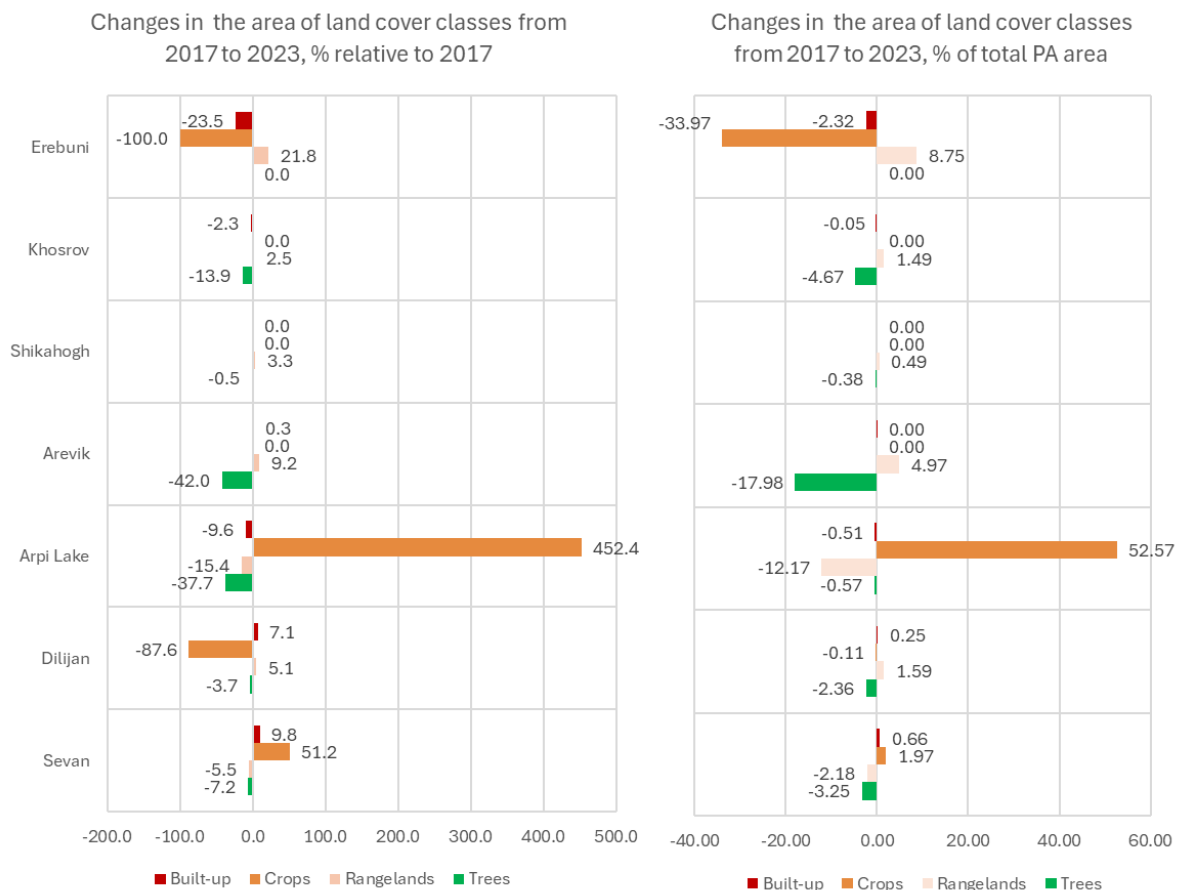

Figure 2.6.C-1. Changes in the area of land cover classes within PAs

2.6.D. Distance from natural monuments to anthropogenic areas and roads

As an example of assessing anthropogenic threats to 'point' ecosystems and natural objects of very small area, distances were measured between the natural monuments (the map provided by Interactive Forest Atlas of Armenia¹⁵ (Figure 2.6.D-1), and anthropogenic areas (built-up areas and croplands according to the Esri 2023 land cover data), roads including main roads and all other roads including trails from the dataset of Interactive Forest Atlas of Armenia, and population polygons with more than 100 residents based on the Kontur Population Dataset¹⁶ (Figures 2.6.D-2, 2.6.D-3).

This example shows that even minor errors in land cover classification—amounting to just a few pixels—can significantly distort the calculated distances to natural monuments. Therefore, to obtain reliable results, it is essential to use land cover data specifically refined for Armenia. Unfortunately, at this stage the lack of an officially approved digital map of PA boundaries, combined with errors in the Esri land-cover data, prevents accurate accounting of ecosystem extent within PAs. For PAs with small areas, even minor land-cover errors can significantly distort the actual proportions of different ecosystem types. Moreover, the misclassification of anthropogenic areas where none exist leads to inaccurate assessments of threats to natural ecosystems and natural monuments. For instance, the misclassification of cropland and built-up areas in the high-mountain zone of the Gegham Ridge in the land-cover data artificially reduced the estimated distance between natural monuments and anthropogenic territories (2.6.D-4).

¹⁵ <https://forestatlas.am/>

¹⁶ <https://www.kontur.io/datasets/population-dataset/>

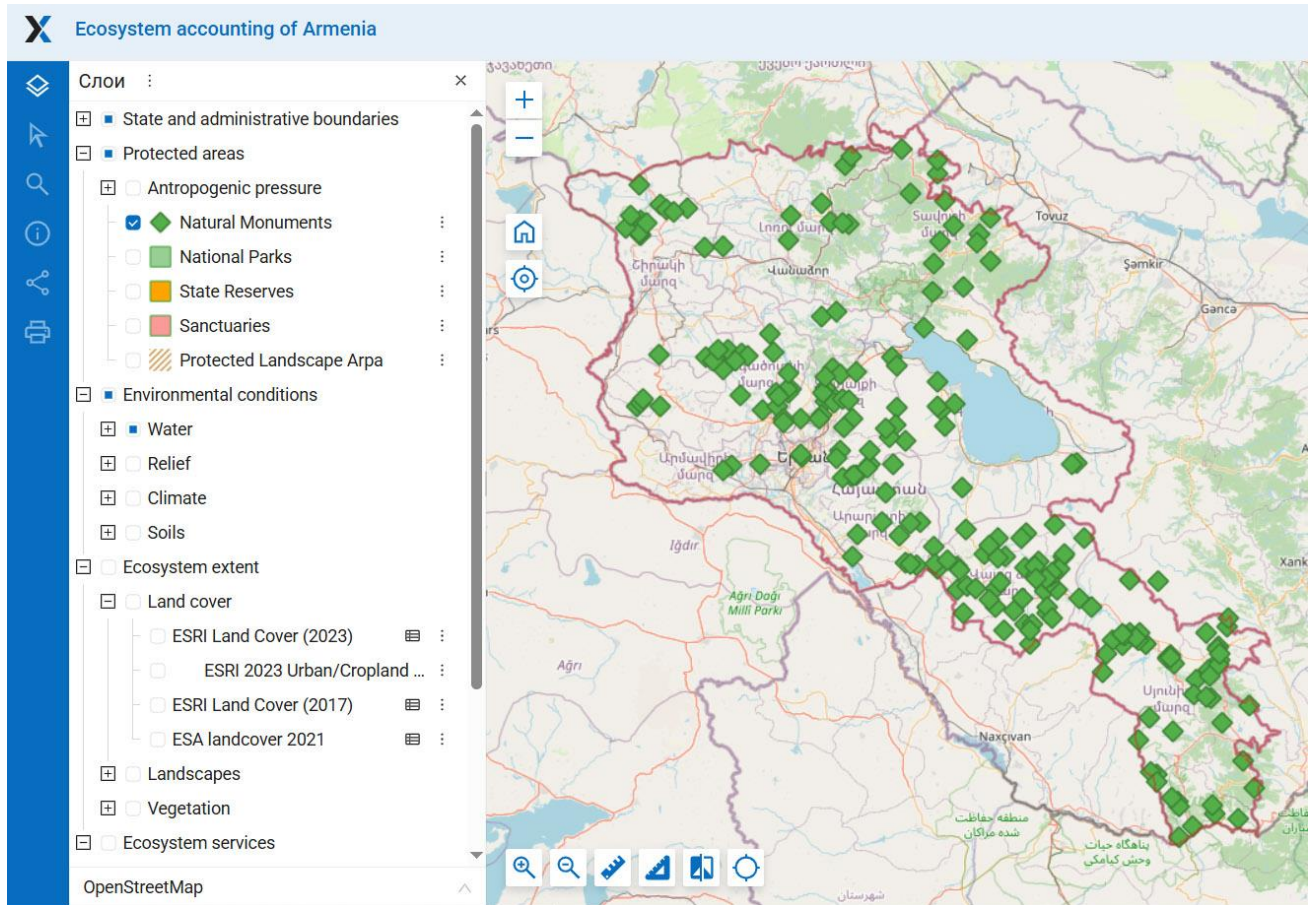

Figure 2.6.D-1. The map of natural monuments used (in details see project WEB GIS <https://bccarmenia.nextgis.com/> section "Protected areas"

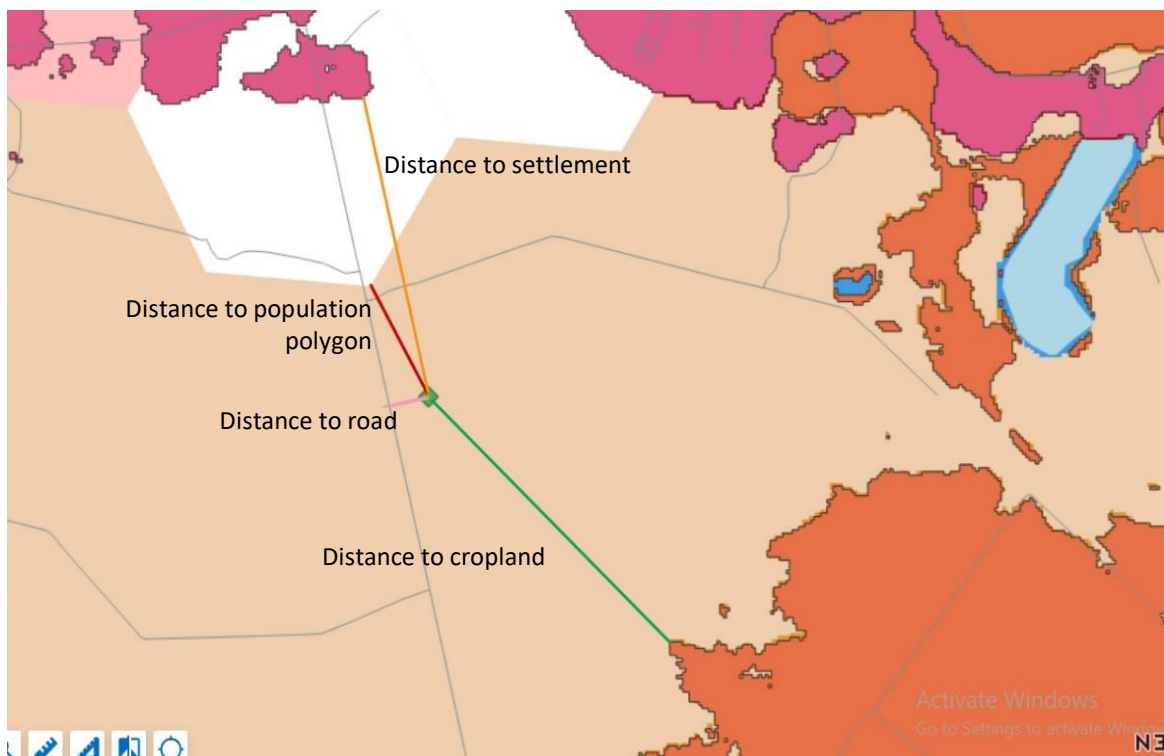

Figure 2.6.D-2. An example of distances for Dasak biological monument (shown as green diamond) in Armavir marz

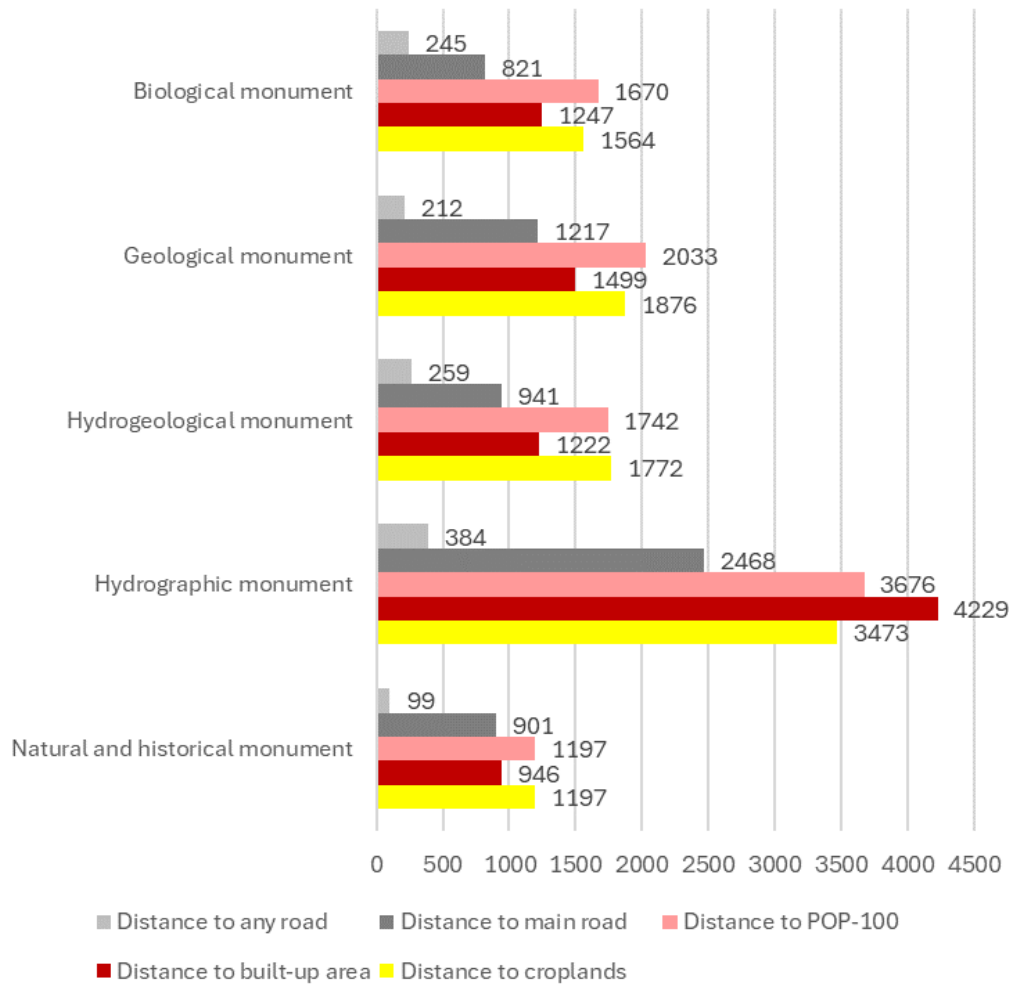

Figure 2.6.D-3. Distance from different categories of natural monuments to various types of anthropogenic areas and roads, in meters (Pop-100 - hexagons with a population of more than 100 people).

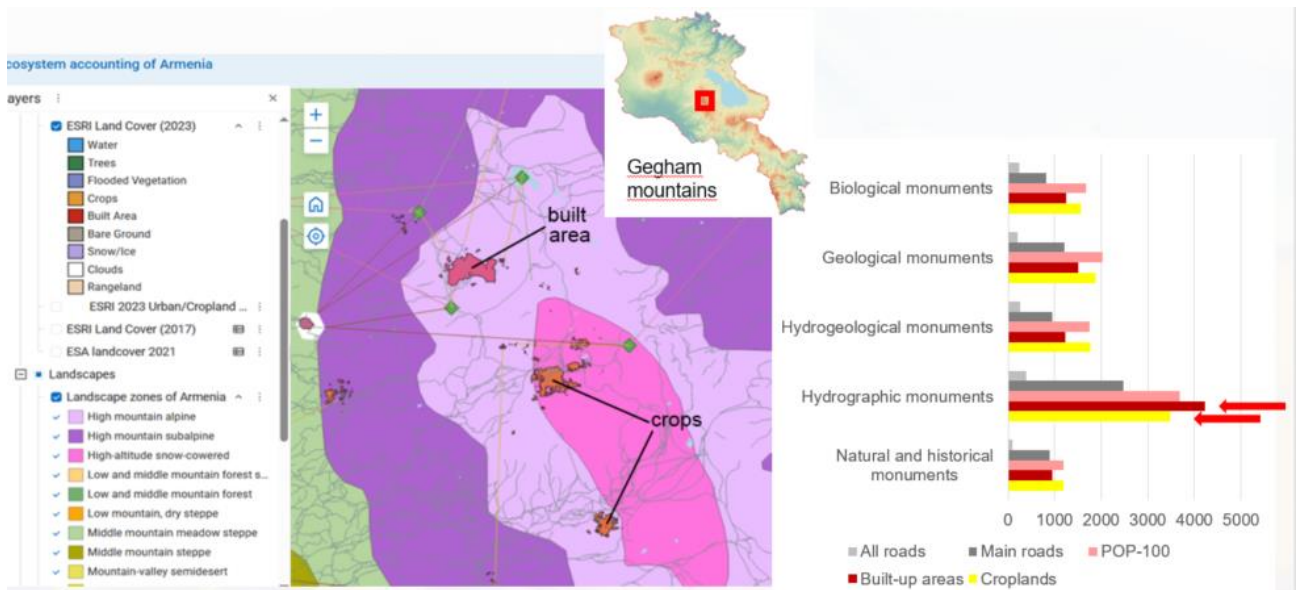

Figure 2.6.D-4. Erroneous underestimation of the distance between anthropogenic areas and hydrographic monuments due to Esri land cover mistakenly detecting croplands and built-up areas on the Gegham Ridge.

2.7. Approaches to integrating Armenia into the Global Ecosystem Atlas

2.7.A. Zero version of Armenian ecosystem map for the GEA

The Global Ecosystems Atlas (GEA)¹⁷ will be the first comprehensive harmonized open resource on the extent, change, condition and risk of all the world’s ecosystems. The inclusion of Armenia in the GEA is seen by us as an important step to demonstrate the international significance of national ecosystem accounting.

Our approach consists in the integration of a scientific vegetation map with regularly updated land cover data. Scientific map takes into account the ecological and biodiversity features of terrestrial ecosystems that are difficult or impossible to detect from space. Regularly updated land cover data allows for timely monitoring of changes in the extent of natural ecosystems. This approach was tested for extent accounting of natural vegetation types (Section 2.3) natural landscapes (Section 2.4) and LLCCs (Section 2.5).

To produce the zero-version map variants of ecosystems in Armenia for the GEA, we used the vegetation map developed within the project (Section 2.3) and two land cover datasets - Esri 2023 and ESA 2021 (10 m resolution). The vegetation map was recoded to IUCN Global Ecosystem Typology (GET) by George Fayvush.

The current area of natural terrestrial ecosystems, is defined as the potential area of a given vegetation type minus cropland and built-up areas based on land cover data. The current distribution of forests is also derived from land-cover data (Fig. 2.7.A-1).

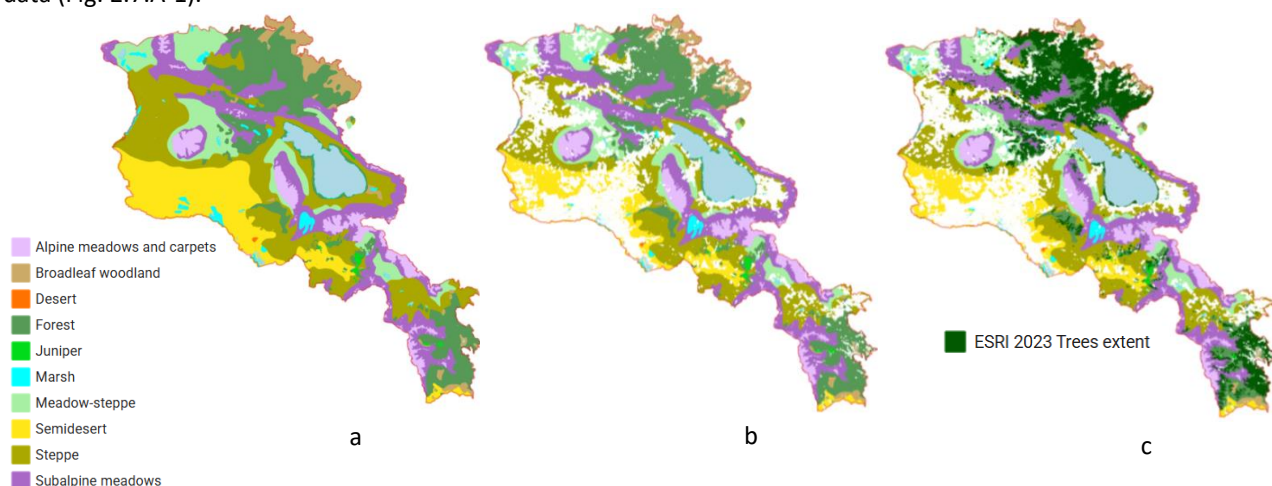

Figure 2.7.A-1. Main steps to produce a map of current terrestrial ecosystems using Esri data as an example: a) potential distribution of vegetation types; b) current natural area of vegetation zones excluding croplands and built-up areas; c) ecosystem types, including current tree cover. For detailed map see project Web GIS (<https://bccarmenia.nextgis.com>) sections Ecosystem Extent/Vegetation/Vegetation map 2025

The vegetation map, originally created as a vector dataset, was rasterized to a spatial resolution of 10 m and was subsequently reclassified into ecosystem types according to the IUCN GET. Four classes from land cover datasets were used and reclassified into the IUCN GET. Since the EA PV1 focuses exclusively on terrestrial ecosystems, aquatic ecosystems were not classified and were defined generally as Water (Table 2.7.A-1).

As our analysis comparing cropland areas from land cover datasets and Armstat data has shown (Section 2.1.B), tested land cover datasets include the following categories of agricultural land in the ‘cropland’ class:

- annually plowed areas (T7.1 Annual croplands);
- perennial agricultural plantations, i.e., vineyards and orchards (T7.3 Plantations);
- some of the fields that have not been plowed this year (T7.5 Derived semi-natural pastures and oldfields).

At this stage, we do not have the data necessary to separate these three categories within cropland land cover class, therefore, we reclassified it as T7.1 Annual croplands. Land categories such as “T7.2 Sown pastures and fields” and forest plantations aimed at timber production are not typical for Armenia; therefore, we did not consider them. Category “T7.5 Derived semi-natural pastures and oldfields” can be found in three vegetation zones: meadow-steppe, steppe, and semidesert. However, at this stage, we do not have the data necessary to identify T7.5 within these zones.

¹⁷ <https://globalecosystemsatlas.org/>

Table 2.7.A-1. Reclassification of vegetation map and land cover classes to the IUCN GET

		IUCN GET
Vegetation map of Armenia	Alpine vegetation	T6.4 Temperate alpine grasslands and shrublands
	Subalpine meadows	T4.5 Temperate subhumid grasslands
	Meadow-steppe	T4.5 Temperate subhumid grasslands
	Steppe	T5.1 Semi-desert steppes
	Grasslands within forest vegetation zone	T4.5 Temperate subhumid grasslands
	Juniper woodlands	T4.4 Temperate woodlands
	Broadleaf woodlands	T4.4 Temperate woodlands
	Semidesert	T5.1 Semi-desert steppes
	Desert	T5.1 Semi-desert steppes
Land cover data	Trees; Tree cover	T2.2 Deciduous temperate forests
	Built-up areas	T7.4 Urban and industrial ecosystems
	Crops; Croplands	T7.1 Annual croplands
	Water; Permanent water bodies	Water

Four classes (trees, crops, built areas, water) from the Esri 2023 and ESA 2021 land-cover datasets were overlaid onto the vegetation raster using a priority-based approach; that is, these classes replaced the underlying vegetation class, while all other pixels retained their original vegetation classification. Thus, two versions of the map with a 10 m resolution were produced based on Esri and ESA data.

Next, ESA- and Esri-based 10 m categorical rasters were aggregated to a 100 m resolution using a majority (modal) resampling approach. For each 100 m cell, the corresponding block of 10 × 10 underlying 10 m pixels (100 pixels in total) was identified, and the ecosystem class occurring most frequently within that block was assigned to the output cell. NoData values were excluded from the calculation. This approach preserves categorical integrity and avoids artificial class mixing that would result from averaging or interpolative resampling methods. Resulting rasters are ESA_based_100m.tif and Esri_based_100m.tif (Figure 2.7.A-2).

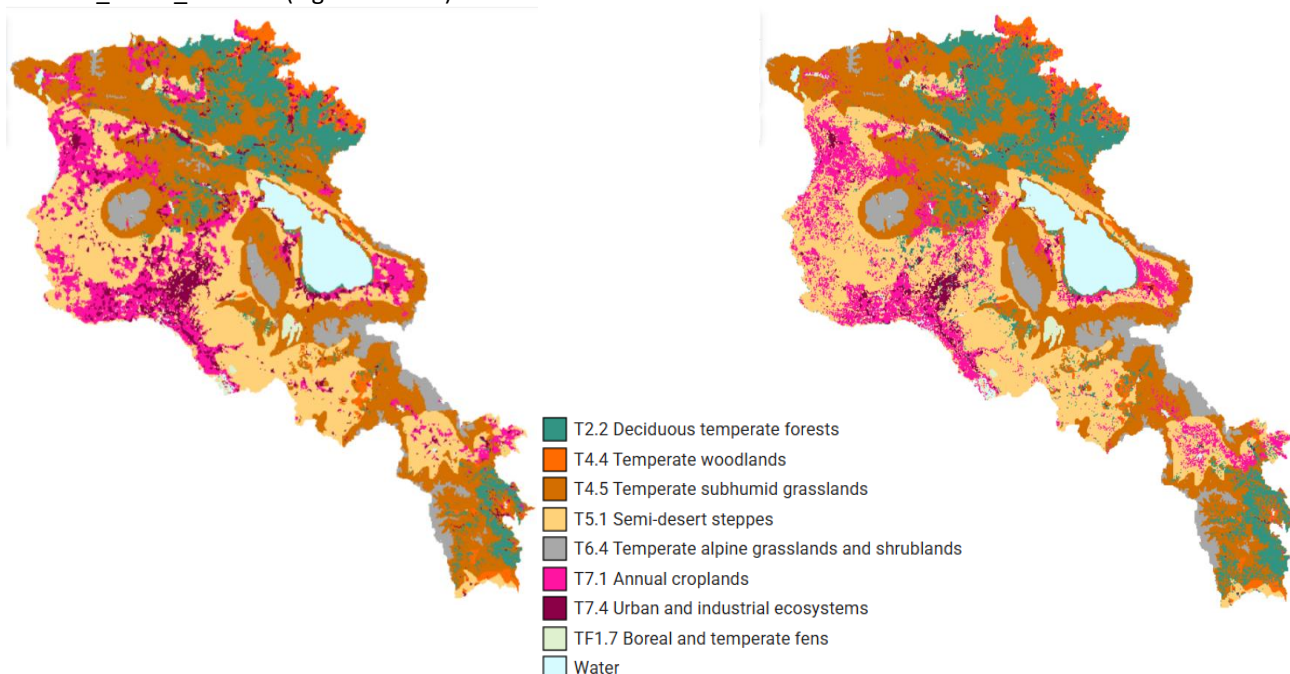

Figure 2.7.A-2. Maps of current terrestrial ecosystems of Armenia based on Esri 2023 and ESA 2021 land cover data. See details in project WEB GIS (<https://bccarmenia.nextqis.com/resource/644/display?panel=layers>), section “Armenia in GEA”

Due to differences in the methodologies used by Esri and ESA to identify built-up areas, croplands, and tree cover, the resulting maps show noticeable differences in the areas of these classes. The more detailed ESA land-cover dataset identifies grasslands, croplands, and tree cover within settlement areas; therefore, in the raster based on ESA data, built-up area is smaller than in the raster based on Esri data and some settlements with a high density of trees (small private gardens, street trees, and parks) are identified in the ESA data predominantly as tree cover (Fig. 2.7.A-3).

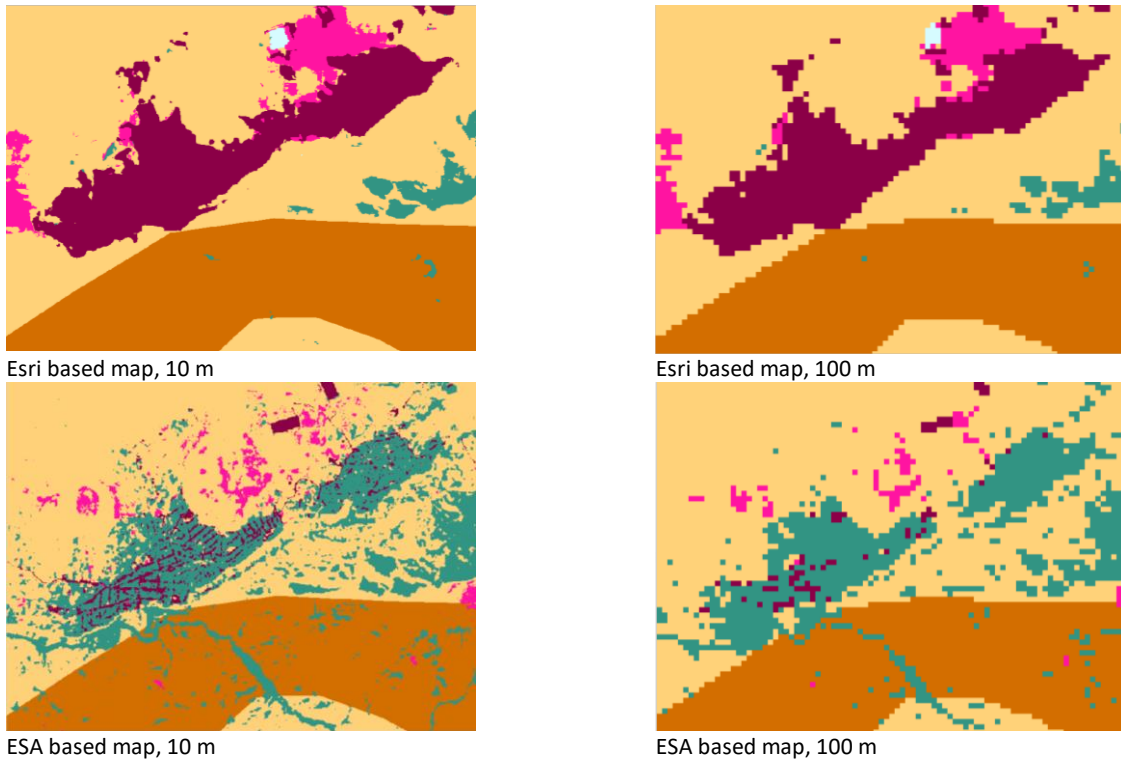

Figure 2.7.A-3. The settlement of Garni in the map versions based on Esri and ESA data.

However, according to the understanding of urban ecosystem types in the IUCN GET, all tree-covered, herbaceous, and vacant land areas located within urban boundaries are considered part of urban ecosystems. Therefore, we considered it appropriate to provide the GEA team with two additional versions of the map, in which all areas within settlement boundaries are assigned to class T7.4 Urban and industrial ecosystems.

Settlement areas were delineated using OpenStreetMap data by combining administrative boundaries of towns and the city of Yerevan (Fig. 2.7.A-4 a) with built-up area polygons which represent the actually built-up areas of settlements at a lower hierarchical level than towns and city Yerevan ((Fig. 2.7.A-4 b). These features were merged into a single settlement layer (Fig. 2.7.A-4 c), which was overlaid onto the ESA- and Esri-based rasters and classified as T7.4 Urban and industrial ecosystems. Resulting rasters are ESA_OSM_100m.tif and Esri_OSM_100m.tif (Figure 2.7.A-5).

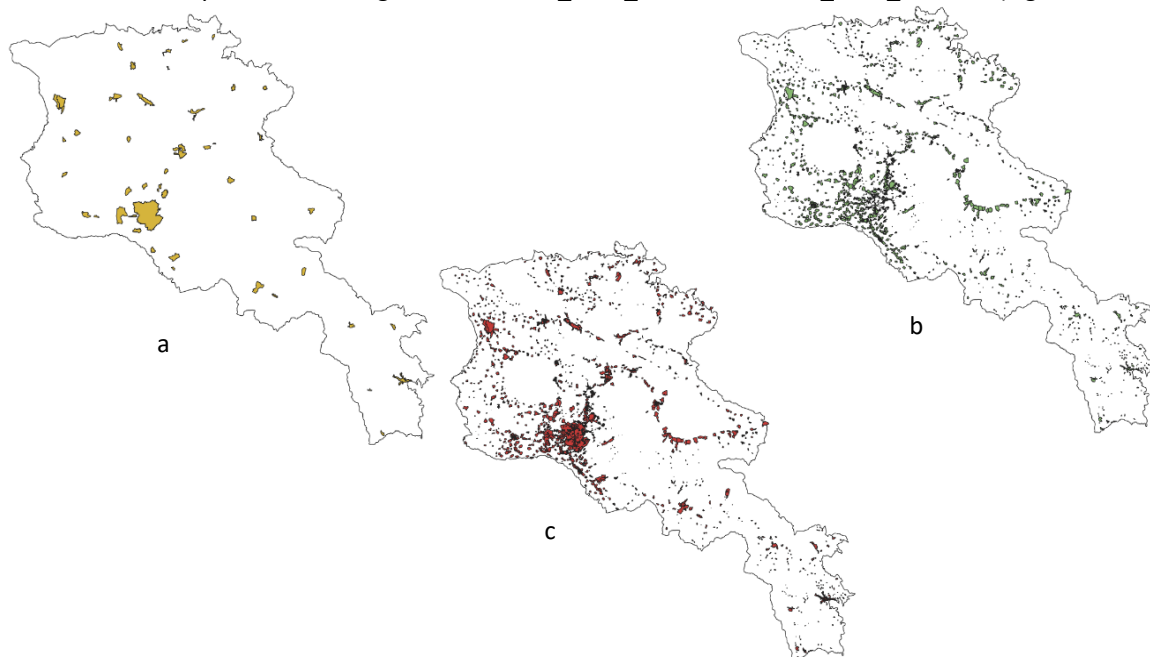

Figure 2.7.A-4. Used OSM layers: (a) administrative boundaries of towns and the city of Yerevan; (b) built-up area

polygons; (c) combined layer.

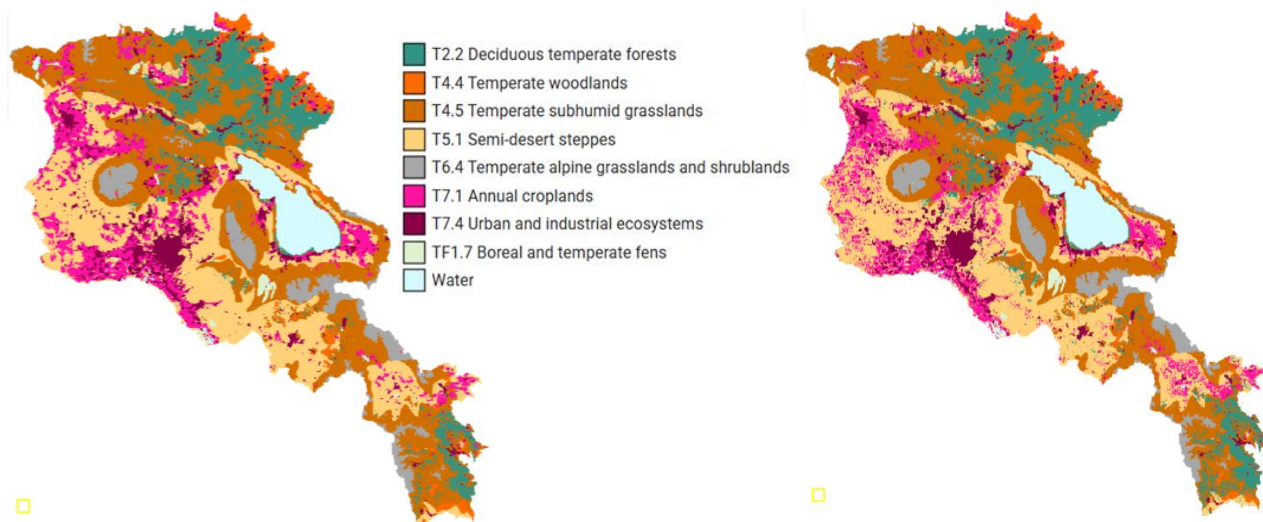

Figure 2.7.A-5. Maps of current terrestrial ecosystems of Armenia based on Esri 2023 and ESA 2021 land cover data and built-up areas from OSM. See details in project WEB GIS

<https://bccarmenia.nextgis.com/resource/644/display?panel=layers>, section “Armenia in GEA”

2.7.B. Ecosystem extent according IUCN Global Ecosystem Typology

Area of ecosystem types according to the IUCN GET is shown in Table 2.7.B. The largest areas are occupied by T4.5—Temperate subhumid grasslands (32–33%) and T5.1—Semi-desert steppes (26–27.5%). Substantially smaller areas are occupied by T2.2—Deciduous temperate forests (10–13%) and T6.4—Temperate alpine grasslands and shrublands (6%), while minor areas are represented by T4.4—Temperate woodlands (3%) and TF1.7—Boreal and temperate fens (less than 1%). Anthropogenic areas, depending on the map version, account for 13–18%: croplands 10–11% and built-up areas 2–7%. The overall pattern of ecosystem extent differs most strongly for the map based on ESA data (Fig. 2.7.B), due to the substantially lower built-up area and higher areas of grasslands, forests, and croplands, resulting from the inclusion of their area located within settlements (see above).

Table 2.7.B. Ecosystem area in Armenia and across marzes in different versions of ecosystem map, km²

		T2.2 Deciduous temperate forests	T4.4 Temperate woodlands	T4.5 Temperate subhumid grasslands	T5.1 Semi-desert steppes	T6.4 Temperate alpine grasslands and shrublands	T7.1 Annual croplands	T7.4 Urban and industrial ecosystems	TF1.7 Boreal and temperate fens	Water
Based on ESA 2021	Aragatsotn	87.4	0	662.7	1290.8	204	449.9	34	2.6	4.6
	Ararat	70.1	9.4	260.4	1215.5	37.7	341.4	95.9	52.3	32.4
	Armavir	7.2	0	0	645.3	0	492.9	100.4	12.7	4.9
	Gegharkunik	145.3	39.4	1971.5	878.9	396.6	390.6	58.8	93.9	1273.1
	Kotayk	211.1	1.8	672.9	770.5	116	265.4	64.8	10	2.4
	Lori	1024.4	35	1985.3	405.7	44.5	184.7	47.7	32.8	3.1
	Shirak	13.2	0	906.5	878.2	127.4	663.7	64.8	35.5	29.3
	Syunik	857.2	140	1768.6	770.2	542.3	380.7	12.9	3.5	17.8
	Tavush	1479.6	473.4	653.6	5.8	0.4	79.6	30.4	0	3.5
	Vayotz Dzor	112.2	86.8	697.8	1125.6	214.9	51.7	4.2	0.7	2.4
Yerevan	11.9	0	0	92.8	0	4.7	123.1	0	0.8	
TOTAL	4019.6	785.9	9579.3	8079	1683.7	3305.1	637	243.9	1374.2	
Based on Esri 2023	Aragatsotn	47.8	0	644.5	1255.2	203.5	438	138.6	5.2	3.1
	Ararat	25.4	9.4	271.3	1202	37.6	306.7	176.9	54.4	31.4
	Armavir	0.5	0	0	456.2	0	611.1	182.4	6.9	6.3
	Gegharkunik	128.2	31.1	1915.9	813.2	396.3	403.3	194	91.9	1274.3
	Kotayk	153.2	2	661.1	725	114.2	265.6	183.4	8.1	2.5
	Lori	881.9	40.6	1986.4	329	44.4	298.5	148.5	30.5	3.4
	Shirak	13	0	804.2	829.8	127.8	742.2	142.2	29	30.3
	Syunik	502.3	166.2	2036.6	920.4	540.8	231.9	73.6	6.6	15.2
	Tavush	1318.6	493.6	726.4	6.4	0.4	81	95.7	0	4.2
	Vayotz Dzor	36.2	102.3	720.3	1142	214.8	32.7	45.1	0.8	2.2

	Yerevan	0.4	0	0	56.6	0	7.8	167.8	0	0.7
	TOTAL	3107.3	845.1	9766.7	7735.7	1679.7	3418.7	1548.2	233.2	1373.5
Based on ESA 2021 and OSM	Aragatsotn	59.4	0	646.8	1227.8	202.3	431.7	161.5	2.7	4.5
	Ararat	61.4	9.4	259.2	1183.8	37.1	306.8	175.3	50.2	31.7
	Armavir	4.9	0	0	588.6	0	431.2	224.5	9.8	4.6
	Gegharkunik	137.5	36.1	1923.4	824.8	396.7	340.2	222.1	94.6	1272.8
	Kotayk	174	1.5	647.9	726.8	115.2	254.9	184.9	8.2	1.4
	Lori	988.8	29	1941.5	375.6	43.6	167.8	183.2	30.5	2.9
	Shirak	10.1	0	890.7	821.1	127.6	628	177.1	34.7	29.2
	Syunik	819.4	138.5	1745.1	757.2	542.5	375.6	94.5	3.3	17.5
	Tavush	1435.7	453.2	643.1	5.7	0.3	78.4	106.4	0	3.5
	Vayotz Dzor	86.9	85.2	682.8	1101.5	215.8	50.5	70.7	0.7	2.4
	Yerevan	0.4	0	0	13.6	0	0.8	218.3	0	0
	TOTAL	3778.5	753	9380.4	7626.7	1681	3065.7	1818.4	234.7	1370.4
Based on Esri 2023 and OSM	Aragatsotn	47.7	0	642.6	1235.7	202	421.8	178.6	5.2	3.1
	Ararat	25.6	9.5	270.7	1192.7	37.1	290.8	203.5	53.7	31.5
	Armavir	0.5	0	0	441.1	0	563.6	246.1	6.3	6.1
	Gegharkunik	125.6	30.8	1897.7	803.2	396.6	386.3	241.4	92.7	1273.9
	Kotayk	150.3	1.7	650.1	712	113.2	256	222.3	7.6	1.4
	Lori	875.1	35.5	1966.5	320.7	43.5	288.4	200	30.2	3
	Shirak	13	0	799.7	813.5	127.6	718.3	187.3	29	30.2
	Syunik	502	164.4	2014.9	914	541.1	229.6	106.4	6.6	14.6
	Tavush	1314.2	486	718.9	6.3	0.3	78.3	118.2	0	4.2
	Vayotz Dzor	32.6	101.8	709.9	1126.8	215.7	30	76.6	0.8	2.2
	Yerevan	0	0	0	11.2	0	0.6	221.4	0	0
	TOTAL	3086.6	829.7	9671	7577.2	1677.1	3263.6	2001.8	231.9	1370

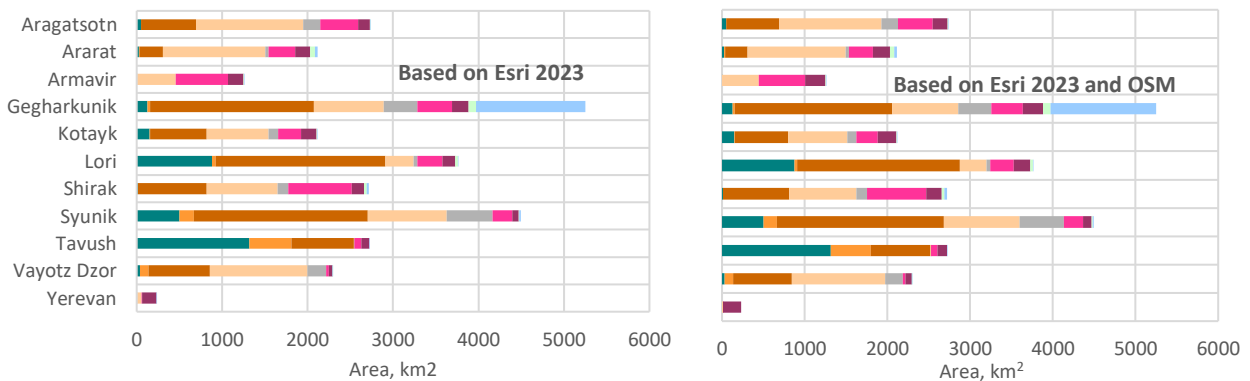
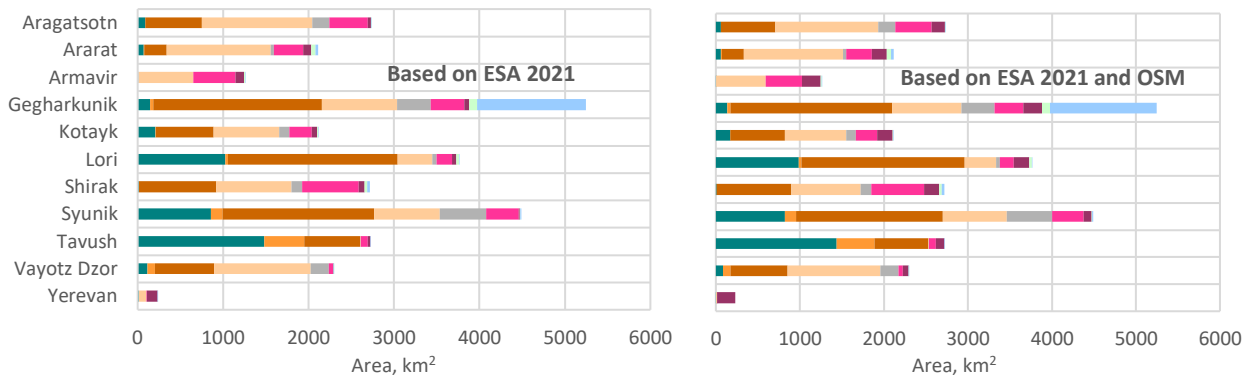
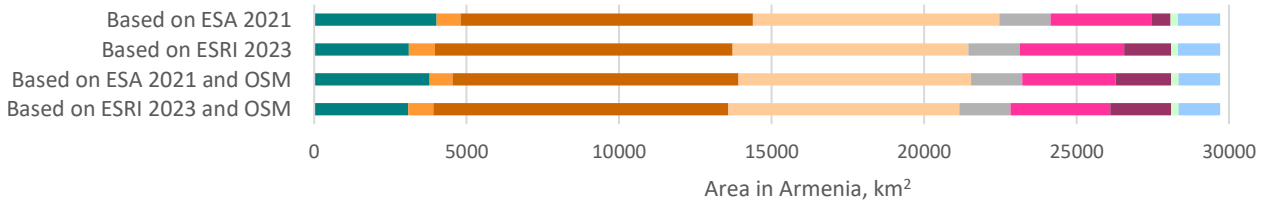

- T2.2 Deciduous temperate forests
 - T4.5 Temperate subhumid grasslands
 - T6.4 Temperate alpine grasslands and shrublands
 - T7.4 Urban and industrial ecosystems
 - Water
- T4.4 Temperate woodlands
 - T5.1 Semi-desert steppes
 - T7.1 Annual croplands
 - TF1.7 Boreal and temperate fens

Figure 2.7.B. Ecosystem area in Armenia and across marzes in different versions of ecosystem map, km²

2.7.C. Comparison of Zero version maps for the GEA with government-reported data

To compare the created variants of the ecosystem maps with government-reported land cover class area data for 2022¹⁸, all non-forest ecosystem classes in our maps were aggregated into a single class. All versions of created maps show cropland areas that are smaller than those reported in the official government statistics, while the area of non-forest ecosystems is larger. This indicates that part of croplands included in government statistics is identified as grassland by the land-cover datasets. Built-up area in maps created for the GEA exceeds the values reported in government statistics, except for the map version based on ESA data, where the built-up area is substantially smaller. With respect to forest area, the map versions based on ESA data show better agreement with the government statistics (Figure 2.7.C-1).

The sum of the absolute differences between class areas in the created maps and the government statistics is smallest for the map based on ESA and OSM data - ESA_OSM_100m.tif (Figure 2.7.C-2).

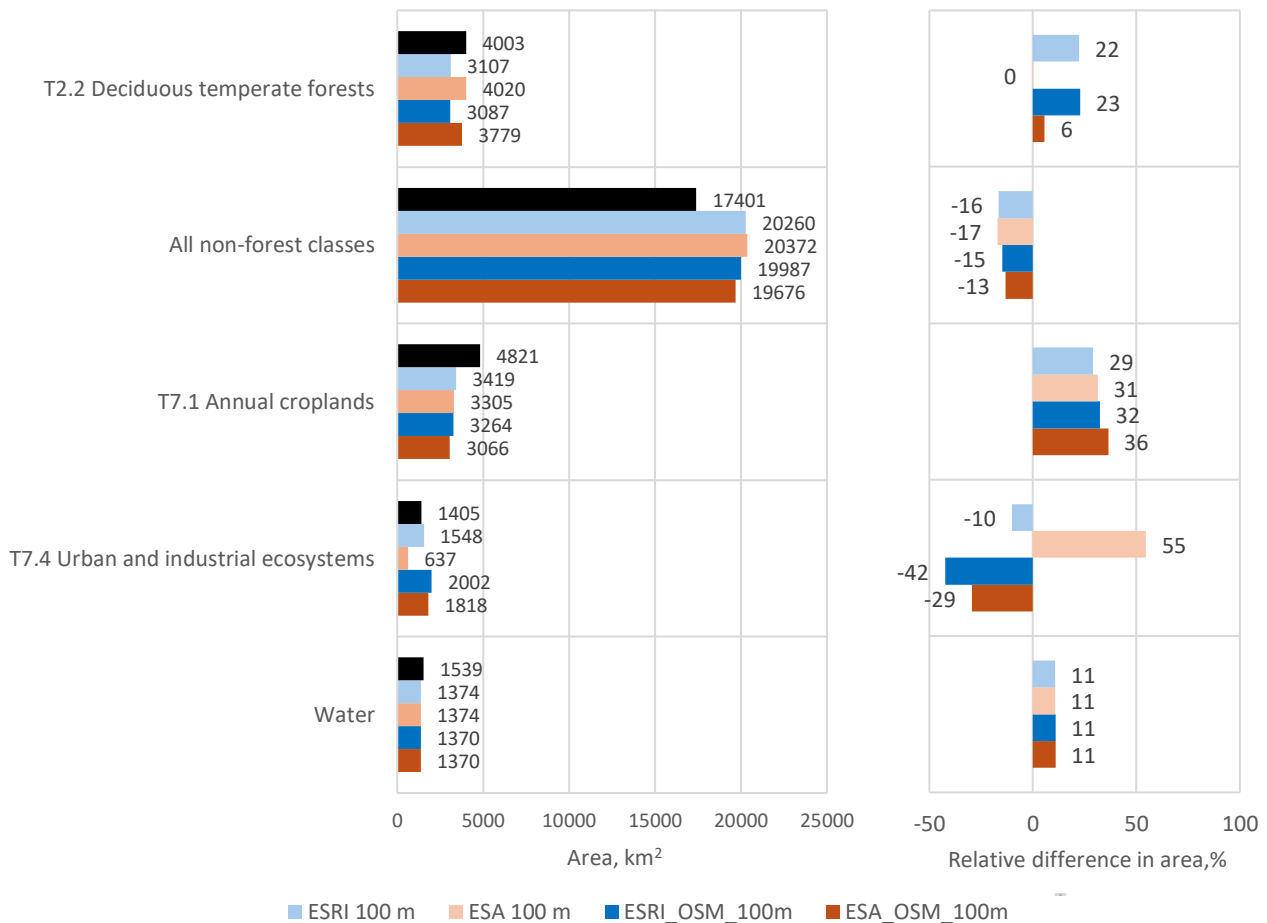

Figure 2.7.C-1. Area of main land cover classes in ecosystem maps created for GEA and in Government-reported data (a) and relative differences in area between GEA maps and government statistics, % of Government-reported area (b)

¹⁸ <https://www.arlis.am/hy/acts/171671>

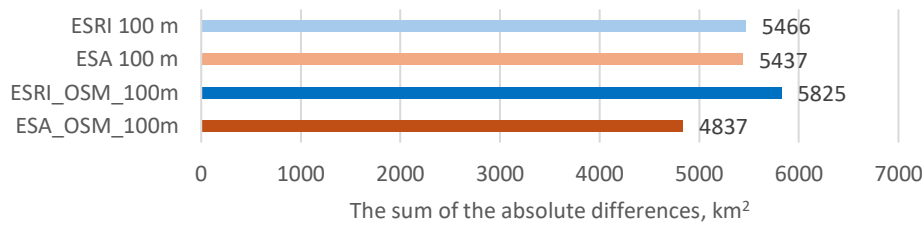

Figure 2.7.C-2. The sum of the absolute differences between maps for GEA and government statistics

2.7.D. Subsequent versions of the map

As shown by our analysis (Section 2.1), all global land cover datasets contain significant errors, and therefore, the ecosystem map of Armenia and the ecosystem accounting should eventually be based on a corrected national land cover dataset.

Currently, we are at the stage of the **Zero version** of the map, which can be created based on the Prototype ecosystem accounting V1 and available global land cover datasets. Moving forward, two main stages of improvement for this map can be foreseen. Along this path, improvements are needed both in the vegetation map and in the land cover data.

Version 1 may be based on a detailed map of Armenian ecosystems developed using the ELU approach (Section 4.2C) as well as certain refinements of land cover data:

- Corrections of obvious errors in land cover data (e.g., built-up areas and croplands in high mountain zones);
- Creation of tree cover map with two classes – closed forest and open woodlands

Version 2 should be based on an accurate national land cover dataset including

- Refinement of T7.1 Annual cropland areas;
- Identification of T7.3 Plantation areas (vineyards and orchards)
- Identification of T7.5 Derived semi-natural grasslands, which requires analysis of satellite imagery and agricultural statistics not only for the current period but also for previous years.

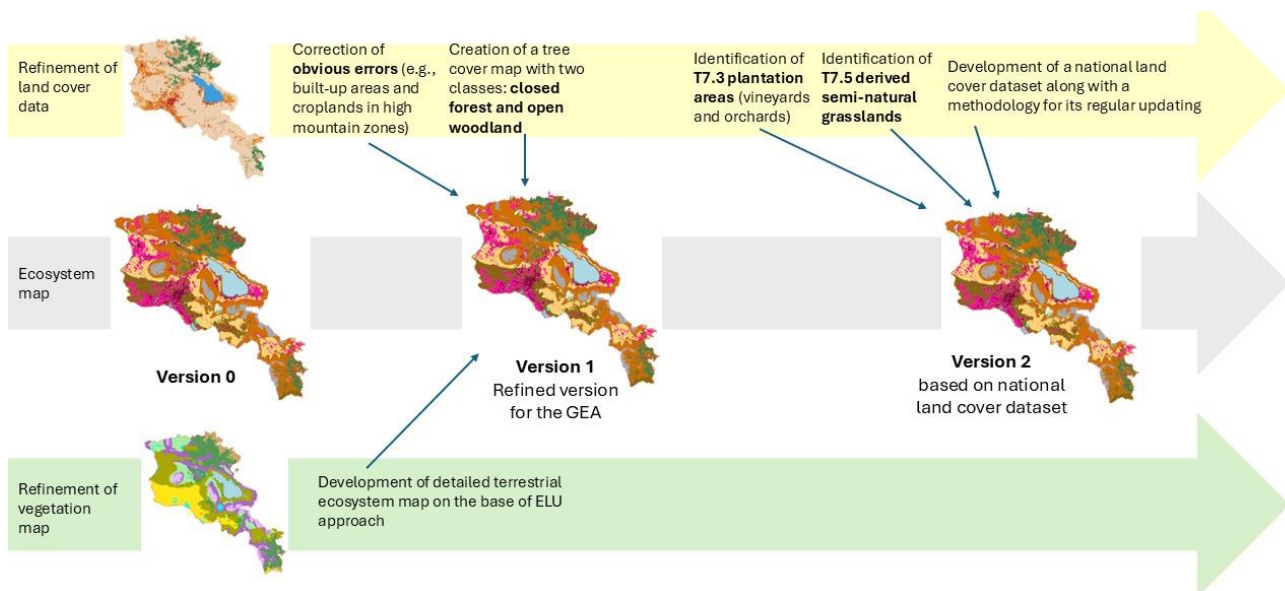

2.8. Examples of EE accounting tables

Explanations are provided in the corresponding sections

Extent of land cover classes by Government-reported data (Section 2.2.A)

EE accounting table: Table 2.2.A-2. Land cover classes in 2020 and 2024, by Government-reported data, ha

	Cultivated lands	Grasslands	Tree-covered areas	Shrub-covered areas	Water covered areas	Vegetation-free areas
Opening extent in 2020	538361.22	1366386.9	400522.06	34200.612	151491.8	483295.83
Additions to extent				NA		
Managed expansion				NA		
Unmanaged expansion				NA		
Reductions in extent				NA		
Managed reductions				NA		
Unmanaged reductions				NA		
Net change in extent	1259.3	-2700.46	-18160.9	173.718	20626.01	-1197.1
Closing extent in 2024	539620.52	1363686.44	382361.15	34374.33	172117.81	482098.73

EE by economic units: Table 2.2.A-3. Land cover class extent by marzes in 2022 by Government-reported data, ha

	Tree-covered areas	Grasslands	Shrub-covered areas	Vegetation-free areas	Water covered areas	Cultivated	Buil-up
Aragatsotn	8571.9	163313.3	392.5	20565.3	2189.9	67143.7	15095.6
Ararat	12724.74	99272.39	2496.22	35572.84	7090.2	40224.09	11061.98
Armavir	582.41	29283.57	634.13	17666.4	3010.438	60572.6	11345.59
Gegharkunik	21889.88	238054.4	3635.07	39933.93	124010.7	90318.54	17289.28
Kotayk	20810.43	102757.6	2313.48	20405.93	1661.12	45813.84	13820.73
Lori	86365.8	200387.6	4830.7	23510.69	4751.58	48300.81	11717.3
Shirak	4598.8	144403.9	0	13622.23	3427.13	83846.24	18128.89
Syunik	80905.01	194761.5	15742.25	91253.96	5576.07	47958	14345
Tavush	133659.9	82690.46	2943.31	10681.01	1094.24	31359.26	7970.77
Vayots Dzor	28325.5	114823.3	1147.9	60825.9	923.4	20109.42	4857.7
Yerevan	1845.1	1001.2	0	1133.29	155.61	3283.62	14909.08
Armenia	400279.5	1370749	34135.56	335171.5	153890.4	538930.1	140541.9

Extent of land cover classes by Esri land cover data (Section 2.2.B)

Transition matrix: Table 2.2.B-3. Land cover class transition matrix from 2017 to 2023, km²

	Tree cover	Grasslands	Bare ground	Snow/Ice	Water	Flooded veg.	Crops	Built-up	Total area in 2017	Reduction
Tree cover →	2909.87	362.79	0.02	0.05	0.58	0.02	3.74	2.72	3279.79	369.92
Grasslands →	224.03	19221.76	2.12	7.56	13.46	1.74	940.92	114.62	20526.21	1304.45
Bare ground →	0.05	75.63	29.67	3.70	1.97	0.24	2.10	2.59	115.94	86.27
Snow/Ice →	0.01	0.49	0.04	0.33	0.01	0.00	0.02	0.06	0.96	0.63
Water →	0.44	8.74	2.29	0.04	101.20	0.47	7.41	1.53	122.12	20.92
Flooded veg. →	0.05	3.34	0.05	0.00	4.48	4.78	1.81	0.87	15.37	10.59
Crops →	3.04	444.42	0.42	0.29	6.62	1.18	2478.53	97.21	3031.70	553.17
Built-up →	3.27	25.79	0.76	0.03	0.50	0.02	14.40	1335.95	1380.72	44.77
Total area in 2023	3140.75	20142.95	35.35	12.00	128.82	8.46	3448.92	1555.56	28472.82	
Expansion	230.88	921.19	5.69	11.67	27.62	3.68	970.39	219.61		2390.73

EE accounting table: Table 2.2.B-4. The Land-cover class extent in 2017 and 2023, based on Esri data, km²

	Trees	Grass	Bare ground	Snow/Ice	Water	Flooded veg.	Crops	Built-up
1. Opening extent in 2020	3279.79	20526.21	115.94	0.96	122.12	15.37	3031.70	1380.72
2. Additions to extent	230.88	921.19	5.69	11.67	27.62	3.68	970.39	219.61
3. Managed expansion	NA							
4. Unmanaged expansion	NA							
5. Reductions in extent	369.92	1304.45	86.27	0.63	20.92	10.59	553.17	44.77
6. Managed reductions	NA							
7. Unmanaged reductions	NA							
8. Net change in extent	-139.04	-383.26	-80.59	11.04	6.70	-6.91	417.22	174.83
9. Closing extent in 2024	3140.75	20142.95	35.35	12.00	128.82	8.46	3448.92	1555.56

EE by economic units: Table 2.2.B-2. The extent of land cover classes in 2023 by marse based on Esri data, km²

	Grasslands	Trees	Bare ground	Snow/Ice	Flooded veg.	Water	Crops	Built Area	Total
Aragatsotn	2,096.86	48.25	3.48	6.38	0.00	3.50	438.49	139.17	2,736.12
Ararat	1,560.01	26.20	6.94	0.04	6.74	32.42	305.46	177.10	2,114.91
Armavir	461.83	0.55	2.05	0.00	0.15	7.10	609.26	182.76	1,263.70
Gegharkunik	3,239.85	129.56	4.28	0.94	0.65	1,274.08	404.99	193.66	5,248.00
Kotayk	1,508.64	153.10	1.08	1.60	0.00	2.57	265.38	182.43	2,114.80
Lori	2,424.92	883.74	2.83	0.31	0.79	3.81	298.87	147.73	3,763.00
Shirak	1,784.67	13.43	0.91	2.47	0.00	31.48	742.89	142.79	2,718.63
Syunik	3,650.25	507.74	12.65	0.09	0.02	15.86	233.22	73.53	4,493.35
Tavush	1,227.75	1,316.33	0.05	0.04	0.02	4.35	82.03	95.67	2,726.24
Vayots Dzor	2,174.55	38.13	2.51	0.35	0.00	2.35	33.28	45.37	2,296.54
Armenia	20,185.02	3,117.51	37.33	12.21	8.39	1,378.29	3,422.08	1,547.66	29,708.49

Extent of natural vegetation types (Section 2.3)

Transition matrix: Table 2.3.C-1. Aggregated vegetation type transition matrix from 2017 to 2023, km²

	Alpine vege- tation	Sub-alpine mea-dows	Mea-dow- step-pe	Step-pe	Grassl. in forest zone	Juni-per	Broad-leaf wood-land	Semi-desert	De- sert	Marsh	For-ests	Water and flood. veg.	Crops	Built-up	Total area in 2017	Reduction
Alpine veg.	1642.9	0.0	0.0	0.0	0.0	0.0	0.0	0.0	0.0	0.0	0.4	0.2	2.3	0.1	1645.9	3.0
Subalpine meadows	0.0	4216.6	0.0	0.0	0.0	0.0	0.0	0.0	0.0	0.0	19.6	0.5	60.9	2.9	4300.5	83.8
Meadow-steppe	0.0	0.0	2552.1	0.0	0.0	0.0	0.0	0.0	0.0	0.0	10.9	2.3	270.0	6.2	2841.5	289.4
Steppe	0.0	0.0	0.0	5039.5	0.0	0.0	0.0	0.0	0.0	0.0	11.3	1.0	370.2	21.3	5443.2	403.8
Grassl. in forest zone	0.0	0.0	0.0	0.0	2628.1	0.0	0.0	0.0	0.0	0.0	143.6	1.4	54.9	22.2	2850.2	222.1
Juniper	0.0	0.0	0.0	0.0	0.0	127.5	0.0	0.0	0.0	0.0	0.9	0.0	0.2	0.2	128.8	1.2
Broadleaf woodland	0.0	0.0	0.0	0.0	0.0	0.0	640.4	0.0	0.0	0.0	36.2	2.5	24.9	6.6	710.6	70.2
Semi-desert	0.0	0.0	0.0	0.0	0.0	0.0	0.0	2274.9	0.0	0.0	1.1	4.4	142.5	55.8	2478.5	203.6
Desert	0.0	0.0	0.0	0.0	0.0	0.0	0.0	0.0	6.8	0.0	0.0	0.0	0.0	0.3	7.1	0.3
Marsh	0.0	0.0	0.0	0.0	0.0	0.0	0.0	0.0	0.0	212.5	0.2	5.1	17.1	1.9	236.8	24.3
Forests	3.2	62.5	11.4	22.7	238.5	2.0	18.8	3.3	0.0	0.4	2909.9	0.6	3.7	2.7	3279.8	369.9
Water/flooded veg.	0.2	0.4	1.2	0.8	1.8	0.0	0.6	4.2	0.0	5.3	0.5	110.9	9.2	2.4	137.5	26.6
Crops	1.3	12.6	20.3	162.8	21.8	0.0	35.5	179.1	0.1	11.5	3.0	7.8	2478.5	97.2	3031.7	553.2
Built-up	0.1	1.4	2.4	6.8	6.6	0.2	2.3	6.0	0.0	0.8	3.3	0.5	13.7	1336.6	1380.7	44.1
Total area in 2023	1647.6	4293.5	2587.4	5232.6	2896.8	129.7	697.7	2467.6	6.9	230.6	3140.7	137.1	3448.2	1556.3	28472.8	2295.46
Expansion	4.8	76.9	35.3	193.1	268.8	2.2	57.2	192.7	0.1	18.0	230.9	26.2	969.7	219.7	2295.5	

EE accounting table: Table 2.3.C-2. Accounting table of vegetation type extent for 2017 and 2023, km²

	Alpine vegetation	Sub-alpine meadows	Meadow-steppe	Steppe	Grassl. in forest zone	Juniper	Broad-leaf woodland	Semi-desert	Desert	Marsh	Forests
Opening extent in 2017	1645.93	4300.46	2841.47	5443.24	2850.19	128.78	710.63	2478.53	7.06	236.81	3279.79
Additions to extent	4.76	76.90	35.29	193.11	268.77	2.17	57.23	192.71	0.06	18.04	230.88
Managed expansion	NA										
Unmanaged expansion	NA										
Reductions in extent	3.05	83.84	289.36	403.76	222.11	1.24	70.20	203.62	0.27	24.26	369.92
Managed reductions	NA										
Unmanaged reductions	NA										
Net change in extent	1.71	-6.94	-254.06	-210.66	46.66	0.93	-12.97	-10.92	-0.21	-6.22	-139.04
Closing extent in 2024	1647.64	4293.52	2587.41	5232.59	2896.85	129.71	697.67	2467.61	6.85	230.59	3140.75
Additional row – see Section 4											
Closing extent in 2024 of ecosystems unconverted since 2017	1642.88	4216.62	2552.11	5039.48	2628.08	127.54	640.43	2274.91	6.79	212.55	2909.87

EE by economic units: Table 2.3.D-1. The extent of natural vegetation types by marzes in 2023, km²

	Alpine vegetation	Subalpine meadows	Meadow-steppe	Steppe	Forest	Juniper	Broadleaf woodland	Semi-desert	Desert	Marsh
Aragatsotn	202.59	106.04	524.94	525.73	48.88	0	0	743.31	0	7.05
Ararat	37.16	64.63	30.77	751.66	187.13	0	9.46	470.97	6.89	64.27
Armavir	0	0	0	0	0	0	0	456.02	0	7.73
Gegharkunik	391.05	1307.91	405.23	824.14	334.03	20.62	10.63	0	0	92.94
Kotayk	113.68	208.24	234.95	451.72	370.1	0	1.68	279.08	0	8.18
Lori	44.06	904.53	656.93	362.86	1224.23	0	73.41	0	0	31.88
Shirak	126.14	397.7	408.82	819.41	0	0	0	17.15	0	53.23
Syunik	530.55	878.07	295.18	803.66	1337.58	13.74	164.17	115.78	0	12.95
Tavush	0.31	275.54	0	11.81	1541.85	0	701.92	0	0	0
Vayots Dzor	212.47	390.5	78.74	773.48	280.41	100.79	4.65	369.73	0	1.47

3. Ecosystem services

3.1. Regulating ES

3.1.A. Methods of assessment of water-related regulating ES

3.1.A1. General modeling framework

Four of the six regulating and maintenance services assessed are closely linked to the water cycle via evapotranspiration and indicators of surface runoff and baseflow. They were assessed using the InVEST (Integrated Valuation of Ecosystem Services and Tradeoffs) integrated tool:

- Seasonal water flow regulation and baseflow provision (InVEST Seasonal Water Yield);
- Prevention of soil water erosion and sediment export in waterbodies (InVEST Sediment Delivery Ratio);
- Flood risk mitigation (InVEST Urban Flood Risk Mitigation);
- Cooling effect of terrestrial ecosystems (InVEST Urban Cooling).

The modeling framework simulated current (2023) and past (2017) conditions, as well as alternative land-cover scenarios, to evaluate ecosystem services (ES) provided by terrestrial ecosystems and to detect changes in these services (Figure 3.1.A1-1). To calculate ES values across the different EAAs, we used the administrative boundary map from the Forest Atlas of Armenia and the vegetation map developed under the project (Section 2.3). A comparison of the modeling results with Armstat water-use data was conducted to assess the supply–use balance, thereby demonstrating the relevance of ES accounting data for evidence-based decision-making on water use and territorial development.

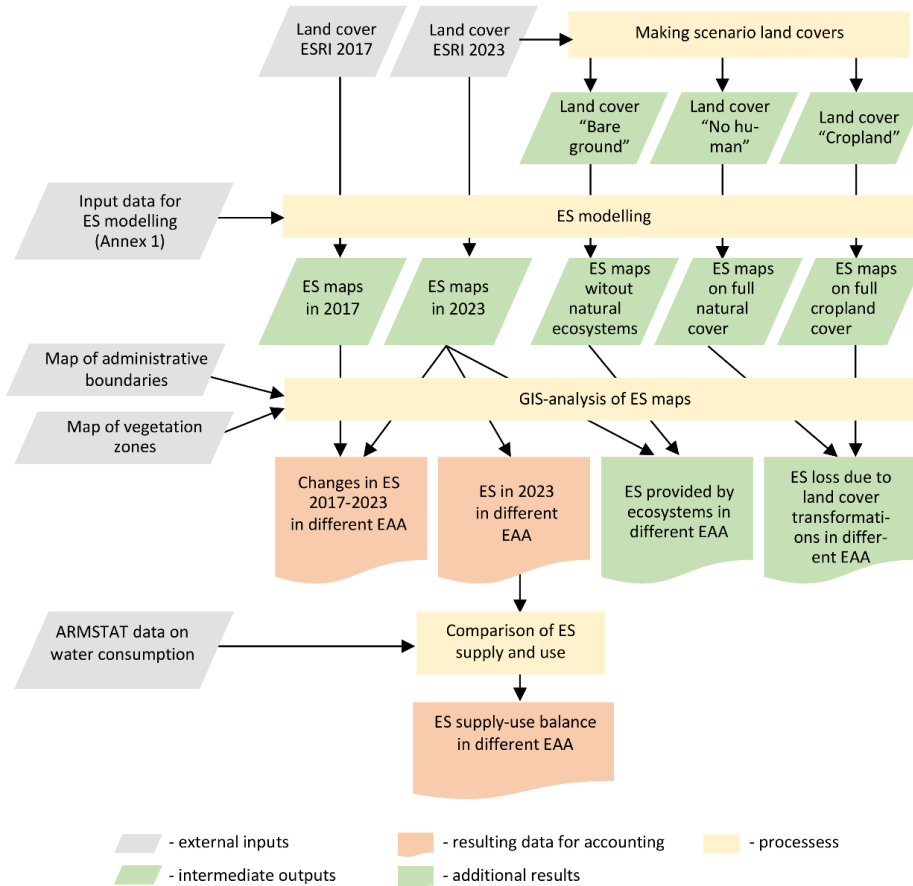

Figure 3.1.A1-1. Flow-chart of ES assessment.

3.1.A2. The InVEST models used

The ES of seasonal water flow regulation and baseflow provision was estimated and mapped with InVEST Seasonal Water Yield (SWY) model which estimates the impact of terrestrial ecosystems on the total amount of water flow and its seasonal redistribution. Based on monthly precipitation, reference evapotranspiration, soil permeability, topography, and the land use/land cover (LULC), the model calculates two key indicators: quick flow and baseflow. Quick flow represents the portion of precipitation that runs off during or shortly after a rain event (within hours to days). Baseflow is the portion of precipitation that gradually enters streams through subsurface flow with watershed residence times ranging from months to years. Baseflow plays a crucial role in maintaining water flow during dry periods and mitigating the impacts of drought.

The ES of prevention of soil water erosion and sediment export in waterbodies was estimated and mapped with InVEST Sediment Delivery Ratio (SDR) model which estimates the impact of terrestrial ecosystems on soil water erosion and sediment export into streams. The model relies on the widely used Universal Soil Loss Equation (USLE) and Sediment Delivery Ratio that estimates the ratio between the amount of sediment eroded from each land pixel, the amount of sediment that is trapped along the flow path downslope from this pixel, and the amount of sediment that reaches a stream. Based on rainfall erosivity, soil erodibility, topographic, and LULC data, the model calculates potential and avoided erosion and sediment export into streams. Thus, the model evaluates and maps two ecosystem services simultaneously: prevention of soil water erosion and ensuring water flow quality.

The ES of flood risk mitigation was estimated and mapped with InVEST Urban Flood Risk Mitigation (UFRM) model which calculates two main indicators: (1) the runoff retention, i.e., the amount of runoff retained by soil and vegetation when modeling rainfall; (2) the runoff (Q), mm, which is a potentially hazardous factor that can cause flooding. These calculations were based on LULC, soil hydrologic groups, watersheds and climate data.

Cooling effect of terrestrial ecosystems was estimated and mapped with InVEST Urban Cooling (UC) model which is primarily aimed at assessing the cooling effect of green spaces within urban areas. However, it also allows for evaluating this effect over large areas outside of cities. Since the assessment of urban ES is not a goal of our project, we focused on the ES of areas outside settlements. We used the Cooling Capacity Calculation Method, which estimates *cooling capacity* based on evapotranspiration, albedo, shade (the proportion of area that is covered by tree canopy), air temperature in a rural reference area, and the Urban Heat Index (UHI), i.e., the difference between the rural reference temperature and the maximum temperature observed in the city. We modeled this ES for the hottest season in Armenia—July and August.

Detailed descriptions of the models can be found in the above-mentioned sections of the InVEST website and in the InVEST User Guide (Natural Capital Project).

3.1.A3. Model inputs

Table 3.1.A3-1. Model inputs

Data Type	Models	Sources	Resolution	Notes
LULC	SWY, SDR, UFRM, UC	Esri land cover data	10 m	Data for 2017 and 2023
Soil hydrologic groups	SWY, SDR, UFRM	Soil map of Armenia from (Interactive Forest Atlas)	Vector map	The hydrological soil groups were defined in accordance with USDA recommendations (The United States, 2009): A—slightly and moderately stony sand; very stony sandy loam; B—slightly and moderately stony sandy loam; very stony loam; C—slightly and moderately stony loam; very stony clay; D—slightly and moderately stony clay. The obtained map of soil hydrologic groups is presented on the project’s webGIS https://bccarmenia.nextgis.com
Soil erodibility (K-factor)	SDR	Soil map of Armenia from (Interactive Forest Atlas)	Vector map	A soil erodibility map was obtained on the basis of soil textures using the following coefficients from the InVEST User Guide (Natural Capital Project): 0.0290 for clay, 0.0395 for loam, 0.0171 for sandy loam, 0.0026 for sand.
Digital elevation model	SWY, SDR	https://dataspace.copernicus.eu/explore-data/data-collections/copernicus-contributing-missions/collections-description/COP-DEM	30 m	-
Watershed boundaries	SWY, SDR, UFRM	HydroSHEDS https://www.hydrosheds.org/products/hydrobasins	Vector map	The analysis was made for parts of watersheds that are located on the territory of Armenia: Aghstev, Akhuryan, Arpa, Debed, Hrazdan, Metsamor, and Vorotan (Figure 31A3-1)

Climate data (annually and monthly precipitation and temperature)	SWY, UFRM< UC	https://www.worldclim.org/data/index.html	30 arc seconds *	The amount of liquid precipitation has been adjusted to take into account the snow period (see below)
Rain events table	SWY, UFRM	http://armenia.pogoda360.ru		The number of rainy days for each climatic zone was calculated as the average for several cities located within that zone. In the moderate-cool climate zone, where there are no cities, the average data for this zone is based on three cities situated near its border https://biodiversity-armenia.am/en/seea-ea/ongoing-projects/preliminary-results-on-ea/seasonal-water-yield
Climate zones of Armenia	SWY, SDR, UC, UFRM	The map of climate zones of Armenia (Interactive Forest Atlas)	Vector map	The digital vector map of climate zones of Armenia was generalized to the four climate zones: (1) Arid; (2) Moderate dry; (3) Moderate cool; (4) Moderate humid. For details, see the project's WebGIS https://bccarmenia.nextgis.com Figure 31A3-2
Monthly reference evapotranspiration (ETO)	SWY, UC	https://cgiarcsi.community/data/global-aridity-and-pet-database	30 arc seconds *	-
Crop coefficients Kc	SWY, UC	https://www.fao.org/4/x0490E/x0490e0b.htm ; https://www.fao.org/4/x0490e/x0490e0h.htm#frozen%20or%20snow%20covered%20surfaces		Kc was determined for the four climate zones. The used Kc is presented at the project website https://biodiversity-armenia.am/en/seea-ea/ongoing-projects/preliminary-results-on-ea/seasonal-water-yield
Crop vegetation periods	SWY, UC	https://www.fao.org/giews/earthobservation/country/index.jsp?code=ARM#		Vegetation periods were determined for the four climate zones
Leaf Area Index	SWY, UC	https://land.copernicus.eu/en/products/vegetation/leaf-area-index-300m-v1.0		The LAI values for dates in the middle of the month were used
Curve numbers (CN)	SWY, UFRM	Asante et al., 2008; Hong and Adler, 2008, United States, 1986		Coefficients for medium hydrological conditions and vegetation states were used. For croplands and rangelands, differences in climatic zones were considered http://armenia.pogoda360.ru
C-factor for crops	SDR	Panagos et al., 2015		C-factor was defined as average values for Europe: 0.3 for crops and sparse vegetation, 0.05 for rangelands (average between pastures and low productive grasslands), and 0.0014 for forests (average value for Southern European countries). C-factor was considered equal to zero for water, flooded vegetation, built areas, and snow/ice on the InVEST recommendations.
P-factor	SDR	-		P-factor was considered equal to 1 because we did not take into account special anti-erosion measures
Rainfall erosivity	SDR	https://esdac.jrc.ec.europa.eu/content/global-rainfall-erosivity	30 arc sec *	
Albedo	UC	Panagos et al., 2015		The following albedo values were used for land cover classes: water and flooded vegetation 0,6; trees 0.15; rangeland 0.2; crops 0.2; built-up area 0.17; bare ground 0.25; snow/ice 0.9
Shade	SDR	-		The following shade values were used for land cover classes: built-up – 0.2; forests – 1.0; croplands, taking into account the share of orchard area, in the arid climate zone – 0.35, in the moderate-dry and moderate-cool zones – 0.03, in the moderate-humid zone – 0.34, other land cover classes – 0.
UHI effect	UC	Yale Center for Earth Observation (YCEO), Global Surface UHI Explorer https://yceo.users.earthengine.app/view/uhiemap?utm_source=chatgpt.com		The UHI value was set to zero

* At latitude 40°, 30 arc seconds correspond to an area of approximately 709 by 390 m.

53

54 For the SWY, SDR and UFRM models, we used those portions of level-6 watersheds that lie within Armenia. These
 55 parts of the watersheds are further named after their largest rivers (Figure3.1.A1-3a):

- 56 – Aghstev (involves Getik and Voskepar tributaries)
- 57 – Akhuryan
- 58 – Arpa (involves the Arpa River, the Azat River and the Vedi River)
- 59 – Debed (involves Pambak and Dzoraget tributaries)

- 60 – Hrazdan (involves two parts – Lake Sevan drainage basin and its outlet River Hrazdan)
- 61 – Metsamor (involves Kasagh tributary)
- 62 – Vorotan (involves Vorotan River, the Voghji River, and the Meghri River).
- 63 Note that these are not the basins of the named rivers themselves, but the portions of larger basins, named after the
- 64 largest river present in each portion.
- 65 For comparing ES supply and use, it is important that the watershed boundaries largely coincide with marz boundaries
- 66 (Figure 3.1.A1-3b).

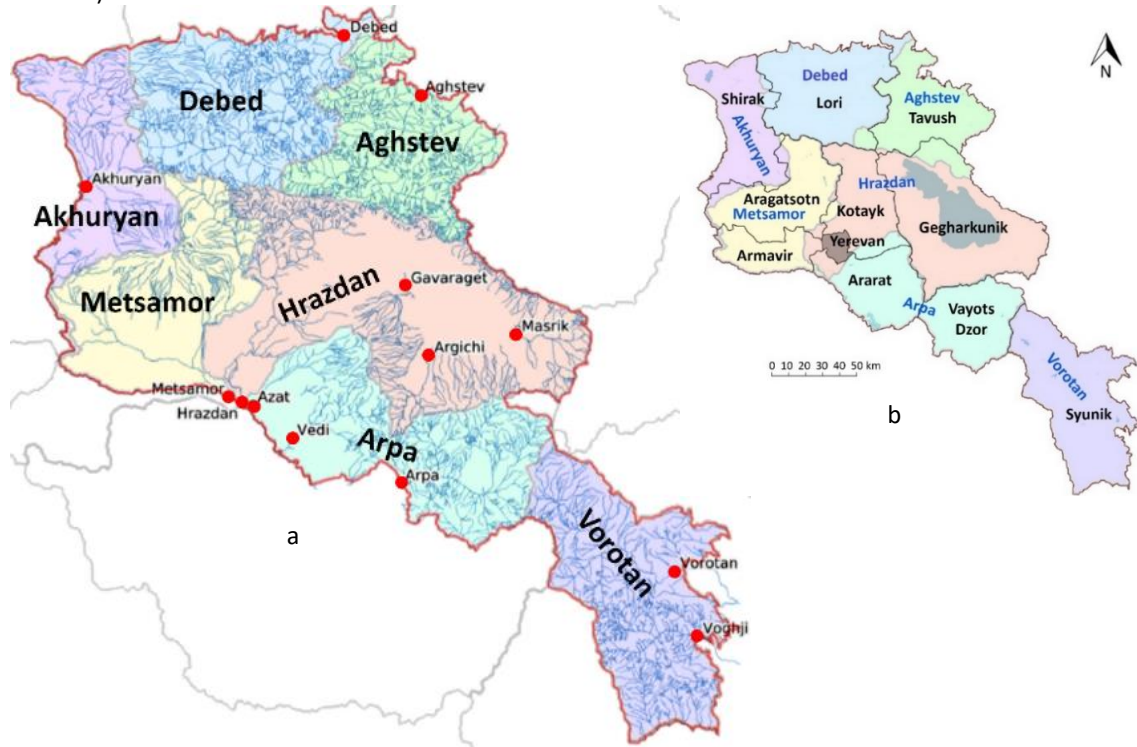

67
 68 *Figure 3.1.A3-1. Watersheds used for ES modeling: a) Watersheds and points of cumulative baseflow values in the lower*
 69 *reaches of rivers; b) Boundaries of marzes and watersheds, the boundaries and names of the marzes are shown in black;*
 70 *the watersheds are shown in different colors with blue labels.*

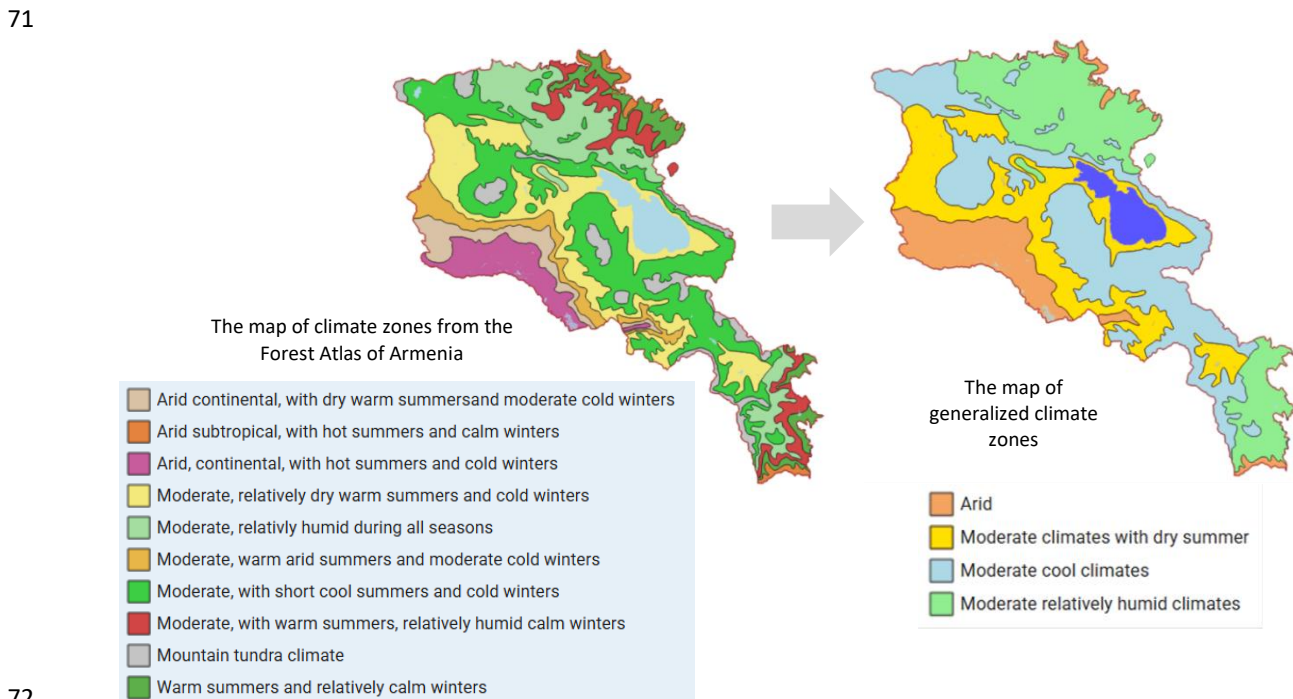

72
 73 *Figure 3.1.A3-2. Generalization of climate zones for ES modeling*

Crop coefficients (K_c) were defined as average values for the main groups of agricultural crops, based on FAO data¹⁹. Areas of various agricultural crops such as grains and legumes, vegetables, potatoes, melons, fruits and berries, and grapes in the provinces of Armenia in 2023 were obtained from the regional statistics of Armstat²⁰. To calculate K_c for croplands, we averaged the area shares of different crops for four climatic zones based on data from provinces predominantly located in one or another zone. Average K_c values were then calculated for croplands in each climatic zone, taking into account the share of the area of different agricultural crops within it. K_c values for bare soil were determined based on Allen et al., 2005 as the average values for different soil types. For natural vegetation (rangeland and trees), in accordance with the recommendations of InVEST (Natural Capital Project), K_c values were set as $K_c = 1$ if $LAI > 3$ and $K_c = LAI/3$ if $LAI \leq 3$. According to InVEST and FAO recommendations²¹, $K_c = 1$ was used for water and flooded vegetation, $K_c = 0.35$ —for built-up areas (assuming that impervious surfaces account for 50%), and $K_c = 0.4$ —for permanent snow. The values of other coefficients were taken from the InVEST User Guide recommendations (Natural Capital Project).

UHI effect is incorporated into UC model as a single value. Calculations based on a single UHI value for all of Armenia are impractical due to the significant variation in conditions across different cities. The global UHI effect map²² shows that in Armenia, it has varying values with opposite signs in different settlements—some settlements are warmer than their surroundings, while others are colder, which makes the use of this factor biased (QGIS Association, 2025). Therefore, we decided not to account for this factor and set the UHI value to 0.

The values of other coefficients were taken from the InVEST User Guide recommendations (Natural Capital Project).

Regional Armstat statistics on water consumption in 2023 were used to estimate the consumption of ESs.

The coefficients used for the modeling are presented in Appendix 3.1.A

3.1.A4. Scenarios used for ES modeling and assessment of the ES provided by ecosystems

To estimate the role of natural ecosystems in ES provisioning, we used three hypothetical LULC scenarios:

- Bare ground scenario: all vegetation, including forests and grasslands, was replaced with bare ground;
- Cropland scenario: all areas, except for urban territories and water bodies, were converted to cropland;
- No-human scenario: urban areas and croplands were replaced with grasslands, simulating a landscape without human activity.

One of the tested models—SDR—directly calculates ES values provided by ecosystems, i.e., indicators of avoided erosion and avoided sediment export. The other models calculate ES indicators for a given LULC but do not determine what portion of these values is attributable to ecosystems rather than to physical processes. In the SWY and UFRM models, we estimated the volume of ES provided by ecosystems as the difference between ES values for the current land cover and the bare ground scenario. Thus, negative indicator values (for the ecosystem effect) mean that ecosystems decrease the indicator, while positive values mean that ecosystems increase it.

The cropland scenario was used in the SWY model to compare ES loss resulting from the replacement of natural vegetation with bare ground and croplands. The no-human scenario was used in the UFRM model to estimate possible ES loss in historical time due to anthropogenic land transformation.

We tested the flood mitigation ES model (UFRM model) for average and extreme spring rainfall scenarios. The highest precipitation in Armenia falls in May and June. While precipitation levels vary significantly across different climatic zones, for the initial model testing, we considered it reasonable to use countrywide average values. During these months, an average rainfall event delivers 12 mm of precipitation. For the extreme

3.1.A6. Data preprocessing and assimilation

Data preprocessing

To ensure the correct use of data in InVEST models, preprocessing was performed using the QGIS 3.40 application (QGIS Association, 2025) and custom Python 3.10.4 scripts.

Land cover data plays a critical role in all InVEST models. The source data were provided as raster files in GeoTIFF format, which we cropped based on Armenia's national borders. Distinct versions of land cover rasters were created for different modeling scenarios using custom Python scripts—bare ground, cropland, and grassland—by modifying pixel values according to each scenario. For example, in the bare ground scenario, all pixels with values 2 (forest) and 11 (rangeland) were converted to 8 (bare land).

We then juxtaposed land cover rasters for different scenarios with the climate zones dataset using a raster calculator, which allowed a transition from basic categories such as “forest” and “cropland” to enriched classifications like “forest in

¹⁹ <https://www.fao.org/4/X0490E/x0490e0b.htm>

²⁰ <https://armstat.am/en/?nid=651>

²¹ <https://www.fao.org/4/x0490e/x0490e0h.htm#frozen%20or%20snow%20covered%20surfaces>

²² https://yceo.users.earthengine.app/view/uhimap?utm_source=chatgpt.com

124 an arid zone” and “cropland in a moderately humid zone”. The climate zone data were originally provided as a vector
125 layer in GeoPackage format. It was rasterized in QGIS to ensure that the resulting raster matched the land cover raster in
126 extent, resolution, and spatial reference system, with climate zones assigned numerical values from 1 to 4.

127 Then, we combined land cover and climate zone rasters in a two-step process: 1) the pixel values of the land cover
128 raster were multiplied by 100; 2) these adjusted values were added to the corresponding pixel values of the climate zone
129 raster, resulting in a unified dataset.

130 For example, a final pixel value of 204 indicates that the pixel represents land cover type 2 (e.g., trees) and climate
131 zone 4 (e.g., moderate humid zone).

132 ***Incorporating snow dynamics in the SWY model***

133 Since the SWY model does not account for the snow period, we assumed zero liquid precipitation during the winter
134 months when the average temperature is below zero and added this amount to the precipitation of the spring months,
135 when the average temperature rises above zero. The estimation was made without taking into account the sublimation
136 of snow at subzero air temperatures. Digital monthly maps of liquid precipitation are presented on project Web GIS
137 (<https://bccarmenia.nextgis.com>).

138 To calculate monthly liquid precipitation, we used a combination of mean monthly air temperature and mean monthly
139 precipitation data. These datasets were provided as raster coverages in GeoTIFF format and unified in terms of spatial
140 extent and resolution.

141 A Python script was used to iterate through the rasters based on the following logic:

142 - If the mean monthly air temperature in a pixel was below zero, precipitation in that pixel for that month was set to
143 0, and its value was carried over to the same pixel in the next month’s precipitation raster;

144 - If the mean monthly temperature remained negative in the following month, the accumulated total was carried
145 forward again until the temperature became positive. At that point, all accumulated snow melted, generating a
146 cumulative water flow.

147 ***Data preparation for InVEST and statistic calculation***

148 For compatibility with InVEST, all raster datasets were resampled to match the spatial domain of the land cover
149 dataset, ensuring uniform spatial extent, resolution, and coordinate reference system for accurate model execution.
150 These tasks were carried out using standard QGIS 3.40 tools²³, including raster alignment and raster calculator. All raster
151 files were prepared in GeoTIFF format, which is supported by both QGIS and InVEST.

152 Vector zones required for InVEST models were stored in GeoPackage format 1.3.1 and projected into the same
153 coordinate reference system as the raster datasets.

154 The results of InVEST model computations, represented as raster coverages, were aggregated based on the
155 boundaries of three vector layers: Armenia’s provinces, major river basins, and vegetation zones. Two standard QGIS
156 tools were used for aggregation, zonal statistics for calculating pixel-based sums and averages within the zones, and zonal
157 histogram for counting the number of pixels of different values within each zone.

²³ <http://www.qgis.org>

158
159
160
161
162
163
164
165
166
167
168

3.1.B. Baseflow provision (InVEST SWY)

The ES of seasonal flow redistribution and baseflow provision is extremely important for Armenia, which has a seasonal climate with dry summers over a significant part of the territory. The ES was estimated and mapped using InVEST Seasonal Water Yield model²⁴. The model takes into account the monthly amount of precipitation, soil permeability, and the water balance of each pixel, including moisture that comes into it from the overlying pixels. The main resulting indicators for assessing the ecosystem service are quick flow (QF), that is, the generation of streamflow with watershed residence times of hours to days; and baseflow (B), that is the generation of streamflow with watershed residence times of months to years. Values of cumulative baseflow (Bsum) show the flow through a pixel, contributed by all upslope pixels (Figure 3.1.B-1). Baseflow ensures runoff maintaining during the dry season and possible droughts.

The baseflow and quick flow values computed by the SWY model are relative measures (InVEST User Guide).

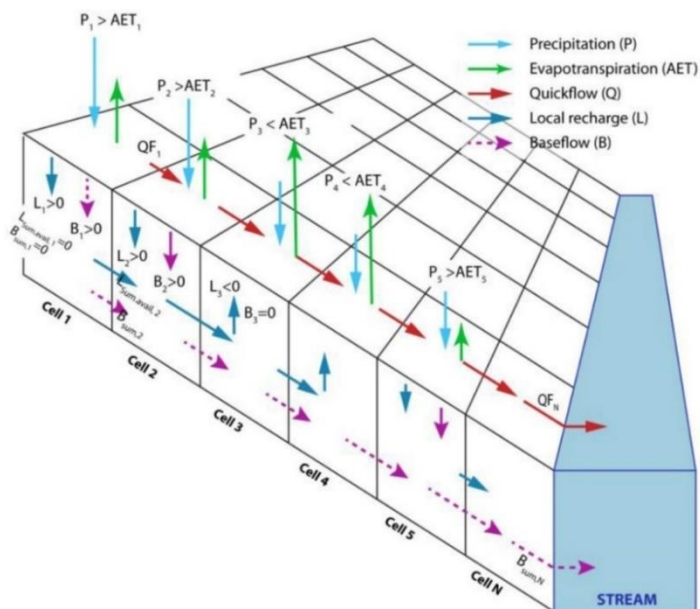

Figure 3.1.B-1. The InVEST Seasonal Water Yield model diagram (from Hamel et al., 2020)

169
170
171
172
173
174
175
176
177
178
179
180
181
182
183
184

3.1.B1. Potential ES provided by terrestrial ecosystems

Modelled relative ES indicators

The baseflow values (B) for the actual land cover (Esri 2023) are much higher, while the quick flow (QF) values, on the contrary, are lower compared to hypothetical cases where all natural ecosystems are replaced with bare ground or croplands (Table 3.1.B1-1). The difference between runoff values for the actual land cover and bare ground can be interpreted as the ES provided by terrestrial vegetation: B = 47.8 mm in average, and QF = -22.2 mm in average. Thus, ecosystems provide 93% of baseflow and reduce quick flow by 22%.

ES maps show that under the bare ground and cropland scenarios, baseflow is almost absent (Figure 3.1.B1-2), meaning that the existing baseflow is almost entirely provided by terrestrial ecosystems.

With the current landcover, the baseflow is on average 35% of the total flow (from 28 to 40% in different watersheds). With the bare ground scenario, the baseflow is only 3% (from 2 to 4%) (Table 3.1.B1-2; Figure 3.1.B1-3). The values of these indicators across the marzes largely mirror them for the corresponding watersheds (Figure 3.1.B1-4).

Table 3.1.B1-1. ES indicator values for Armenia under different scenarios

Scenario	Baseflow, mm (B)	Quick flow, mm (QF)	(B+QF)	Share of B in total flow, %
Land cover 2017	51.97	97.01	148.97	34.88
Land cover 2023	51.28	98.04	149.32	34.34
Bare ground scenario	3.43	120.22	123.65	2.78
Cropland scenario	3.58	124.96	128.54	2.78

²⁴ https://storage.googleapis.com/releases.naturalcapitalproject.org/invest-userguide/latest/en/seasonal_water_yield.html

185

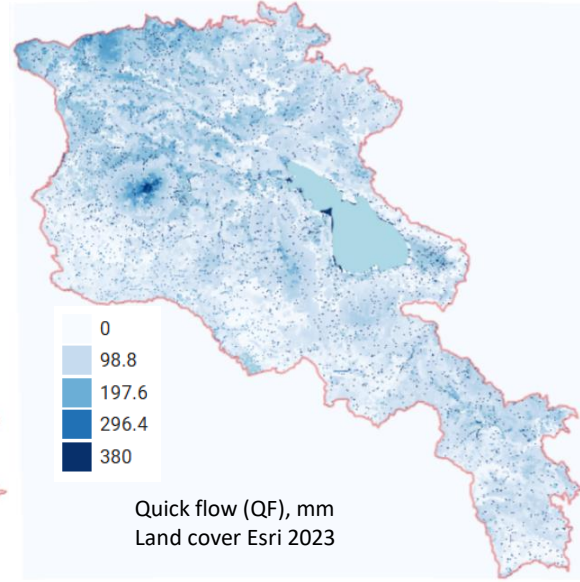
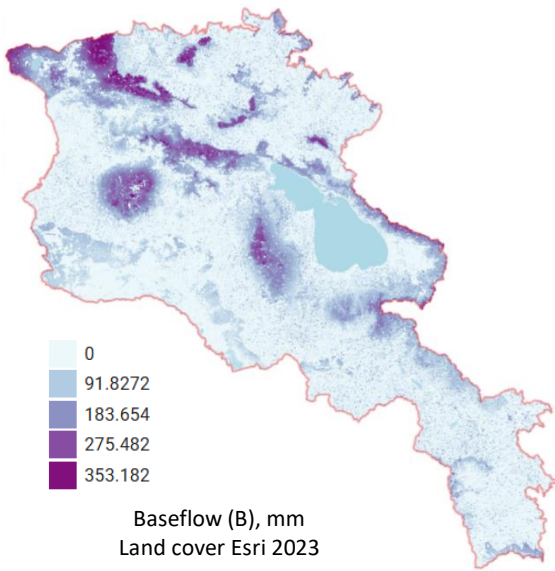

186

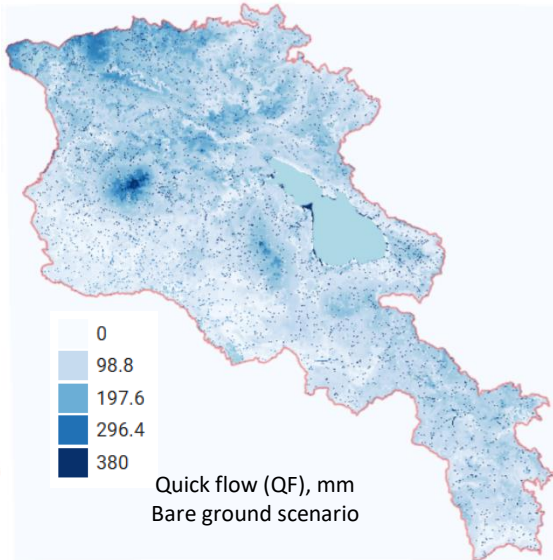
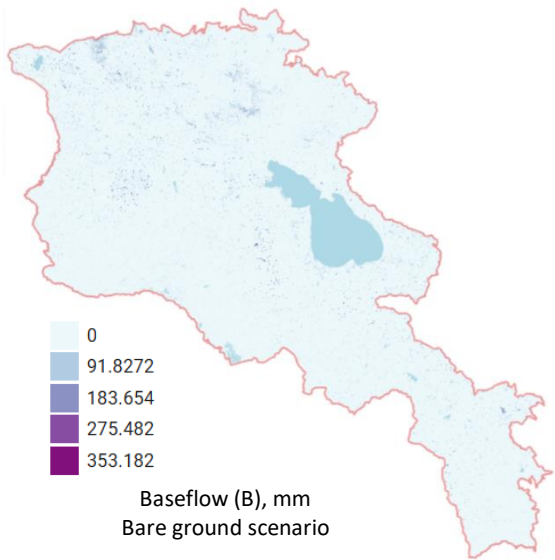

187

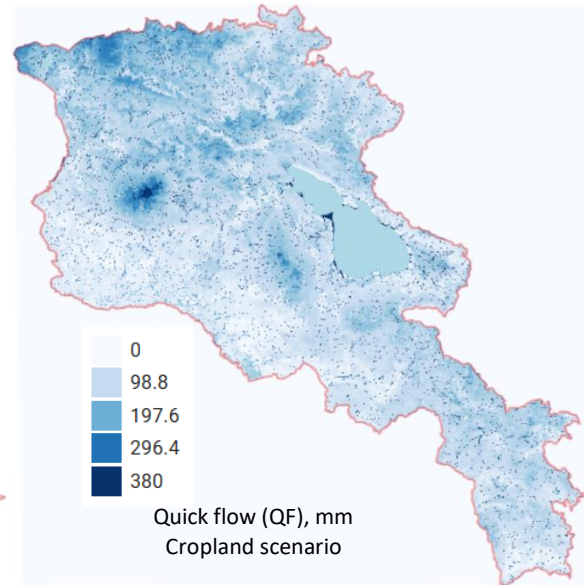
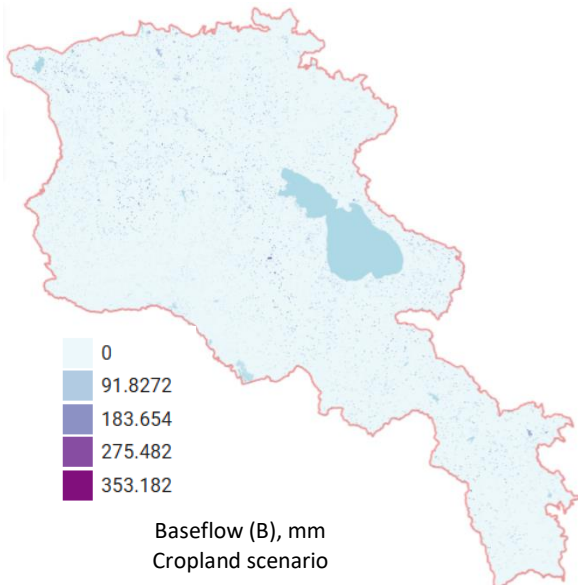

188

189

Figure 3.1.B1-2. Maps of ES indicators for different scenarios. For details see project Web GIS <https://bccarmenia.nextgis.com/>, section "Ecosystem services. Seasonal Water Yield"

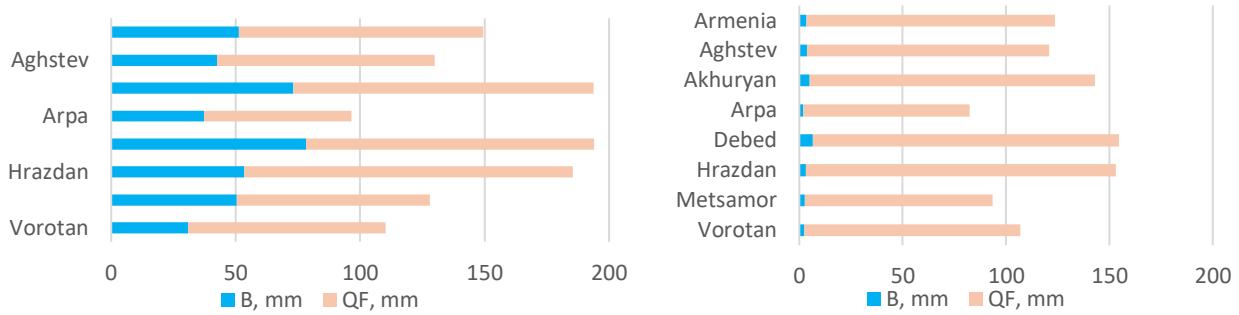

190

191

Figure 3.1.B1-3. Baseflow and quick flow under the current land cover and the bare ground scenario across watersheds

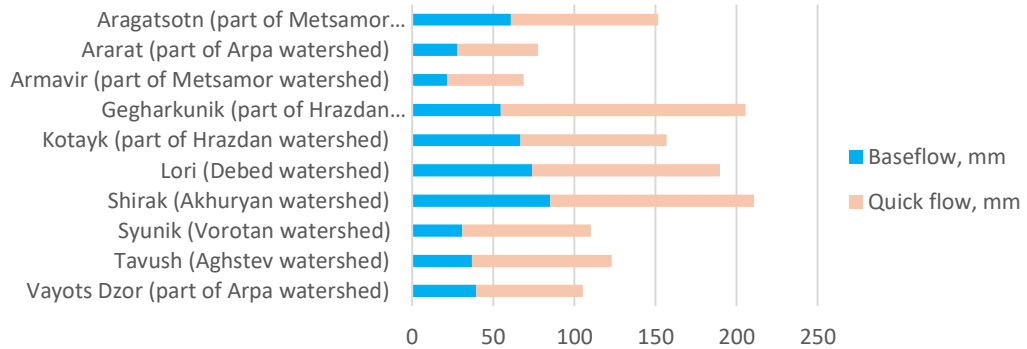

192

193

Figure 3.1.B1-4. Baseflow and quick flow under the current land cover across marzes

194

195

196

197

We estimated potential ES volume provided by terrestrial vegetation as difference between ES indicator values for the current land cover in 2023 and the bare ground scenario where all grasslands and trees were replaced by bare ground. Across watersheds, ecosystems provide 92%–95% of baseflow (Table 3.1.B1-2; Figure 3.1.B1-5) and reduce quick runoff by 13%–36% (Table 3.1.B1-2; Figure 3.1.B1-6).

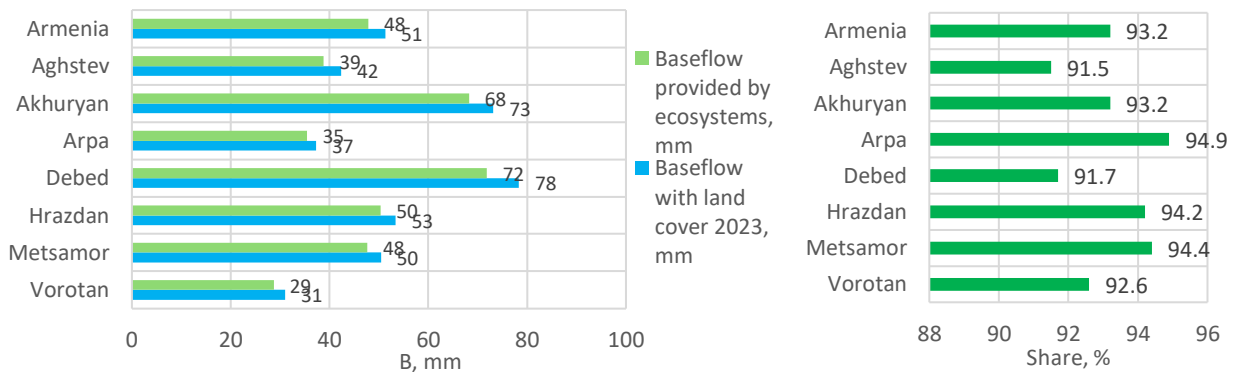

198

199

200

Figure 3.1.B1-5. Ecosystem effects on baseflow: (a) baseflow under current land cover and the component provided by ecosystems; (b) share of baseflow provided by ecosystems (%).

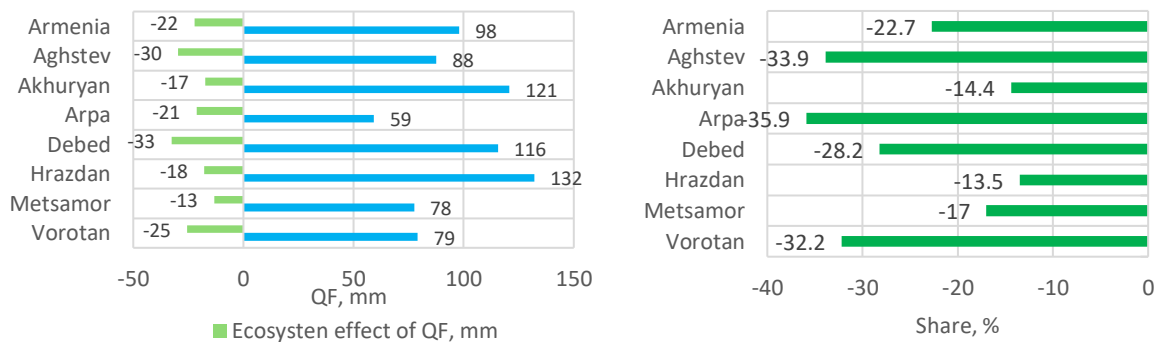

201

202

203

Figure 3.1.B1-6. Ecosystem effects on quick flow: (a) quick flow under current land cover and its part reduced by ecosystems; (b) share of quick flow reduced by ecosystems (%).

204

Table 3.1.B1-2. Potential ES indicators under the current land cover and the bare ground scenario across watersheds

Indicators		Vorotan	Metsamor	Hrazdan	Debed	Arpa	Akhuryan	Aghstev	Armenia
Land cover Esri 2023	Baseflow, mm, B_{2023}	31.0	50.4	53.4	78.3	37.3	73.2	42.4	51.3
	Quick flow, mm, QF_{2023}	79.2	77.5	132.0	115.6	59.3	120.7	87.6	98.0
	Share of B in total flow, %	28.2	39.4	28.8	40.4	38.6	37.7	32.6	34.3
Bare ground scenario	Baseflow, mm, B_{bg}	2.3	2.8	3.1	6.5	1.9	4.9	3.6	3.4
	Quick flow, mm, QF_{bg}	104.6	90.7	149.9	148.2	80.6	138.1	117.3	120.2
	Share of B in total flow, %	2.1	3.0	2.0	4.2	2.3	3.5	3.0	2.8
Ecosystem effects	Baseflow provided by ecosystems, mm $B_{eco}=B_{2023}-B_{bg}$	28.7	47.6	50.3	71.8	35.4	68.2	38.8	47.8
	Share of baseflow provided by ecosystems, % $B_{eco} * 100 / B_{2023}$	92.6	94.4	94.2	91.7	94.9	93.2	91.5	93.2
	Reduction of quickflow by ecosystems, mm $QF_{eco} = QF_{2023} - QF_{bg}$	-25.5	-13.2	-17.8	-32.6	-21.3	-17.4	-29.7	-22.2
	Share of quick flow reduced by ecosystems, % $QF_{eco} * 100 / QF_{2023}$	-32.2	-17.0	-13.5	-28.2	-35.9	-14.4	-33.9	-22.7

205

206

207

208

209

Analysis of ES indicators across vegetation types shows that the highest average baseflow values occur in alpine, subalpine and meadow-steppe zones, while forests surprisingly exhibit the lowest baseflow level. The share of baseflow provided by ecosystems and baseflow index also are lowest in forest while baseflow index is highest in desert (Figure 3.1.B1-7; Table 3.1.B1-3). These results are discussed below in the Section 3.5.

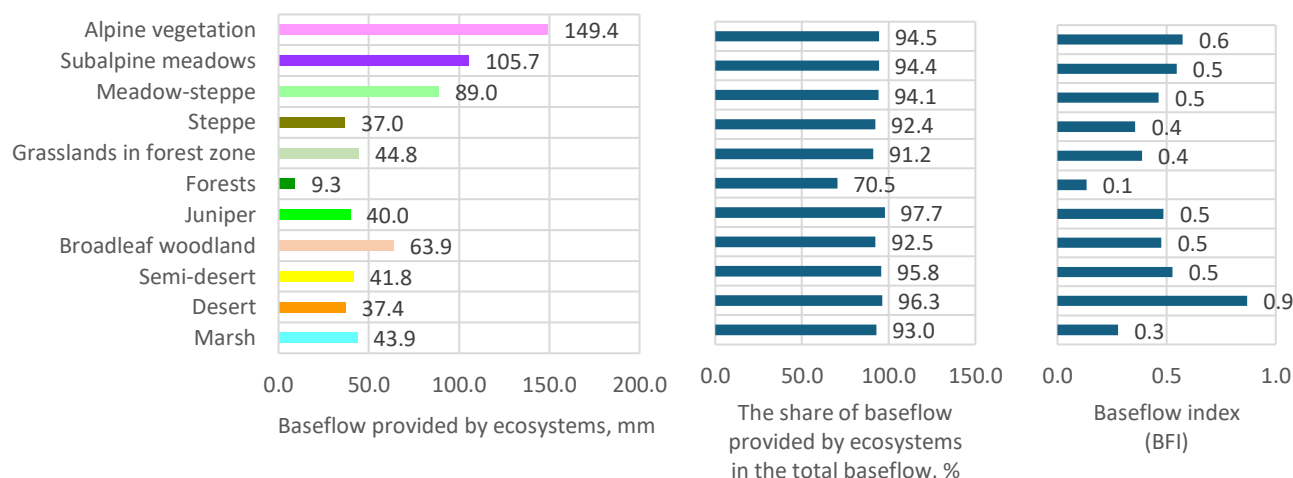

210

211

Figure 3.1.B1-7. Baseflow indicators across vegetation zones.

212

Table 3.1.B1-3. Potential ES indicators under the current land cover across vegetation types

	Alpine veg.	Sub-alpine meadows	Mea-dow-steppe	Steppe	Grasslands in forest zone	Forests	Broadleaf woodland	Juniper	Semi-desert	Desert	Marsh
Baseflow provided by ecosystems, B_{eco} , mm	149.40	105.67	89.01	36.98	44.78	9.31	63.90	39.98	41.76	37.35	43.88
Baseflow in 2023, B_{2023} , mm	158.10	111.94	94.58	40.04	49.10	13.21	65.38	43.25	43.59	38.80	47.21
Quick flow in 2023, QF_{2023} , mm	117.12	93.07	109.15	72.06	77.76	86.47	68.97	47.58	39.08	5.88	122.81
$B_{2023} + QF_{2023}$	275.21	205.01	203.73	112.10	126.86	99.68	134.35	90.83	82.67	44.68	170.02
Baseflow index BFI= $B / (B + QF)$	0.57	0.55	0.46	0.36	0.39	0.13	0.49	0.48	0.53	0.87	0.28

213

214
215
216
217
218
219
220
221
222
223
224
225

Baseflow volume

The volume of baseflow provided by ecosystems cannot be assessed directly on the basis of modelling results. Since the baseflow and quick flow values computed by the SWY model are relative measures (InVEST User Guide), the baseflow volume V_B was calculated as follows: $V_B = BFI \cdot V_{tot}$ where V_{tot} is the river discharge according to the data reported by the Government of Armenia and Armstat (Table 3.1.B1-4); BFI is baseflow index, $BFI = B / (B + QF)$, where B and QF are baseflow and quick flow values computed by SWY model. The volume of baseflow provided by ecosystems across watersheds is presented in Table 3.1.B1-5.

This analysis is approximate, because we used river flow data by watersheds and water-use data by marzes (Appendix 3.1.B-1). The boundaries of provinces and watersheds largely coincide (Section 3.1.A), which allows such a rough estimate. For watersheds that include two or three marzes, the data for those marzes were summed. Obviously, the balance should be refined in the future using data from the same EAAs.

Table 3.1.B1-4. Data on river flow

Watershed	River flow, mln of m ₃	Data source	Details
Aghstev	260	Armstat Regional Statistics handbooks 2023 https://armstat.am/en/?nid=651	-
Akhuryan	700.7	Basin management plan https://www.arlis.am/hy/acts/112336	River flow was calculated as the sum of utilizable river flow (506.2) and environmental flow (194.5).
Arpa	1177.0	Basin management plan https://www.arlis.am/hy/acts/104697	The sum of river flows of Azat, Vedi, and Arpa
Debed	960	Armstat Regional Statistics handbooks 2023 https://armstat.am/en/?nid=651	-
Hrazdan	788	Basin management plan https://www.arlis.am/hy/acts/171449	Sum of river flow (469 mln m ₃) and ecological river flow (319 mln m ₃)
Metsamor	1043.3	Basin management plans https://www.arlis.am/hy/acts/171449 https://www.arlis.am/hy/acts/112336	Total river flow was calculated as the sum of Qasagh (265.5) and Metsamor (777.8) rivers. Metsamor river flow was calculated as the sum of utilizable river flow (1,786.7) and environmental flow (106.0) excluding water available from the reach downstream of the confluence of the Araks and Akhuryan rivers (1,114.9)
Sevan	615.66	Basin management plan https://www.arlis.am/hy/acts/171479	River inflow to Lake Sevan
Vorotan	1319.6	Basin management plan https://www.arlis.am/hy/acts/106124	The sum of river flows of Southern BMA

226

Table 3.1.B1-5. The volume of baseflow provided by ecosystems across watersheds

	River flow*, millions of m ³	BFI	Baseflow, millions of m ³
Aghstev (a part of the marz Tavush)	260.00	0.33	84.78
Akhuryan (marz Shirak)	700.70	0.38	264.46
Arpa (marzes Ararat and Vayots Dzor)	1177.00	0.39	454.50
Debed (marz Lori)	960.00	0.40	387.69
Hrazdan (marz Kotayk and Yerevan City)	788	0.29	228.52
Metsamor (marzes Armavir and Aragatsotn)	1043.30	0.39	411.06
Sevan (marz Gegharkunik)	615.66	0.27	166.23
Vorotan (marz Syunik)	1319.60	0.28	371.51

227
228
229
230
231
232
233
234
235
236
237
238
239
240
241
242
243
244

A direct assessment of ES potential, supply and use for different ecosystem/vegetation types based on the modeling data obtained is not possible for the following reasons:

- As mentioned above, the model estimates of baseflow and quickflow are relative values, and the absolute volume of baseflow can only be derived from the baseflow index (BFI) and the known river flow.
- The river flow generated from areas with different vegetation types is unknown.

Therefore, this assessment was derived through the relative contribution of different vegetation types to the formation of watershed river flow, which was calculated from the model data on baseflow as follows:

1) The relative contribution of vegetation type *i* to the baseflow formation in watershed *j* was calculated as

$$SB_{ij} = B_{ij}^{norm} \times SA_{ij}$$

where B_{ij}^{norm} — baseflow (mm) from vegetation type *i* in watershed *j*, normalized to the mean baseflow (mm) in watershed *j*; SA_{ij} — share of the area of vegetation type *i* within watershed *j*.

2) Baseflow volume (millions of m³) from vegetation type *i* in watershed *j* was then defined as

$$VB_{ij} = VB_j \times SB_{ij}^{norm}$$

Where VB_j is baseflow volume in watershed *j* from the Table 3.1.A2-5; SB_{ij}^{norm} is the relative contribution of vegetation type *i* to the river flow in watershed *j*, normalized so that the sum of all vegetation types contributions within watershed *j* equals 1.

3) Baseflow volume (millions of m³) provided by vegetation type *i* in watershed *j* was then defined as

245 $VBE_{ij} = VB_{ij} \times SBE_{ij}$
 246 Where SBE_{ij} - the share of provided baseflow provided by ecosystems in total baseflow.

247 The final evaluations of baseflow volume provided by vegetation types are presented in Table 31B1-6. Intermediate
 248 calculation tables are presented in the Appendix 3.1.B-2.

249 *Table 3.1.B1-6. Baseflow volume provided by vegetation types across watersheds, millions of m³*

	Alpine vegetat ion	Sub-alpine veg.	Meadow -steppe	Steppe	Grasslands in forest zone	Fores ts	Juni- per	Broadleaf woodland	Semi-desert	Dese rt	Marsh	Total in waters heds
Aghstev	0.08	16.35	0.00	0.55	20.75	10.28	0.00	28.47	0.00	0.00	0.00	76.47
Akhuryan	33.80	94.65	71.86	47.41	0.00	0.24	0.00	0.00	0.22	0.00	3.99	252.17
Arpa	100.43	45.41	41.32	96.20	44.70	1.74	6.91	0.00	80.61	0.00	6.18	423.49
Debed	17.19	185.76	66.66	25.53	44.09	11.22	0.00	1.88	0.00	0.00	1.37	353.69
Hrazdan	41.83	47.49	41.32	25.97	43.32	2.44	0.00	0.08	12.69	0.00	0.94	216.07
Metsamor	91.88	34.47	97.68	30.75	8.44	1.42	0.00	0.00	123.33	0.00	1.94	389.90
Sevan	35.71	71.25	11.99	28.70	5.60	0.71	1.72	0.15	0.00	0.00	2.35	158.19
Vorotan	100.63	67.45	25.75	49.61	44.26	11.69	0.57	21.12	19.90	0.00	0.81	341.79
Armenia	421.56	562.83	356.57	304.71	211.15	39.74	9.20	51.68	236.75	0.00	17.58	2211.78

250 For Armenia as a whole, the largest volume of baseflow is provided by subalpine meadows, followed by alpine
 251 vegetation, various steppe types, and semidesert. Meadows within the forest zone also make a substantial contribution.
 252 The remaining vegetation types, including forests, contribute only a minor share of baseflow (Figure 3.1.B1-8).
 253

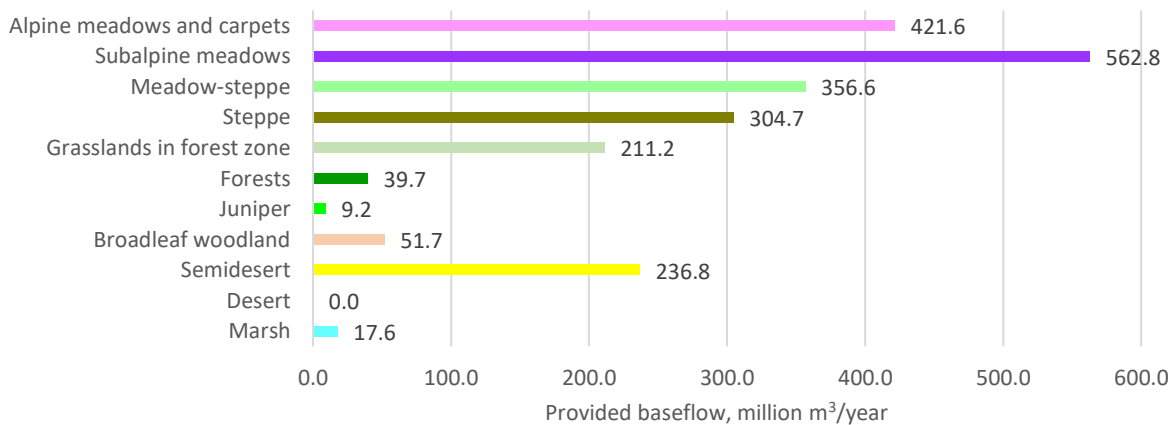

254 *Figure 3.1.B1-8. The volume of baseflow provided by different vegetation types in Armenia*
 255

256 The largest volumes of baseflow are provided by the ecosystems of the Arpa, Debed, Metsamor, and Vorotan basins,
 257 and the smallest by the Aghstev basin (Figure 31B1-9b). Alpine vegetation is most important for baseflow provision in the
 258 Arpa and Vorotan basins; subalpine vegetation—in the Debed basin; steppe—in the Arpa basin; and semidesert—in the
 259 Metsamor basin (Figure 31B1-9a).

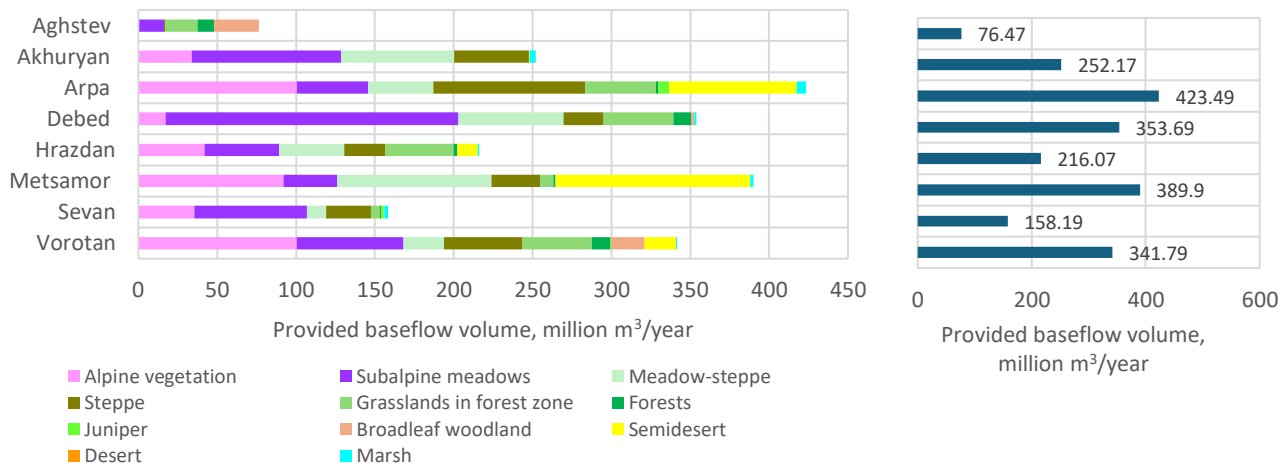

260 *Figure 3.1.B1-9. The volume of baseflow provided by different vegetation types (a) and total values across watersheds (b)*
 261

262 **3.1.B2. ES potential–supply–use balance**

263 Water use nowhere exceeds the river flow. The water-use figures are closest to river flow in the basins of Metsamor
 264 and Hrazdan. The overwhelming majority of water consumption is accounted for by the agriculture, fisheries, and
 265 forestry, which underscores the importance of assessing the ES of baseflow provision. In two watersheds —Metsamor
 266 and Hrazdan—water consumption exceeds baseflow volume, provided by ecosystems (Table 3.1.B2-1; Figure 3.1.B2-1
 267 a,b). In the Metsamor and Hrazdan watersheds, baseflow provides 63% and 54% of agricultural water consumption,
 268 respectively. In the other watersheds baseflow exceeds water consumption by many times (Figure 3.1.B2-1 c). The water-
 269 use data for Tavush marz used in the analysis pertain to an area larger than the Aghstev River watershed for which river
 270 flow data are available. Therefore, in reality the total river flow from the entire area exceeds water consumption even
 271 more than indicated by these results.

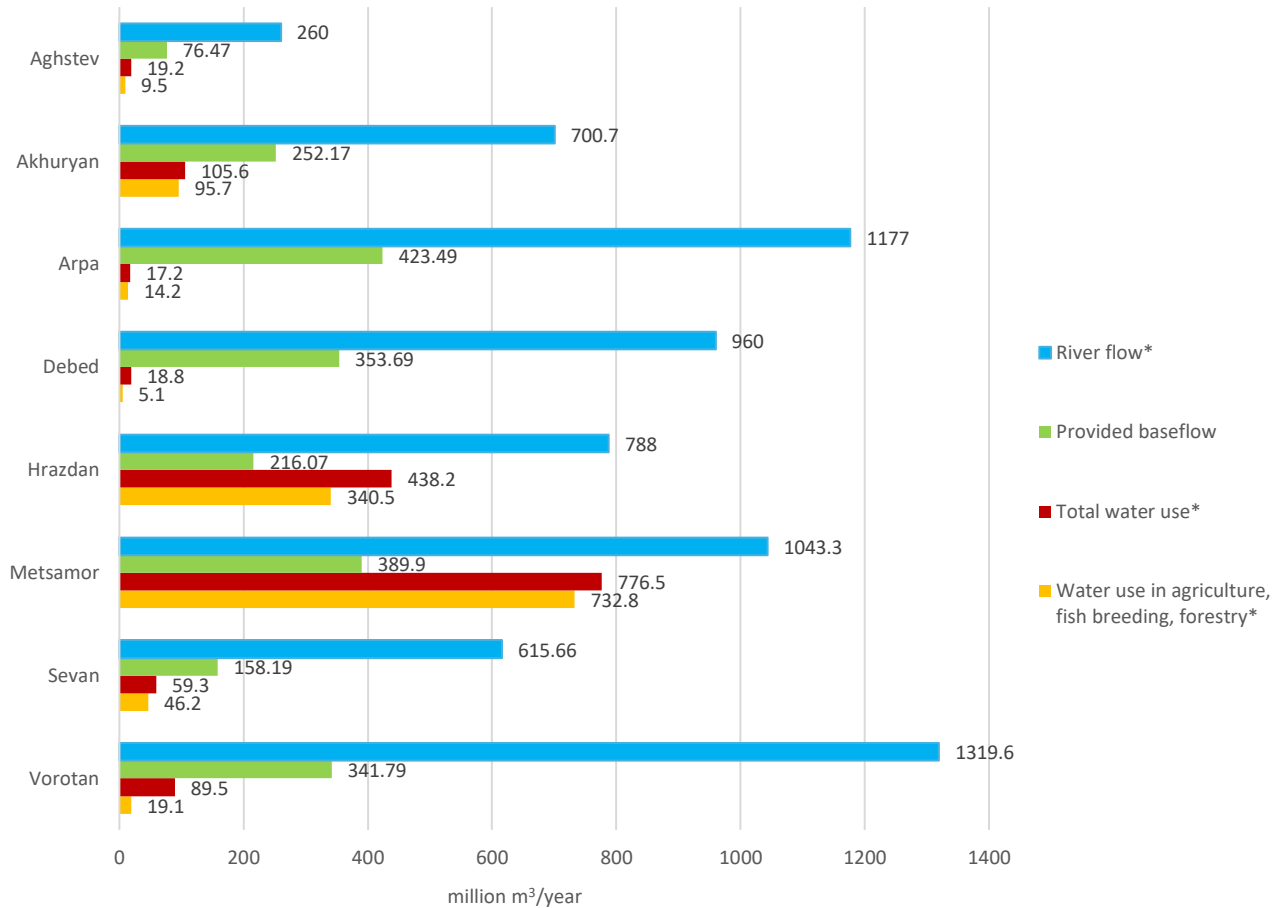

272

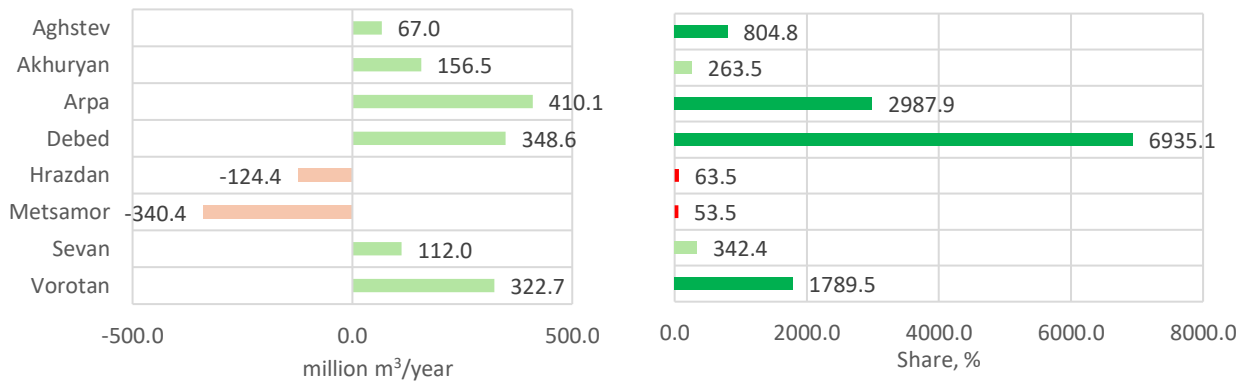

273

274 *Figure 3.1.B2-1. ES potential–use balance of ES: (a) river flow, baseflow and water consumption across watersheds (**
 275 *data reported by Armstat and the Government); (b) Difference between provided baseflow volume and water*
 276 *consumption in agriculture, fishery and forestry; (c) Share of provided baseflow in agriculture, fisheries and forestry*
 277 *water consumption (%).*

278

Table 3.1.B2-1. ES potential–use balance of ES across watersheds

	Water use in agriculture, fish breeding, forestry*, million m ³ /year	Total water use*, million m ³ /year	Provided baseflow, million m ³ /year	River flow*, million m ³ /year	Difference between provided baseflow volume and water consumption in agriculture etc., million m ³ /year	Share of provided baseflow in agriculture etc. water consumption (%)
Aghstev (a part of the Tavush marz)	9.5	19.2	76.47	260.00	322.7	1789.5
Akhuryan (Shirak marz)	95.7	105.6	252.17	700.70	112.0	342.4
Arpa (Ararat and Vayots Dzor marzes)	14.2	17.2	423.49	1177.00	-340.4	53.5
Debed (Lori marz)	5.1	18.8	353.69	960.00	-124.4	63.5
Hrazdan (Kotayk marz and Yerevan City)	340.5	438.2	216.07	788	348.6	6935.1
Metsamor (Armavir and Aragatsotn marzes)	732.8	776.5	389.90	1043.30	410.1	2987.9
Sevan (Gegharkunik marz)	46.2	59.3	158.19	615.66	156.5	263.5
Vorotan (Syunik marz)	19.1	89.5	341.79	1319.60	67.0	804.8

*Data reported by Armstat: Environment and Natural Resources in the Republic of Armenia for 2022, <https://armstat.am/en/?nid=82&id=2603>

279

280

281

282

283

284

285

286

287

288

289

To assess the potential-use balance across vegetation types, we estimated the demand for baseflow, disaggregated by vegetation type, required to satisfy current water use (how much baseflow ecosystems must provide to meet current water-use volumes) was estimated as $D_{ij}=WU_j \times SB_{ij}^{norm}$ —where WU_j is total water use, and SB_{ij}^{norm} - the relative contribution of vegetation types to baseflow formation computed above. This allowed us to estimate also actual ES flow (supply=use), unused ES potential and unmet demand (provided baseflow volume minus demand) following the recommendations of the INCA project (Vallecillo et al., 2019) (Table 31B2-3 and Figure 31B2-2). In the Metsamor and Hrazdan basins, all vegetation types—and, for Armenia as a whole, the semidesert ecosystems—provide baseflow volumes that are lower than water consumption. In all other cases, the volume of provided baseflow exceeds total water consumption.

290

291

292

293

294

295

296

In line with the SEEA-EA understanding of ES supply, the volumes of baseflow equal to its use constitute the supplied ES. However, in the Metsamor and Hrazdan watersheds, water consumption exceeds baseflow; therefore, the demand is unmet there. According to the SEEA EA approach, in the final ES accounting table the “unmet demand” values should be replaced with the volumes of baseflow provided by ecosystems, while the indicators of ES use should be made equal to the supplied ES. The SEEA table format does not require reporting demand for ES; however, for clarity we highlighted in red cases where water use exceeds the ES supply-use — in the Metsamor and Hrazdan watersheds and for total water use in Armenia (Table 3.1.B2-4).

297

298

299

300

The assessment of the ES potential–use balance, carried out in accordance with the INCA recommendations, shows that in the Arpa, Debed and Vorotan watersheds there is a substantial unused potential of baseflow, whereas the ecosystems of the Hrazdan and Metsamor watersheds do not meet the demand for water consumption (unmet demand) (Figure 3.1.B2-2).

301

302

303

In conclusion, it should be emphasized that this assessment of ES potential-supply-use balance was made for methodological purposes, to demonstrate different approaches to assessing the balance. It is obvious that water demand is satisfied not only by baseflow but by total river flow, which in all watersheds exceeds current water consumption.

304

305

Table 31B2-3. ES indicators across watersheds and vegetation types, million m³/year (according to INKA recommendations)

		Alpine vegetation	Subalpine meadows	Meadow-steppe	Steppe	Grasslands in forest	Forests	Juniper	Broadleaf woodland	Semidesert	Desert	Marsh	Total in watersheds
Potential ES: baseflow volume provided by ecosystems	Aghstev	0.08	16.35	0.00	0.55	20.75	10.28	0.00	28.47	0.00	0.00	0.00	76.47
	Akhuryan	33.80	94.65	71.86	47.41	0.00	0.24	0.00	0.00	0.22	0.00	3.99	252.17
	Arpa	100.43	45.41	41.32	96.20	44.70	1.74	6.91	0.00	80.61	0.00	6.18	423.49
	Debed	17.19	185.76	66.66	25.53	44.09	11.22	0.00	1.88	0.00	0.00	1.37	353.69
	Hrazdan	41.83	47.49	41.32	25.97	43.32	2.44	0.00	0.08	12.69	0.00	0.94	216.07
	Metsamor	91.88	34.47	97.68	30.75	8.44	1.42	0.00	0.00	123.33	0.00	1.94	389.90
	Sevan	35.71	71.25	11.99	28.70	5.60	0.71	1.72	0.15	0.00	0.00	2.35	158.19
	Vorotan	100.63	67.45	25.75	49.61	44.26	11.69	0.57	21.12	19.90	0.00	0.81	341.79
Armenia	421.56	562.83	356.57	304.71	211.15	39.74	9.20	51.68	236.75	0.00	17.58	2211.78	

Baseflow demand	Aghstev	0.02	4.15	0.00	0.13	5.32	3.04	0.00	6.55	0.00	0.00	0.00	19.2
	Akhuryan	14.52	39.13	29.82	20.23	0.00	0.16	0.00	0.00	0.10	0.00	1.65	105.6
	Arpa	4.26	1.84	1.54	4.04	1.83	0.10	0.12	0.06	3.19	0.01	0.21	17.2
	Debed	0.96	9.55	3.53	1.32	2.38	0.89	0.00	0.10	0.00	0.00	0.08	18.8
	Hrazdan	83.65	93.94	83.09	54.63	87.27	7.36	0.00	0.17	26.11	0.00	1.97	438.2
	Metsamor	137.02	52.80	149.13	48.10	10.61	5.05	0.00	0.00	370.28	0.00	3.52	776.5
	Sevan	13.21	26.58	4.62	10.87	2.16	0.38	0.63	0.06	0.00	0.00	0.92	59.3
	Vorotan	25.86	17.82	6.78	13.29	11.74	3.53	0.15	5.26	4.88	0.00	0.21	89.5
	Armenia	279.50	245.81	278.52	152.61	121.31	20.51	0.90	12.20	404.56	0.01	8.56	1524.3
Actual flow (supply=use)	Aghstev	0.02	4.15	0.00	0.13	5.32	3.04	0.00	6.55	0.00	0.00	0.00	19.21
	Akhuryan	14.52	39.13	29.82	20.23	0.00	0.16	0.00	0.00	0.10	0.00	1.65	105.61
	Arpa	4.26	1.84	1.54	4.04	1.83	0.10	0.12	0.00	3.19	0.00	0.21	17.13
	Debed	0.96	9.55	3.53	1.32	2.38	0.89	0.00	0.10	0.00	0.00	0.08	18.81
	Hrazdan	41.83	47.49	41.32	25.97	43.32	2.44	0.00	0.08	12.69	0.00	0.94	216.07
	Metsamor	91.88	34.47	97.68	30.75	8.44	1.42	0.00	0.00	123.33	0.00	1.94	389.90
	Sevan	13.21	26.58	4.62	10.87	2.16	0.38	0.63	0.06	0.00	0.00	0.92	59.42
	Vorotan	25.86	17.82	6.78	13.29	11.74	3.53	0.15	5.26	4.88	0.00	0.21	89.52
	Armenia	192.54	181.02	185.29	106.60	75.19	11.95	0.90	12.05	144.19	0.00	5.95	915.68
Unused potential/ unmet demand	Aghstev	0.06	12.20	0.00	0.42	15.43	7.24	0.00	21.92	0.00	0.00	0.00	57.26
	Akhuryan	19.28	55.52	42.04	27.18	0.00	0.08	0.00	0.00	0.12	0.00	2.34	146.56
	Arpa	96.17	43.57	39.78	92.16	42.87	1.64	6.79	-0.06	77.42	-0.01	5.97	406.29
	Debed	16.23	176.21	63.13	24.21	41.71	10.33	0.00	1.78	0.00	0.00	1.29	334.88
	Hrazdan	-41.82	-46.46	-41.77	-28.66	-43.95	-4.92	0.00	-0.09	-13.42	0.00	-1.03	-222.13
	Metsamor	-45.14	-18.33	-51.45	-17.35	-2.17	-3.63	0.00	0.00	-246.95	0.00	-1.58	-386.61
	Sevan	22.51	44.68	7.36	17.84	3.44	0.34	1.09	0.09	0.00	0.00	1.43	98.76
	Vorotan	74.77	49.63	18.97	36.32	32.52	8.16	0.42	15.86	15.02	0.00	0.60	252.27
	Armenia	142.06	317.02	78.05	152.11	89.84	19.23	8.29	39.49	-167.81	-0.01	9.02	687.29

306

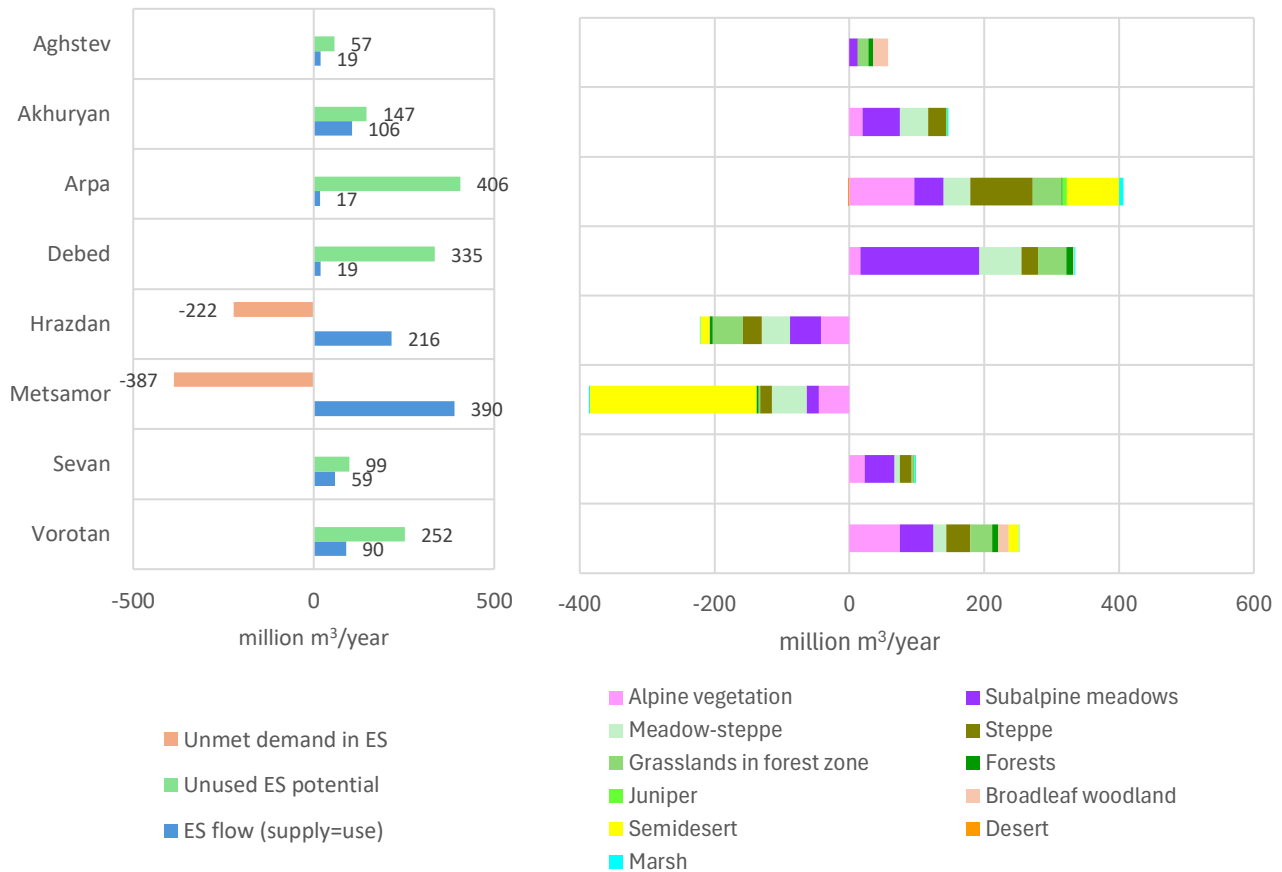

307

308

309

Figure 3.1.B2-2. Baseflow supply, unused ES potential and unmet demand in ES: a) across watersheds; b) unused ES potential and unmet demand by ecosystem type

310
311

Table 3.1.B2-4. Supply-use table for ES of baseflow maintenance in format recommended by SEEA EA. The figures in parentheses indicate the volumes of water use that exceed the supplied ES, i.e., unmet demand.

		Drinking	Industrial, domestic and construction	Agriculture, fish breeding and forestry	Total ES use	Alpine vegetation	Subalpine meadows	Meadow-steppe	Steppe	Grasslands in forest zone	Forests	Juniper	Broadleaf woodland	Semidesert	Desert	Marsh	Total ES supply	
Aghstev	Supply					0	4	0	0	5	3	0	7	0	0	0	19	
	Use	8	1	10	19													
Akhuryan	Supply					15	39	30	20	0	0	0	0	0	0	0	2	106
	Use	8	2	96	106													
Arpa	Supply					4	2	2	4	2	0	0	0	3	0	0	17	
	Use	2	1	14	17													
Debed	Supply					1	10	4	1	2	1	0	0	0	0	0	19	
	Use	10	4	5	19													
Hrazdan	Supply					42	47	41	26	43	2	0	0	13	0	1	216	
	Use	28	19	169	216													
	Demand	57 (13%)	41 (9%)	341(78%)	438													
Metsamor	Supply					92	34	98	31	8	1	0	0	123	0	2	390	
	Use	12	12	367	390													
	Demand	23 (3%)	21 (3%)	733(94%)	777													
Sevan	Supply					13	27	5	11	2	0	1	0	0	0	1	59	
	Use	12	1	46	59													
Vorotan	Supply					26	18	7	13	12	4	0	5	5	0	0	90	
	Use	7	63	19	90													
Armenia	Supply					193	181	185	107	75	12	1	12	144	0	6	916	
	Use	46	55	815	916													
	Demand	133 (5%)	140 (6%)	2150 (89%)	2422													

312

313

3.1.B3. ES changes from 2017 to 2023

314

We assessed only changes in ES potential, since we have no data on ES use for 2017.

315

Assessment of ES changes based on the 2017 and 2023 modelled baseflow maps

316

From the modeled ES maps, we can directly assess only the changes in the relative indicators of baseflow and quickflow, expressed in mm. All changes identified are determined only by changes in the landcover (Section 2.2.B). Weather and climate changes are not taken into account. The maps show that the changes are sporadic and oppositely directed (Figure 31B3-1). Nevertheless, overall, they can be characterized as negative. In cases where ES indicators changed significantly, baseflow (B) decreased while quick flow (QF) increased. This means that the ability of terrestrial ecosystems to sustain baseflow during dry periods is declining. The only exception is the Arpa basin, where B has increased. The most significant negative changes occurred in the Shirak province and the Akhuryan watershed corresponding to land cover changes in the Shirak province. The reason is the expansion of the croplands at the expense of the grasslands in the Shirak province (Section 2.2).

324

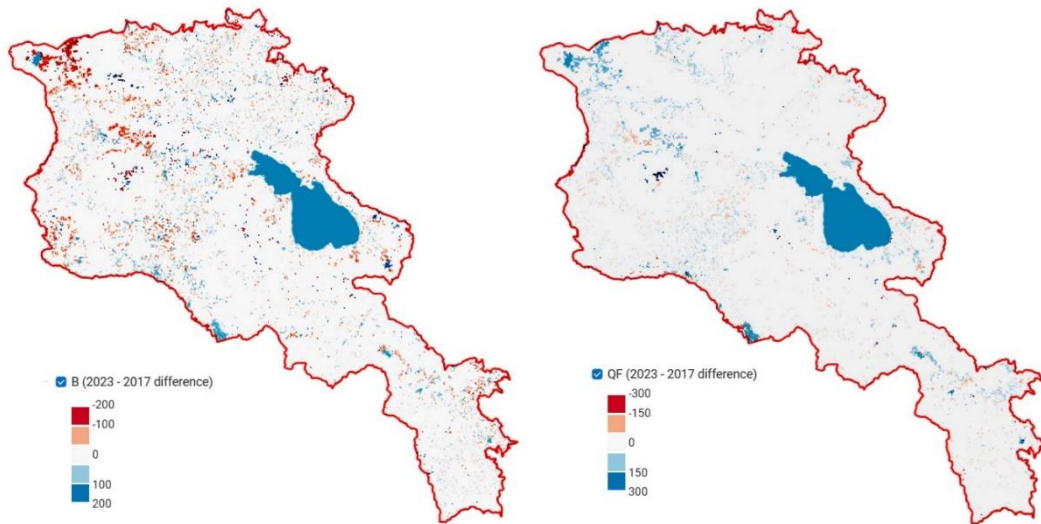

325

326

Figure 3.1.B3-1. Changes in baseflow (a) and quickflow (b) from 2017 to 2023, mm. For details see project Web GIS <https://bccarmenia.nextgis.com/>, section "Ecosystem services. Seasonal Water Yield"

327

328 The most notable changes across watersheds and marzes are a decrease in baseflow and an increase in quickflow.
 329 These negative changes are most pronounced in the Akhuryan and Metsamor watersheds and in the marzes Shirak and
 330 Aragatsotn. A slight increase in baseflow is observed in the Arpa and Aghstev watersheds and in Ararat marz (Table 3.1.B3-
 331 1; Figures 3.1.B3-2 and 3.1.B3-3).

332 Table 3.1.B3-1. Changes in baseflow and quick flow from 2017 to 2023 across watersheds and marzes

EAA	Baseflow, mean				Quick flow, mean				
	B 2017, mm	B 2023, mm	Change in B, mm	Change in B, % relative to 2017	QF 2017, mm	QF 2023, mm	Change in QF, mm	Change in QF, % relative to 2017	
Watersheds	Aghstev	42.1	42.4	0.2	0.6	87.3	87.6	0.3	0.3
	Akhuryan	79.0	73.2	-5.9	-7.4	116.6	120.7	4.1	3.5
	Arpa	37.0	37.3	0.2	0.7	59.3	59.3	0.0	0.0
	Debed	78.6	78.3	-0.3	-0.4	114.3	115.6	1.3	1.1
	Hrazdan	53.5	53.4	0.0	-0.1	131.4	132.0	0.6	0.5
	Metsamor	51.7	50.4	-1.2	-2.4	75.8	77.5	1.7	2.3
	Vorotan	31.0	31.0	0.0	0.1	78.6	79.2	0.5	0.7
Provinces	Aragatsotn	62.5	61.0	-1.5	-2.5	88.5	90.5	2.0	2.2
	Ararat	27.6	28.1	0.5	1.7	49.5	49.6	0.1	0.3
	Armavir	22.2	21.9	-0.3	-1.3	46.2	46.8	0.6	1.2
	Gegharkunik	54.6	54.5	-0.1	-0.1	150.5	151.1	0.6	0.4
	Kotayk	66.4	66.7	0.3	0.4	89.8	90.3	0.5	0.6
	Lori	74.1	74.0	-0.2	-0.2	114.5	115.8	1.3	1.2
	Shirak	91.3	85.1	-6.2	-6.8	121.3	125.7	4.4	3.6
	Syunik	30.9	30.9	0.0	0.1	78.6	79.1	0.5	0.7
	Tavush	36.7	36.9	0.1	0.3	86.2	86.3	0.1	0.1
Vayots Dzor	39.3	39.4	0.1	0.3	66.0	66.0	0.0	0.0	
Armenia	52.0	51.3	-0.7	-1.3	97.0	98.0	1.0	1.1	

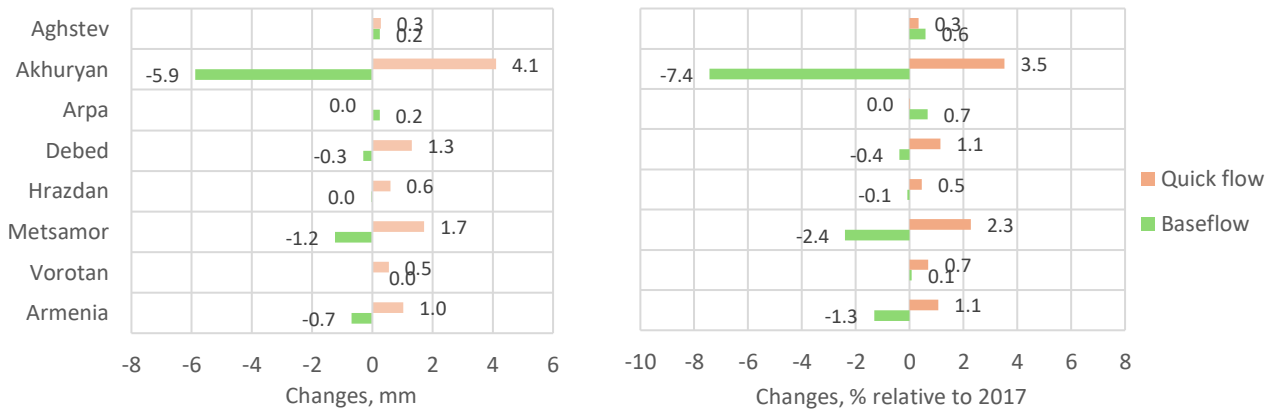

333
 334 Figure 3.1.B3-2. Changes in baseflow and quickflow from 2017 to 2023 in absolute (a) and relative (b) indicators across
 335 watersheds

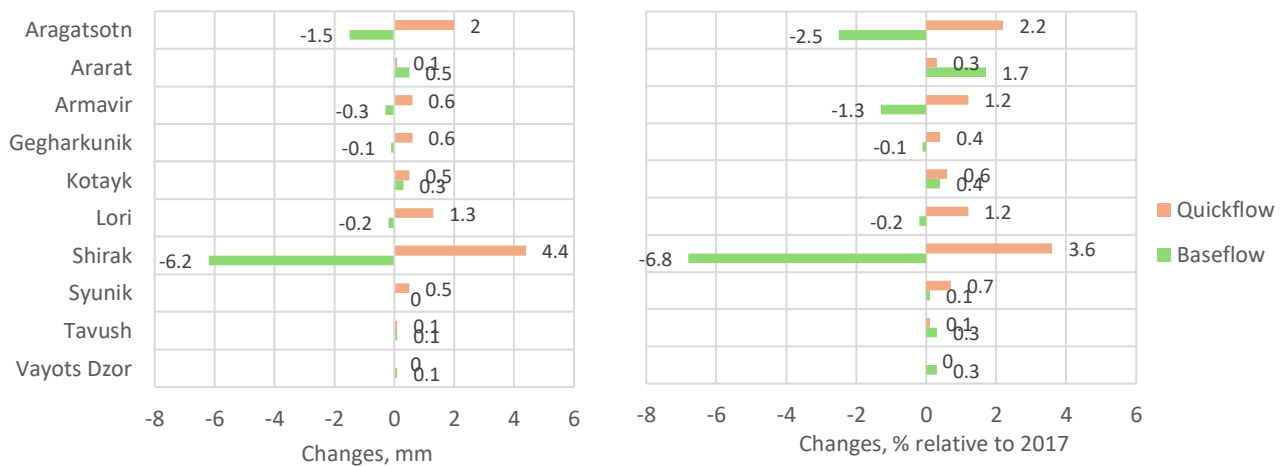

336
 337 Figure 3.1.B3-3. Changes in baseflow and quickflow from 2017 to 2023 in absolute (a) and relative (b) indicators across
 338 marzes

339
340
341
342
343
344
345
346
347
348
349
350
351
352
353
354
355

Assessment of changes in baseflow volume based on the changes in area of vegetation types

At this stage, changes in the volume of ecosystem-provided baseflow can only be assessed via changes in the area of those ecosystem types. From the maps of modeled baseflow for 2017 and 2023, this is difficult: we don't know actual water flow volumes for the areas that changed, and converting relative model baseflow indicator (in mm) into total baseflow volume is challenging.

Changes in the volume of baseflow provided by ecosystems can be assessed using the indicator of ecosystem-provided baseflow per 1 km² (Table 3.1.B3-2), derived from the previously computed values of this indicator for vegetation types (Table 3.1.B1-6), together with their area and its changes between 2017 and 2023 (Table 2.3.C-2). This indicator makes it possible to calculate the data for the table recording the dynamics of the ES potential/capacity (Table 3.1.B3-3).

With respect to changes in ES potential/capacity, the same comment applies as for changes in ecosystem extent (Section 2.3.A). Additions to ecosystem area resulting from transitions out of croplands or built-up areas do not possess full ecosystem functionality. Therefore, the closing ES capacity is defined more by the extent of ecosystems that remained untransformed during the reporting period than by the total closing ecosystem area.

The ES potential of meadow-steppes decreased the most—by 35.6 million m³; the potential of steppe ecosystems also declined substantially. The potential of grasslands within the forest zone increased slightly. Changes in the ES potential of other vegetation types were less pronounced (Table 3.1.B3-3; Figure 3.1.B3-4).

Table 3.1.B3-2. Baseflow volume provided by vegetation types, million m³/km²

	Alpine vegetation	Subalpine meadows	Meadow-steppe	Steppe	Grassl. in forest zone	Forests	Juniper	Broadleaf woodland	Semi-desert	Desert	Marsh	Total in watershed ^s
Provided baseflow volume, millions of m ³	421.6	562.8	356.6	304.7	211.2	39.7	9.2	51.7	236.8	0.00	17.6	2211.8
Area km ²	1652.2	4280.1	2557.1	5243.1	2896.5	3129.0	130.3	703.9	2459.2	6.9	281.0	23339.3
Provided baseflow volume, millions of m ³ /km ²	0.26	0.13	0.14	0.06	0.07	0.01	0.07	0.07	0.10	0.00	0.06	0.09

356

Table 3.1.B3-3. Accounting table for the ES capacity for 2017 and 2023, million m³/year

	Alpine vegetation	Subalpine meadows	Meadow-steppe	Steppe	Grasslands in forest zone	Forests	Juniper	Broadleaf woodland	Semi-desert	Desert	Marsh	Total
Opening ES capacity in 2017	156.0	407.5	269.3	515.8	270.1	12.2	67.3	234.9	0.7	22.4	310.8	2267.1
Additions to ES capacity	0.5	7.3	3.3	18.3	25.5	0.2	5.4	18.3	0.0	1.7	21.9	102.3
Managed/ Unmanaged	NA											
Reductions in ES capacity	0.3	7.9	27.4	38.3	21.0	0.1	6.7	19.3	0.0	2.3	35.1	158.4
Managed/ Unmanaged	NA											
Net change in ES capacity	0.2	-0.7	-24.1	-20.0	4.4	0.1	-1.2	-1.0	0.0	-0.6	-13.2	-56.1
Closing ES capacity in 2024	156.1	406.9	245.2	495.9	274.5	12.3	66.1	233.8	0.6	21.9	297.6	2211.0
Additional row – see Section 2.3.C												
Closing ES capacity in 2024 of eco-systems unconverted since 2017	427.2	548.2	357.3	302.4	184.0	29.1	8.9	44.8	227.5	0.0	12.8	2142.1

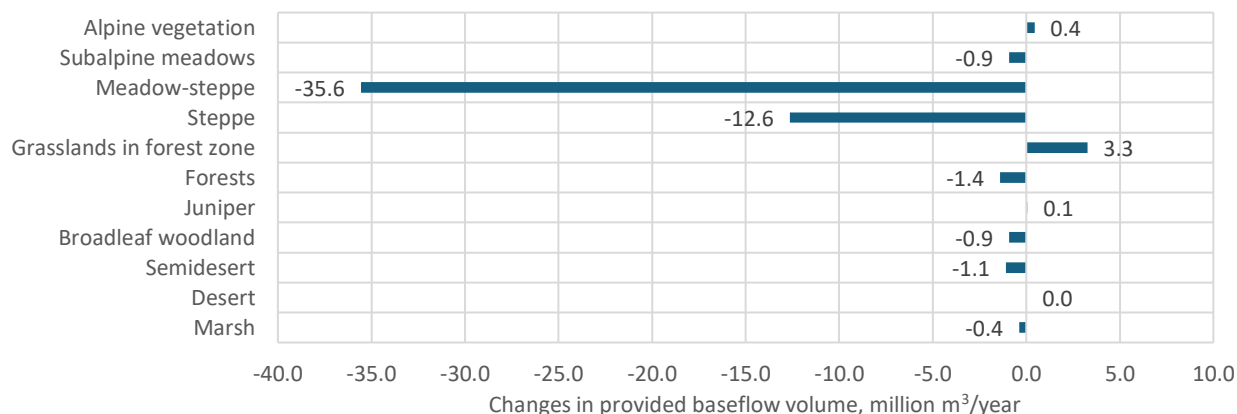

357
358

Figure 3.1.B3-4. Changes in baseflow volume, provided by different vegetation types

359 The analogous assessments for watersheds can be produced in the same way, if land-cover classes transition matrices
 360 for watersheds are available for the reporting period. Alternatively, the assessment can be obtained by a simpler
 361 approach that, however, shows only the net change in ES capacity/potential without separating gains and losses over the
 362 reporting period. Changes in the volume (million m³) of baseflow provided by ecosystems were calculated as BE₂₀₂₃ –
 363 BE₂₀₁₇, where BE₂₀₂₃ and BE₂₀₁₇ are the volumes of provided baseflow in 2023 and 2017, respectively. BE₂₀₂₃ values are
 364 taken from Table 3.1.B2-3, while BE₂₀₁₇ was calculated as BE₂₀₂₃ × E_{2017%}, where E_{2017%} is the extent of each vegetation
 365 type in 2017 relative to 2023 (E₂₀₁₇ / E₂₀₂₃ × 100, derived from the data in Table 2.3.D-1). The results across watersheds
 366 are presented in Table 3.1.B3-4.

367 The volume of baseflow provided by ecosystems decreased most strongly in the Akhuryan watershed due to the
 368 reduction in the area of steppes and subalpine meadows. Significant reductions in ecosystem-provided baseflow also
 369 occurred in the Debed and Metsamor watersheds—again as a result of shrinking steppe area. In the Vorotan watershed,
 370 substantial changes likewise occurred, but the effects of declines in steppe and forest area and increases in grasslands
 371 within the forest zone and in subalpine meadows largely offset one another (Figure 31B3-4). For relative indicators, these
 372 changes exactly mirror the changes in the area of vegetation types (Table 2.3.D-1), since they are calculated from those
 373 areas.

374 *Table 3.1.B3-4. Changes in baseflow provided by vegetation types from 2017 to 2023 across watersheds*

		Alpine vegetation	Subalpine meadows	Meadow- steppe	Steppe	Grasslands in forest zone	Forests	Juniper	Broadleaf Woodland	Semidesert	Desert	Marsh
Extent in 2017, relative to 2023	Aghstev	1.00	0.97	0.00	0.91	1.00	0.99	0.00	1.02	0.00	0.00	0.00
	Akhuryan	1.00	1.06	1.24	1.11	0.00	0.98	0.00	0.00	1.01	0.00	1.39
	Arpa	1.00	1.00	1.00	1.00	0.98	1.21	1.00	1.01	0.98	1.03	0.93
	Debed	0.98	1.00	1.08	1.14	1.05	0.98	0.00	1.20	0.00	0.00	1.01
	Hrazdan	0.96	1.02	0.85	1.12	0.99	0.96	0.99	1.01	0.99	0.00	1.00
	Metsamor	1.00	1.01	1.12	0.99	0.99	1.13	0.00	0.00	1.01	0.00	0.93
	Sevan	1.02	0.78	0.95	1.04	1.00	1.01	1.05	1.07	1.02	1.00	0.83
	Vorotan	0.99	0.98	1.08	1.03	0.92	1.25	0.94	0.96	1.00	0.00	1.21
Baseflow volume provided by ecosystems in 2023, millions of m3	Aghstev	0.08	16.35	0.00	0.55	20.75	10.28	0.00	28.47	0.00	0.00	0.00
	Akhuryan	33.80	94.65	71.86	47.41	0.00	0.24	0.00	0.00	0.22	0.00	3.99
	Arpa	100.43	45.41	41.32	96.20	44.70	1.74	6.91	0.00	80.61	0.00	6.18
	Debed	17.19	185.76	66.66	25.53	44.09	11.22	0.00	1.88	0.00	0.00	1.37
	Hrazdan	41.83	47.49	41.32	25.97	43.32	2.44	0.00	0.08	12.69	0.00	0.94
	Metsamor	91.88	34.47	97.68	30.75	8.44	1.42	0.00	0.00	123.33	0.00	1.94
	Sevan	35.71	71.25	11.99	28.70	5.60	0.71	1.72	0.15	0.00	0.00	2.35
	Vorotan	100.63	67.45	25.75	49.61	44.26	11.69	0.57	21.12	19.90	0.00	0.81
Armenia	421.56	562.83	356.57	304.71	211.15	39.74	9.20	51.68	236.75	0.00	17.58	
Baseflow volume provided by ecosystems in 2017, millions of m3	Aghstev	0.08	15.90	0.00	0.50	20.85	10.19	0.00	29.14	0.00	0.00	0.00
	Akhuryan	33.70	100.09	88.97	52.41	0.00	0.24	0.00	0.00	0.23	0.00	5.53
	Arpa	100.43	45.39	41.32	96.04	43.93	2.10	6.90	0.00	78.71	0.00	5.72
	Debed	16.77	186.46	71.95	29.14	46.43	11.05	0.00	2.25	0.00	0.00	1.38
	Hrazdan	41.61	45.57	40.85	26.27	43.08	2.74	0.00	0.08	13.14	0.00	0.98
	Metsamor	91.79	34.82	109.67	30.34	8.34	1.60	0.00	0.00	124.55	0.00	1.81
	Sevan	35.66	71.91	12.59	30.82	5.69	0.74	1.71	0.12	0.00	0.00	2.38
	Vorotan	99.60	65.85	27.92	50.91	40.61	14.60	0.54	20.38	19.97	0.00	0.99
Armenia	419.63	566.00	393.28	316.43	208.93	43.25	9.15	51.97	236.59	0.00	18.81	
Changes in provided baseflow from 2023 to 2017, millions of m3	Aghstev	0.00	0.44	0.00	0.05	-0.10	0.09	0.00	-0.67	0.00	0.00	0.00
	Akhuryan	0.11	-5.44	-17.12	-5.01	0.00	0.01	0.00	0.00	0.00	0.00	-1.54
	Arpa	0.00	0.02	0.00	0.15	0.77	-0.36	0.01	0.00	1.90	0.00	0.45
	Debed	0.42	-0.70	-5.30	-3.62	-2.34	0.17	0.00	-0.38	0.00	0.00	-0.02
	Hrazdan	0.22	1.92	0.47	-0.30	0.24	-0.30	0.00	0.00	-0.45	0.00	-0.05
	Metsamor	0.09	-0.35	-11.99	0.42	0.10	-0.18	0.00	0.00	-1.22	0.00	0.13
	Sevan	0.05	-0.66	-0.60	-2.11	-0.10	-0.03	0.01	0.02	0.00	0.00	-0.03
	Vorotan	1.04	1.60	-2.18	-1.30	3.65	-2.91	0.03	0.74	-0.07	0.00	-0.18
Armenia	1.93	-3.17	-36.72	-11.72	2.23	-3.51	0.05	-0.28	0.17	0.00	-1.23	
Changes in provided baseflow from 2023 to 2017, % relative to 2017	Aghstev	0.00	2.78	0.00	10.17	-0.48	0.92	0.00	-2.30	0.00	0.00	0.00
	Akhuryan	0.31	-5.43	-19.24	-9.55	0.00	2.24	0.00	0.00	-0.57	0.00	-27.86
	Arpa	0.00	0.04	0.00	0.16	1.76	-17.10	0.10	0.00	2.42	0.00	7.89
	Debed	2.51	-0.38	-7.36	-12.41	-5.03	1.56	0.00	-16.73	0.00	0.00	-1.26
	Hrazdan	0.53	4.21	1.14	-1.14	0.55	-10.86	0.00	0.00	-3.40	0.00	-4.65
	Metsamor	0.10	-1.02	-10.93	1.37	1.18	-11.49	0.00	0.00	-0.98	0.00	7.02
	Sevan	0.15	-0.91	-4.80	-6.86	-1.69	-4.27	0.48	20.45	0.00	0.00	-1.17
	Vorotan	1.04	2.43	-7.79	-2.56	8.99	-19.93	5.88	3.63	-0.36	0.00	-17.72
Armenia	0.46	-0.56	-9.34	-3.70	1.07	-8.12	0.52	-0.55	0.07	0.00	-6.54	

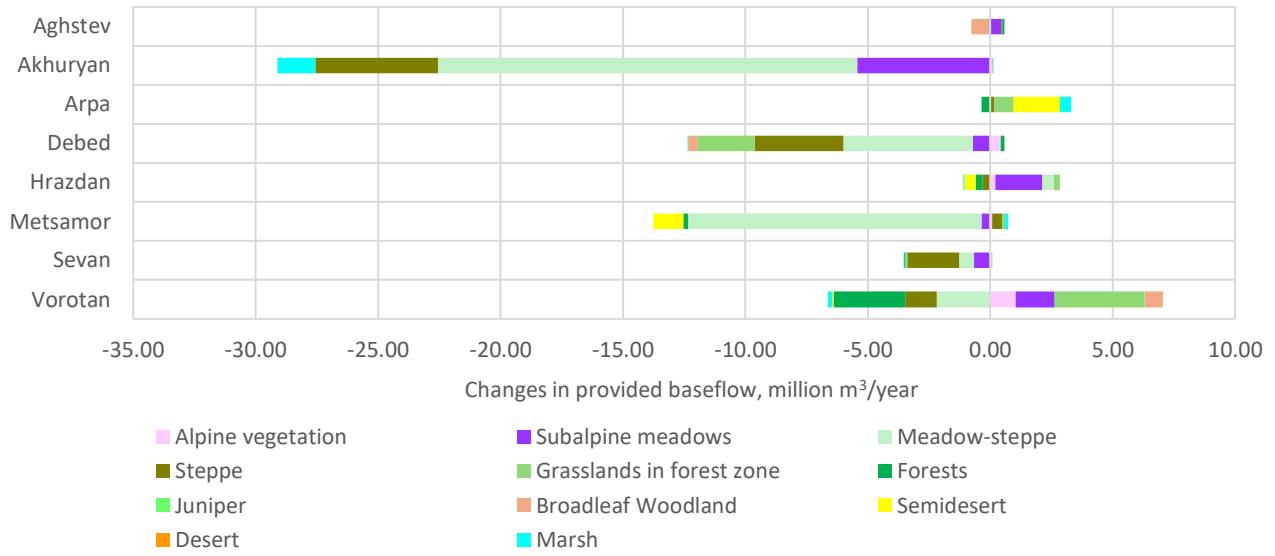
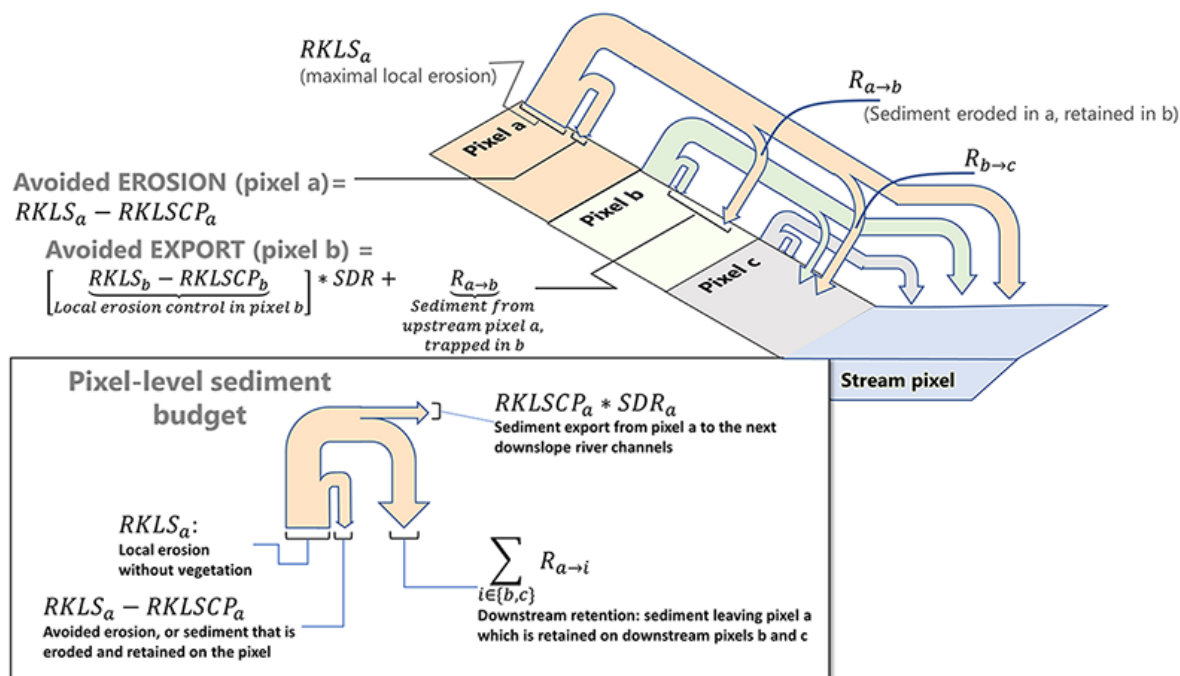

Figure 3.1.B3-4. Changes in provided baseflow from 2023 to 2017, millions of m³

375
376

377 **3.1.C. Prevention of soil water erosion and sediment transport to waterbodies (InVEST SDR)**

378 Two ES - 1) prevention of soil water erosion and 2) ensuring water flow quality due to prevention of sediment
 379 transport to waterbodies - were estimated and mapped using InVEST Sediment Delivery Ratio (SDR) model²⁵. The InVEST
 380 SDR model focuses only on overland erosion. Outputs from the model include the sediment load delivered to the stream
 381 at an annual time scale, as well as the amount of sediment eroded in the catchment and retained by vegetation and
 382 topographic features. The main indicator of the ES of prevention of soil erosion is avoided erosion, and the main indicator
 383 of the ES of ensuring water flow quality is avoided sediment export to streams (Figure 3.1.C1-1).



384
385 Figure 3.1.C1-1. Scheme of InVEST SDR model (InVEST User Guide (Natural Capital Project)).

386 **3.1.C1. Potential ES provided by terrestrial ecosystems**

387 In 2023, total avoided erosion was estimated to be 140.7 million tons per year, and total avoided sediment export to
 388 streams was estimated to be 12.1 million tons per year. ES maps show that current erosion and sediment export are
 389 negligible, whereas avoided erosion and sediment exports are many times higher (Figure 3.1.C1-2, note that the scale
 390 values for current sediment export are one-tenth of those for avoided export). On average, terrestrial ecosystems prevent
 391 about 95% of erosion and 96% of sediment export in Armenia (Table 3.1.C1-1).

392 The SDR model estimated that vegetation prevents more than 90% of erosion in all watersheds and provinces (except
 393 for the Armavir province with 89%) and more than 95% of sediment export everywhere. The highest rates of avoided
 394 erosion were calculated for watersheds Aghstev, Vorotan, and Debed and the corresponding provinces Tavush, Syunik,
 395 and Lori. The lowest values were found for watersheds Metsamor and Akhuryan and for the province Armavir. The highest
 396 rates of avoided sediment export were calculated for the same watersheds and provinces Syunik, Vayots Dzor, and Lori.
 397 The lowest values were found for watersheds Metsamor and Akhuryan and for the province Armavir (Figures 3.1.C1-3
 398 and 3.1.C1-4). This pattern, in general, is also evident for the total values of avoided erosion and sediment export (Tables
 399 3.1.C1-2 and 3.1.C1-3).

400 Table 3.1.C1-1. Potential ES indicators in Armenia (the calculations were carried out for the entire territory of Armenia)

Indicator	Land cover 2023	Bare ground scenario	ES Provided by ecosystems	Change in ES due to ecosystem functioning %
Erosion	2.3 t/ha/year 6.8 Mt/year	48.6 t/ha/year 147.2 Mt/year	Avoided erosion -46.4 t/ha/year -140.7 Mt/year	-95%
Sediment export	0.15 t/ha/year 0.47 Mt/year	4.5 t/ha/year 13.5 Mt/year	Avoided sediment export -4.3 t/ha/year -12.1 Mt/year	-96%

²⁵ <http://releases.naturalcapitalproject.org/invest-userguide/latest/en/sdr.html>

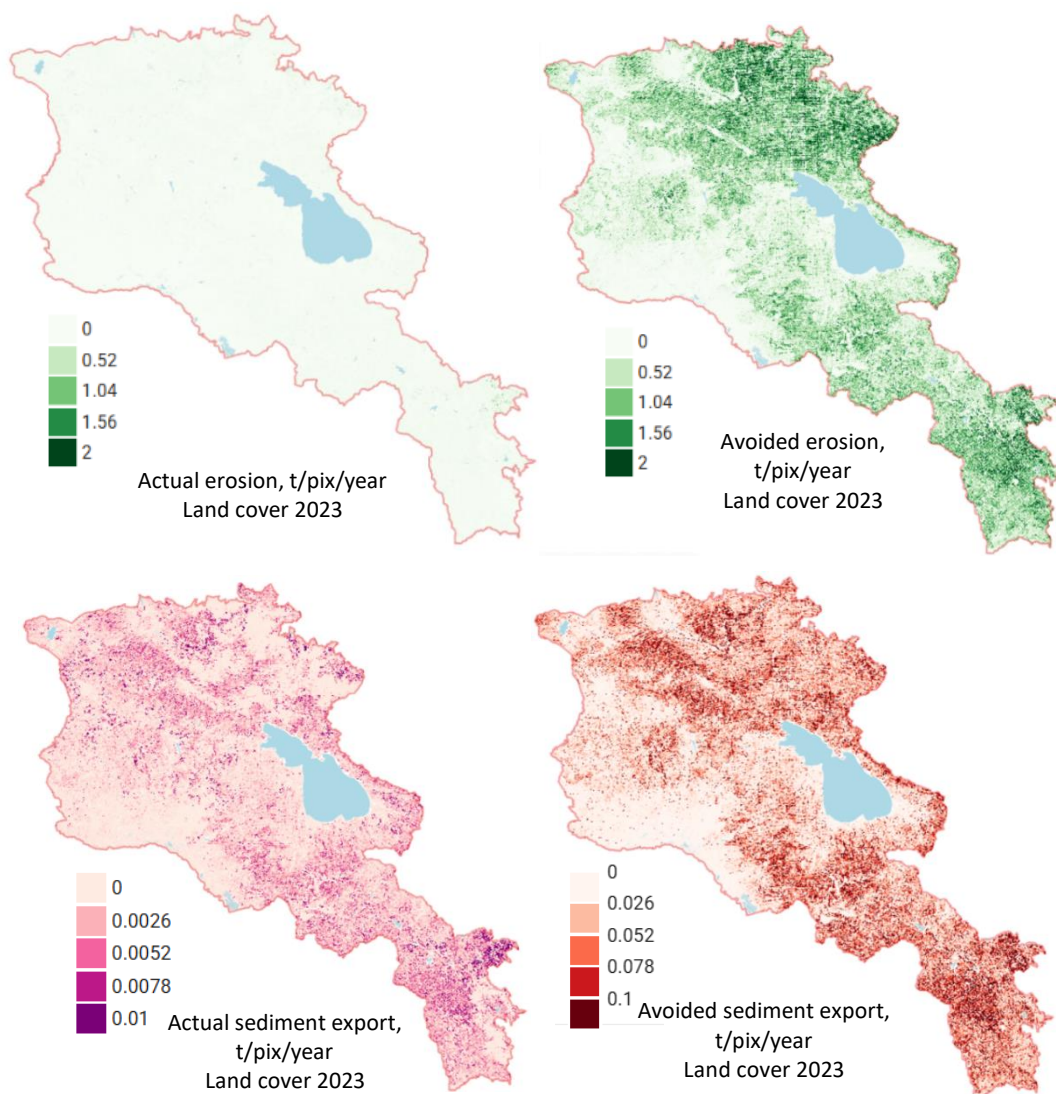

401

402
403
404
405
406
407
408

Figure 3.1.C1-2. Potential ES indicators with current land cover, 2023. For details see project Web GIS <https://bccarmenia.nextgis.com/>, section "Ecosystem services. Sediment Delivery Ratio"

Table 3.1.C1-2. Indicators of erosion across watersheds and marzes (the calculations were carried out for the entire territory of Armenia)

		Erosion under bare ground scenario, t/ha/year	Current erosion in 2023, t/ha/year	Avoided erosion, t/ha/year	Total erosion under bare ground scenario, Mt/year	Total current erosion, Mt/year	Total avoided erosion, Mt/year	Share of avoided erosion*, %
Water-sheds	Aghstev	96.0	2.5	93.5	29.7	0.8	28.9	97.4
	Akhuryan	24.7	2.0	23.0	6.6	0.5	6.1	92.0
	Arpa	49.6	2.5	47.0	21.1	1.1	20.1	95.0
	Debed	75.2	2.9	72.4	28.7	1.1	27.6	96.1
	Hrazdan	34.3	1.9	32.3	19.8	1.1	18.6	94.3
	Metsamor	20.3	1.3	19.0	7.1	0.5	6.6	93.6
	Vorotan	78.8	4.0	75.0	34.3	1.7	32.6	94.9
Marzes	Aragatsotn	26.8	1.6	25.2	7.1	0.4	6.6	93.9
	Ararat	33.8	1.7	32.1	6.9	0.3	6.5	94.9
	Armavir	3.9	0.4	3.5	0.5	0.1	0.4	89.1
	Gegharkunik	41.1	2.3	38.8	15.8	0.9	14.9	94.4
	Kotayk	37.7	2.0	35.7	7.7	0.4	7.3	94.6
	Lori	76.5	2.9	73.6	28.0	1.1	26.9	96.2
	Shirak	27.4	2.1	25.3	7.1	0.5	6.6	92.3
	Syunik	78.8	4.0	74.8	34.3	1.7	32.6	94.9
	Tavush	99.2	2.4	96.8	26.4	0.6	25.7	97.6
	Vayots Dzor	60.8	3.1	57.7	13.6	0.7	12.9	95.0

409 * Share from the sum of current and avoided sediment export

410
411

Table 3.1.C1-3. Indicators of sediment export across watersheds and marzes (the calculations were carried out for the entire territory of Armenia)

		Current sediment export in 2023, t/ha/year	Avoided sediment export, t/ha/year	Total current sediment export 2023, Mt/year	Total avoided sediment export 2023, Mt/year	Share of avoided sediment export, %*
Water-sheds	Aghstev	0.2	5.5	0.0	1.7	97.3
	Akhuryan	0.1	2.9	0.0	0.8	95.3
	Arpa	0.2	5.2	0.1	2.2	96.7
	Debed	0.2	5.9	0.1	2.2	96.7
	Hrazdan	0.1	3.5	0.1	2.0	96.4
	Metsamor	0.1	2.1	0.0	0.7	96.1
	Vorotan	0.3	7.8	0.1	3.4	96.2
Marzes	Aragatsotn	0.1	2.7	0.0	0.7	96.2
	Ararat	0.1	3.5	0.0	0.7	96.5
	Armavir	0.0	0.5	0.0	0.1	95.1
	Gegharkunik	0.1	4.2	0.1	1.6	96.6
	Kotayk	0.1	3.6	0.0	0.7	96.1
	Lori	0.2	5.9	0.1	2.1	97.0
	Shirak	0.1	3.2	0.0	0.8	96.2
	Syunik	0.3	7.8	0.1	3.4	96.6
	Tavush	0.2	5.4	0.0	1.4	97.2
	Vayots Dzor	0.2	6.4	0.0	1.4	96.6

412 * Share from the sum of current and avoided sediment export

413

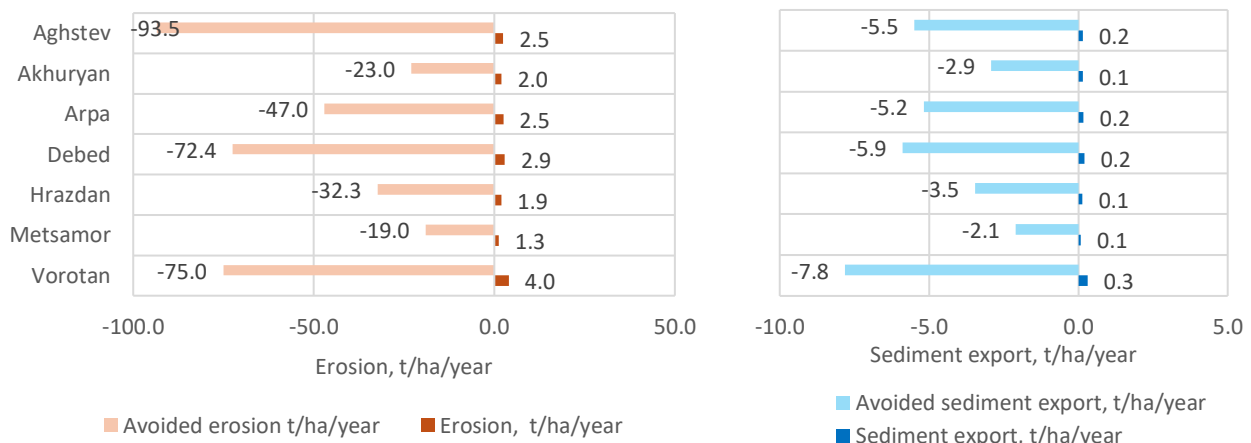

414

415

Figure 3.1.C1-3. Potential ES indicators across watersheds

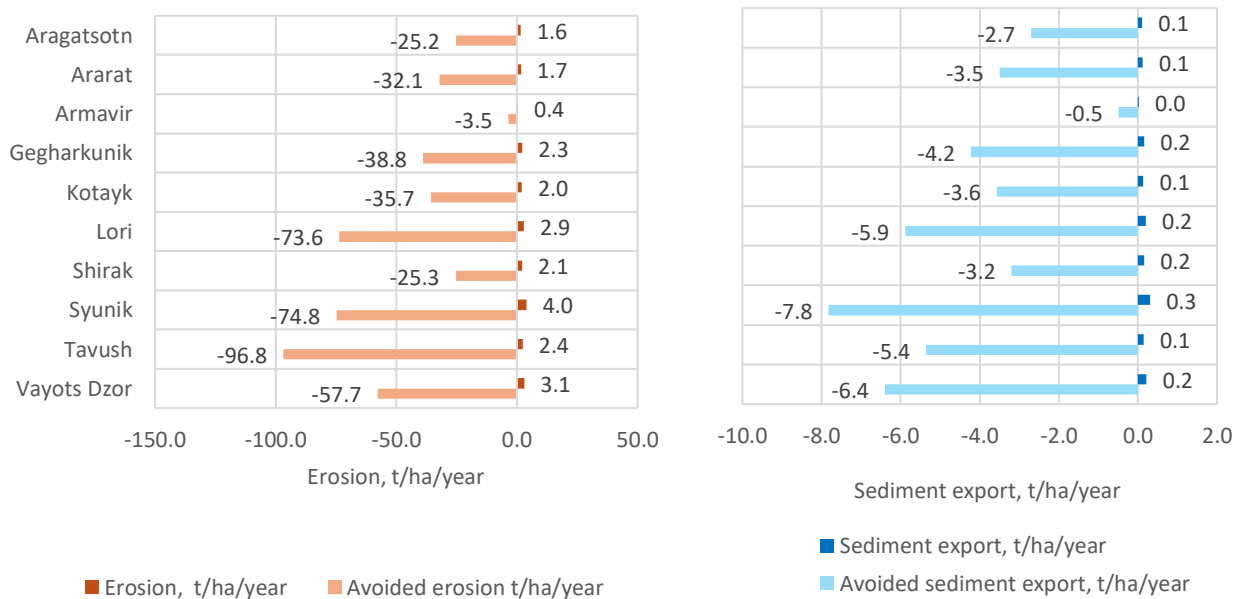

416

417

Figure 3.1.C1-4. Potential ES indicators across marzes

418 Further analysis was conducted only for natural areas, excluding croplands and built-up areas.

419 The highest rates of total avoided erosion and sediment export were calculated for marzes Syunik, and Lori. High total
 420 avoided-erosion values were also modeled for Tavush marz. The lowest values of avoided erosion and sediment export
 421 were found for Armavir (Table 3.1.C1-2; Figure 3.1.C1-3 b, d).

422 In Tavush marz, forests provide the largest share of erosion prevention (62%). In other marzes, erosion is prevented
 423 mainly by steppe and subalpine ecosystems, although forests also play a significant role in Lori and Syunik. In preventing
 424 sediment export to water bodies, the role of forests is substantially smaller. It contributes a substantial share of this ES
 425 only in Tavush marz (Table 31C1-2; Figure 31C1-3 a, c). Due to the reduced role of forests, this marz’s role in preventing
 426 sediment export also decreases compared to erosion prevention.

427 Among vegetation types, forests are the most effective in preventing erosion and provide the largest overall
 428 contribution to this ES in Armenia, despite their relatively small area (Figure 3.1.C1-4, a, b). All types of woodlands and
 429 grasslands, except for semi-desert and desert, are also highly effective in erosion prevention (Figure 3.1.C1-4, a). The
 430 total avoided erosion values are high for subalpine meadows, steppes, and grasslands within the forest zone (Figure
 431 3.1.C1-4, b). The pattern for avoided sediment export generally mirrors that of avoided erosion, except for the
 432 substantially reduced role of forests (Figure 3.1.C1-4 c, d).

433

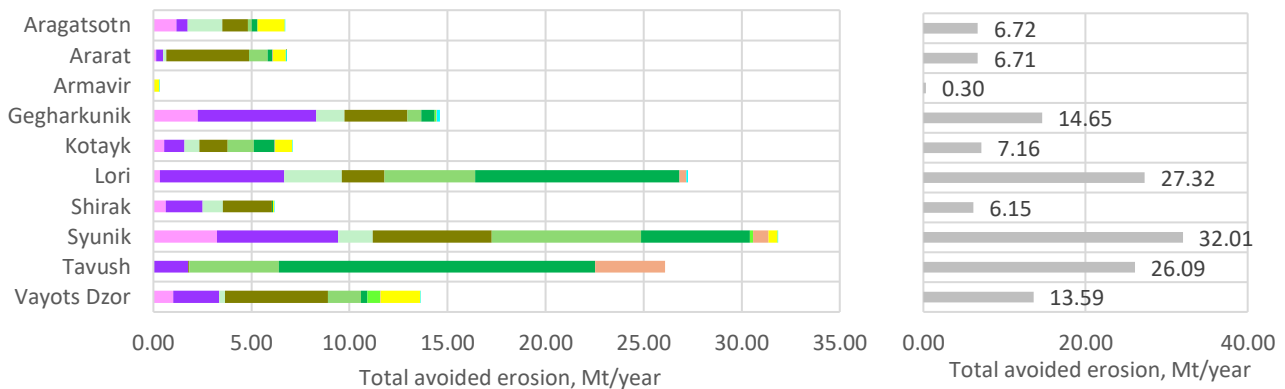

434

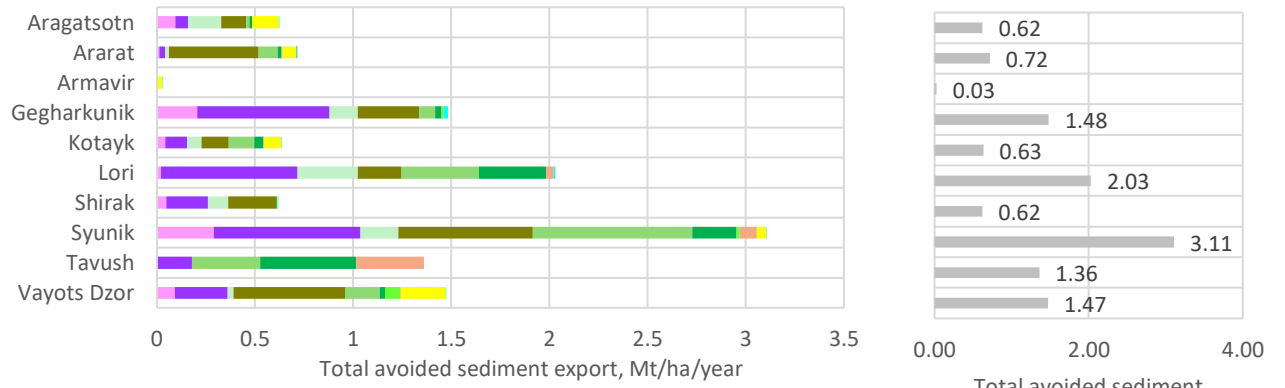

435



436 Figure 3.1.C1-3. Total avoided erosion (a, b) and sediment export (c, d) across marzes. The charts on the left (a, c) show
 437 values broken down by vegetation types, the charts on the right (b, d) show aggregate totals by marzes.

438

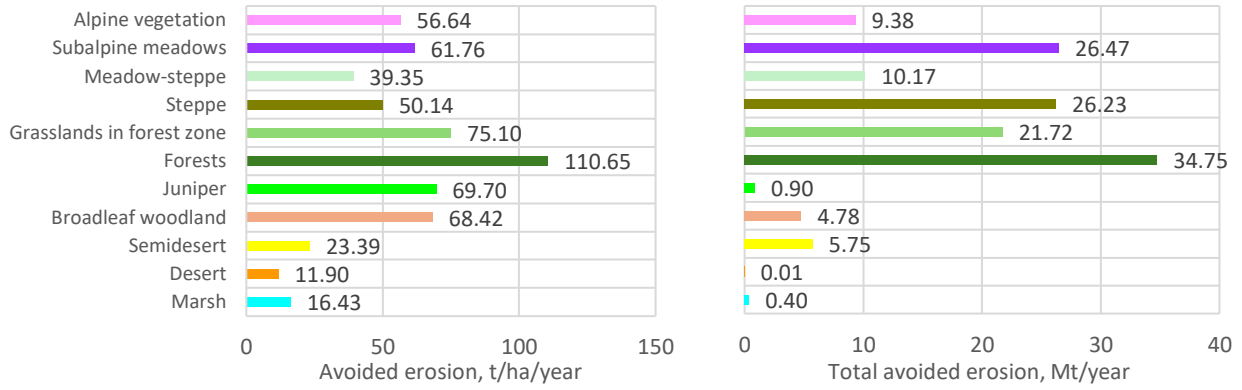

439

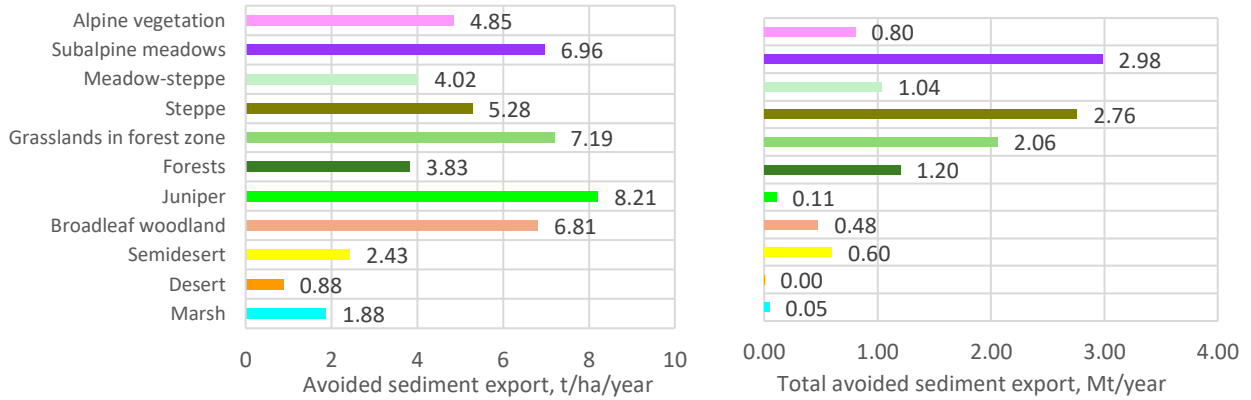

440

Figure 3.1.C1-4. ES indicators across vegetation types

441

Table 31C1-2. Avoided erosion and avoided sediment export across vegetation types and marzes in 2023

		Alpine vegetation	Subalpine meadows	Meadow-steppe	Steppe	Grassl. in forest zone	Forests	Juniper	Broadleaf woodland	Semidesert	Desert	Marsh	Average
Avoided Erosion T/ha	Aragatsotn	57.94	51.91	35.29	25.07	46.38	59.27	0.00	0.00	18.80	0.00	22.66	30.90
	Ararat	38.72	55.87	49.59	57.64	54.50	88.79	0.00	32.03	14.78	11.90	9.23	42.54
	Armavir	0.00	0.00	0.00	0.00	0.00	5.21	0.00	0.00	6.77	0.00	1.80	6.69
	Gegharkunik	58.30	47.04	35.99	39.40	31.41	52.91	39.77	10.99	0.00	0.00	19.53	43.49
	Kotayk	47.17	59.63	34.25	31.76	49.26	69.04	0.00	38.14	31.55	0.00	36.47	42.61
	Lori	75.77	74.73	45.10	64.91	87.87	115.76	0.00	83.98	0.00	0.00	28.25	80.86
	Shirak	49.50	46.21	25.47	30.17	0.00	52.42	0.00	0.00	19.12	0.00	5.20	33.60
	Syunik	61.99	75.87	60.46	77.63	87.46	113.87	118.30	55.54	41.12	0.00	39.87	79.16
	Tavush	71.59	84.26	0.00	86.04	85.58	120.09	0.00	73.59	0.00	0.00	0.00	101.17
	Vayots Dzor	48.06	60.87	38.33	68.83	68.55	82.97	69.27	33.03	55.30	0.00	30.54	62.13
Average		56.64	61.76	39.35	50.14	75.10	110.65	69.70	68.42	23.39	11.90	16.43	
Total avoided Erosion Mt/year		Alpine vegetation	Subalpine meadows	Meadow-steppe	Steppe	Grassl. in forest zone	Forests	Juniper	Broadleaf woodland	Semidesert	Desert	Marsh	Total
	Aragatsotn	1.18	0.56	1.77	1.30	0.20	0.29	0.00	0.00	1.40	0.00	0.01	6.72
	Ararat	0.14	0.35	0.15	4.23	0.96	0.23	0.00	0.03	0.66	0.01	0.05	6.71
	Armavir	0.00	0.00	0.00	0.00	0.00	0.00	0.00	0.00	0.30	0.00	0.00	0.30
	Gegharkunik	2.27	6.02	1.44	3.22	0.71	0.68	0.08	0.01	0.00	0.00	0.18	14.65
	Kotayk	0.54	1.05	0.76	1.43	1.34	1.07	0.00	0.01	0.88	0.00	0.03	7.16
	Lori	0.34	6.34	2.93	2.19	4.63	10.41	0.00	0.35	0.00	0.00	0.09	27.32
	Shirak	0.64	1.87	1.05	2.49	0.00	0.07	0.00	0.00	0.03	0.00	0.02	6.15
	Syunik	3.25	6.17	1.76	6.07	7.62	5.55	0.15	0.81	0.45	0.00	0.03	32.01
	Tavush	0.00	1.78	0.00	0.06	4.57	16.14	0.00	3.56	0.00	0.00	0.00	26.09
Vayots Dzor	1.01	2.34	0.30	5.25	1.69	0.31	0.67	0.02	2.02	0.00	0.00	13.59	
Total		9.38	26.47	10.17	26.23	21.72	34.75	0.90	4.78	5.75	0.01	0.40	140.70

		Alpine vegetation	Subalpine meadows	Meadow-steppe	Steppe	Grassl. in forest zone	Forests	Juniper	Broadleaf woodland	Semidesert	Desert	Marsh	Average
Avoided sediment export, T/ha	Aragatsotn	4.55	6.20	3.37	2.46	4.02	2.72	0.00	0.00	1.82	0.00	2.43	2.88
	Ararat	3.30	4.95	5.60	6.22	5.67	7.30	0.00	3.44	1.60	0.88	0.95	4.50
	Armavir	0.00	0.00	0.00	0.00	0.00	0.72	0.00	0.00	0.56	0.00	0.37	0.56
	Gegharkunik	5.27	5.26	3.57	3.83	3.56	2.64	4.95	1.57	0.00	0.00	2.26	4.43
	Kotayk	3.70	6.37	3.26	3.08	4.80	3.04	0.00	4.26	3.12	0.00	3.53	3.78
	Lori	4.60	8.19	4.75	6.57	7.52	3.80	0.00	8.63	0.00	0.00	2.74	6.01
	Shirak	3.66	5.24	2.52	2.99	0.00	2.73	0.00	0.00	1.56	0.00	1.21	3.39
	Syunik	5.54	9.19	6.64	8.74	9.32	4.63	13.28	5.97	4.44	0.00	5.01	7.71
	Tavush	4.29	8.39	0.00	7.52	6.47	3.63	0.00	7.14	0.00	0.00	0.00	5.28
	Vayots Dzor	4.35	6.95	3.93	7.45	7.15	7.35	8.21	4.56	6.22	0.00	3.35	6.72
Average	4.85	6.96	4.02	5.28	7.19	3.83	8.21	6.81	2.43	0.88	1.88		
		Alpine vegetation	Subalpine meadows	Meadow-steppe	Steppe	Grassl. in forest zone	Forests	Juniper	Broadleaf woodland	Semidesert	Desert	Marsh	Total
Total avoided sediment export, Mt/year	Aragatsotn	0.093	0.066	0.169	0.127	0.017	0.013	0.000	0.000	0.136	0.000	0.001	0.623
	Ararat	0.012	0.031	0.017	0.456	0.100	0.019	0.000	0.003	0.071	0.001	0.005	0.716
	Armavir	0.000	0.000	0.000	0.000	0.000	0.000	0.000	0.000	0.025	0.000	0.000	0.026
	Gegharkunik	0.206	0.674	0.143	0.314	0.081	0.034	0.010	0.002	0.000	0.000	0.021	1.483
	Kotayk	0.042	0.112	0.072	0.139	0.131	0.047	0.000	0.001	0.087	0.000	0.003	0.634
	Lori	0.021	0.695	0.309	0.222	0.396	0.342	0.000	0.036	0.000	0.000	0.009	2.028
	Shirak	0.047	0.212	0.104	0.246	0.000	0.004	0.000	0.000	0.003	0.000	0.003	0.619
	Syunik	0.290	0.747	0.193	0.683	0.813	0.226	0.017	0.087	0.049	0.000	0.003	3.108
	Tavush	0.000	0.177	0.000	0.005	0.345	0.487	0.000	0.345	0.000	0.000	0.000	1.360
	Vayots Dzor	0.092	0.268	0.031	0.569	0.176	0.028	0.079	0.002	0.227	0.000	0.000	1.471
	Total	0.803	2.981	1.038	2.760	2.059	1.200	0.106	0.476	0.598	0.001	0.046	12.068

442

443

3.1.C2. Changes in ES potential from 2017 to 2023

444

We assessed only changes in ES potential, since we have no data on ES use for 2017.

445

Assessment of ES changes based on the 2017 and 2023 modelled ES maps

446

Changes in the landcover from 2017 to 2023 (Section 2.2.B) resulted in changes in avoided erosion and sediment export. The maps show that the changes are sporadic and oppositely directed (Figure 31C2-1). These changes represent only tenths of a percent of total ES volume but can be important for tracking trends.

448

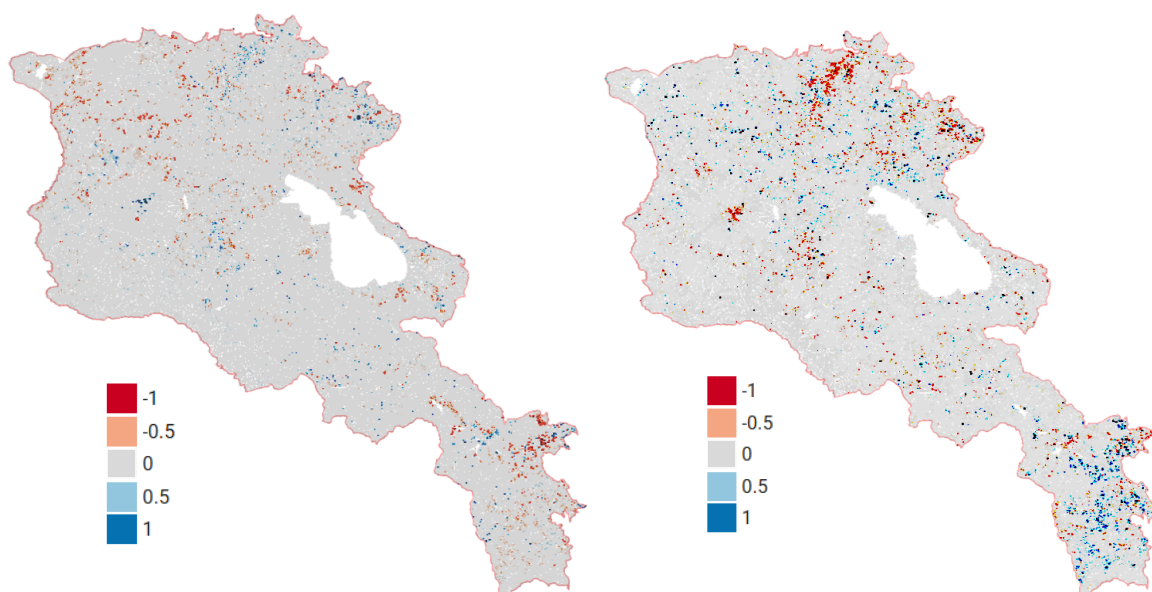

449

450

Figure 3.1.C2-1. Potential ES changes from 2017 to 2023: a) Changes in avoided erosion; b) Changes in avoided sediment export. For details see project Web GIS <https://bccarmenia.nextgis.com/>, section "Ecosystem services. Sediment Delivery Ratio"

452

453 The difference between the modeled potential ES values in 2023 (Table 3.1.C1-2) and 2017 (Appendix 3.1.C-1) gives
 454 the change in ES over this period (Table 3.1.C2-1). Aggregate changes in ES capacity indicators relative to 2017 are small—
 455 0.1–5% for marzes and 0.6–7% for vegetation types. In absolute terms, the most noticeable changes occurred in the
 456 marzes of Syunik and Lori. In Syunik, the ES capacity of forests decreased while the capacity of grasslands within the
 457 forest zone increased, apparently due to the replacement of some forests by grasslands (Section 2.3). In Lori, the opposite
 458 pattern is observed: ES capacity increased for forests and decreased for forest grasslands and steppes (Figure 3.1.C2-2,
 459 a, b). However, these opposing changes largely offset one another within the marzes (Figure 3.1.C2-2, c, d).
 460

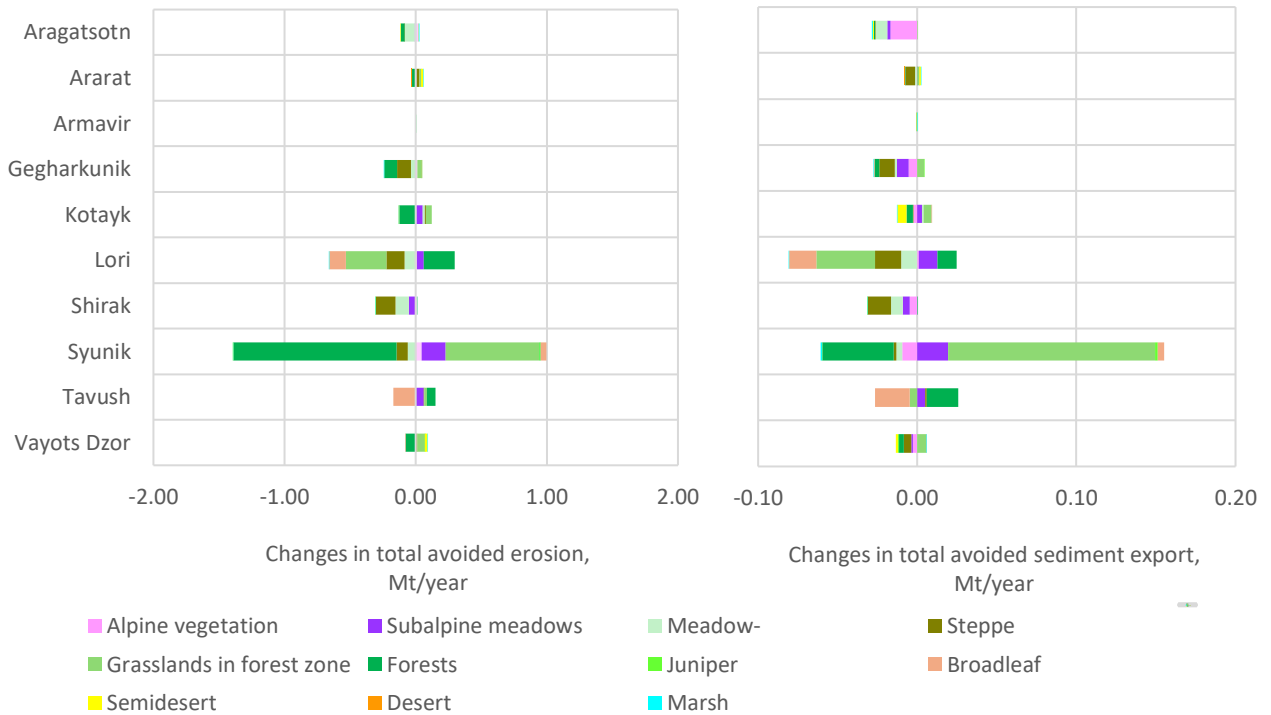

461

462

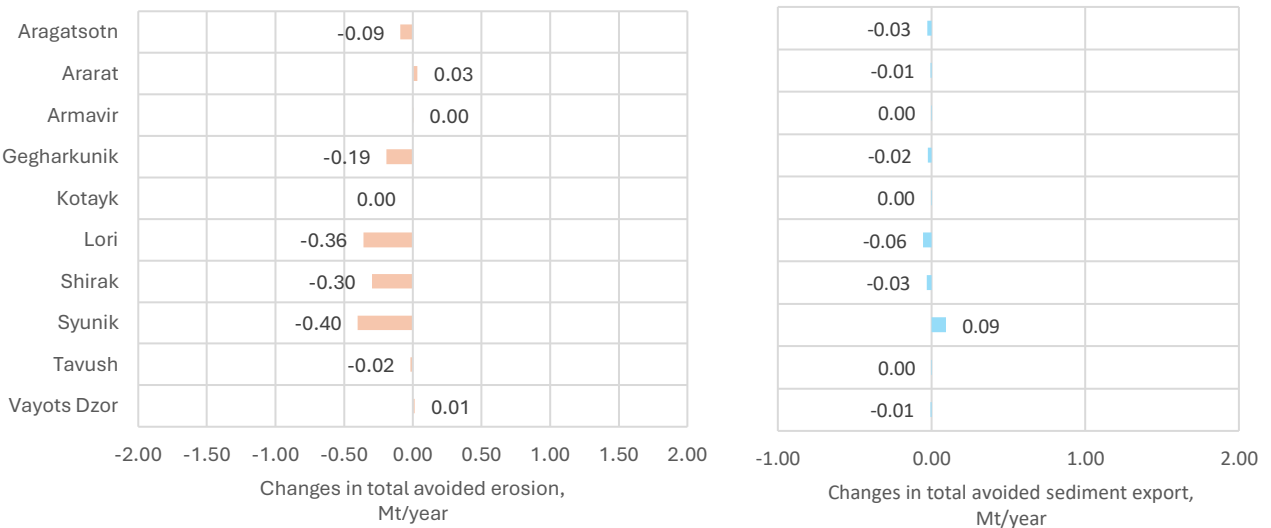

463

464

Figure 3.1.C2-2. Changes in avoided erosion and avoided sediment export across vegetation types and marzes.

465

466

Table 3.1.C2-1. Changes in avoided erosion and avoided sediment export across vegetation types and marzes

		Alpine vegetation	Subalpine meadows	Meadow-steppe	Steppe	Grassl. in forest zone	Forests	Juniper	Broadleaf woodland	Semidesert	Desert	Marsh	Total
Avoided erosion Mt/year	Aragatsotn	0.02	-0.01	-0.08	0.00	0.00	-0.03	0.00	0.00	0.00	0.00	0.00	-0.09
	Ararat	0.00	0.00	0.00	0.02	0.01	-0.03	0.00	0.00	0.02	0.00	0.00	-0.07
	Armavir	0.00	0.00	0.00	0.00	0.00	0.00	0.00	0.00	0.00	0.00	0.00	0.00
	Gegharkunik	0.01	0.00	-0.04	-0.11	0.03	-0.09	0.00	0.00	0.00	0.00	0.00	-0.17
	Kotayk	0.01	0.05	0.02	0.01	0.04	-0.12	0.00	0.00	0.00	0.00	0.00	0.04
	Lori	0.01	0.05	-0.09	-0.14	-0.31	0.24	0.00	-0.13	0.00	0.00	0.00	-0.31
	Shirak	0.01	-0.05	-0.10	-0.15	0.00	0.00	0.00	0.00	0.00	0.00	-0.01	-0.31
	Syunik	0.05	0.18	-0.06	-0.08	0.72	-1.25	0.01	0.05	0.00	0.00	0.00	-0.24
	Tavush	0.00	0.06	0.00	0.01	0.02	0.07	0.00	-0.17	0.00	0.00	0.00	-0.02
	Vayots Dzor	0.00	0.00	0.00	0.01	0.06	-0.08	0.00	0.00	0.02	0.00	0.00	-0.01
Total	0.11	0.28	-0.34	-0.43	0.58	-1.29	0.01	-0.25	0.03	0.00	-0.01	-1.18	
Avoided sediment export, Mt/year	Aragatsotn	-0.02	0.00	-0.01	0.00	0.00	0.00	0.00	0.00	0.00	0.00	0.00	-0.03
	Ararat	0.00	0.00	0.00	-0.01	0.00	0.00	0.00	0.00	0.00	0.00	0.00	-0.01
	Armavir	0.00	0.00	0.00	0.00	0.00	0.00	0.00	0.00	0.00	0.00	0.00	0.00
	Gegharkunik	-0.01	-0.01	0.00	-0.01	0.00	0.00	0.00	0.00	0.00	0.00	0.00	-0.02
	Kotayk	0.00	0.00	0.00	0.00	0.01	0.00	0.00	0.00	-0.01	0.00	0.00	0.00
	Lori	0.00	0.01	-0.01	-0.02	-0.04	0.01	0.00	-0.02	0.00	0.00	0.00	-0.06
	Shirak	0.00	0.00	-0.01	-0.01	0.00	0.00	0.00	0.00	0.00	0.00	0.00	-0.03
	Syunik	-0.01	0.02	0.00	0.00	0.13	-0.04	0.00	0.00	0.00	0.00	0.00	0.09
	Tavush	0.00	0.01	0.00	0.00	0.00	0.02	0.00	-0.02	0.00	0.00	0.00	0.00
	Vayots Dzor	0.00	0.00	0.00	0.00	0.01	0.00	0.00	0.00	0.00	0.00	0.00	-0.01
Total	-0.04	0.02	-0.03	-0.05	0.11	-0.02	0.00	-0.04	-0.01	0.00	0.00	-0.06	
Total avoided erosion, % relative to 2017	Aragatsotn	1.69	-1.17	-4.18	-0.06	2.18	-9.14	0.00	0.00	-0.12	0.00	6.67	-1.33
	Ararat	0.33	0.97	0.69	0.55	1.22	-10.83	0.00	0.07	3.03	-1.00	3.87	0.48
	Armavir	0.00	0.00	0.00	0.00	0.00	-70.89	0.00	0.00	0.13	0.00	46.00	0.09
	Gegharkunik	0.53	-0.03	-2.39	-3.19	4.86	-12.25	0.32	9.77	0.00	0.00	-0.74	-1.30
	Kotayk	1.22	4.51	2.15	0.75	3.37	-10.36	0.00	-0.16	-0.16	0.00	-0.35	-0.04
	Lori	3.10	0.81	-2.83	-5.96	-6.23	2.33	0.00	-26.40	0.00	0.00	-2.34	-1.31
	Shirak	1.34	-2.74	-8.78	-5.66	0.00	3.77	0.00	0.00	-0.34	0.00	-26.22	-4.61
	Syunik	1.47	2.99	-3.27	-1.37	10.36	-18.35	5.64	6.00	-0.11	0.00	-14.99	-1.24
	Tavush	-0.65	3.53	0.00	12.44	0.39	0.42	0.00	-4.52	0.00	0.00	0.00	-0.06
	Vayots Dzor	0.12	0.07	0.05	0.16	3.60	-19.70	0.18	-0.30	0.88	0.00	16.24	0.09
Total	1.14	1.07	-3.25	-1.62	2.73	-3.59	1.06	-4.92	0.59	-1.00	-2.50	-0.93	
Total avoided sediment export, % relative to 2017	Aragatsotn	-15.25	-2.89	-4.31	-0.12	2.16	-5.58	0.00	0.00	-0.31	0.00	-39.62	-4.33
	Ararat	-2.70	0.24	-5.71	-1.28	1.37	-3.11	0.00	0.19	1.34	-1.65	1.96	-0.76
	Armavir	0.00	0.00	0.00	0.00	0.00	-87.93	0.00	0.00	-1.21	0.00	9.66	-1.90
	Gegharkunik	-2.50	-1.12	-0.93	-2.95	5.78	-8.43	0.06	-11.70	0.00	0.00	-0.62	-1.52
	Kotayk	-5.24	2.81	1.10	-0.28	4.03	-7.69	0.00	1.37	-6.36	0.00	-1.73	-0.58
	Lori	4.07	1.76	-3.21	-6.80	-8.56	3.57	0.00	-32.26	0.00	0.00	-3.55	-2.70
	Shirak	-9.10	-1.97	-6.61	-5.68	0.00	8.25	0.00	0.00	-2.26	0.00	-7.34	-4.80
	Syunik	-3.19	2.66	-1.78	-0.24	19.06	-16.58	10.16	5.11	-0.55	0.00	-23.99	3.13
	Tavush	-1.31	2.91	0.00	20.16	-1.35	4.23	0.00	-5.97	0.00	0.00	0.00	-0.08
	Vayots Dzor	-2.74	-0.45	0.06	-0.82	3.29	-9.51	-0.67	0.74	-0.58	0.00	22.60	-0.52
Total	-4.83	0.82	-2.84	-1.87	5.38	-2.01	0.97	-6.86	-1.21	-1.65	-5.14	-0.52	

467

468

469

470

471

472

473

474

In terms of vegetation types across Armenia as a whole, the most noticeable trend is the increase in ES capacity of grasslands within the forest zone and the decrease in the capacity of forests, steppes, and meadow-steppe, which corresponds to changes in their area (Section 2.3). Changes in forest area (decrease in that case) affect the ES of erosion prevention more strongly than changes in other vegetation types, since forests are the most effective in this ES (Figure 3.1.C1-4a). The ES of sediment export prevention is most affected by the increase in forest-zone grasslands, as these ecosystems are effective in this ES (Figure 3.1.C2-3). Alpine and subalpine grasslands, as well as woodlands, are also effective, but their contribution to overall changes is minor due to their small area or small changes in it (Section 2.3).

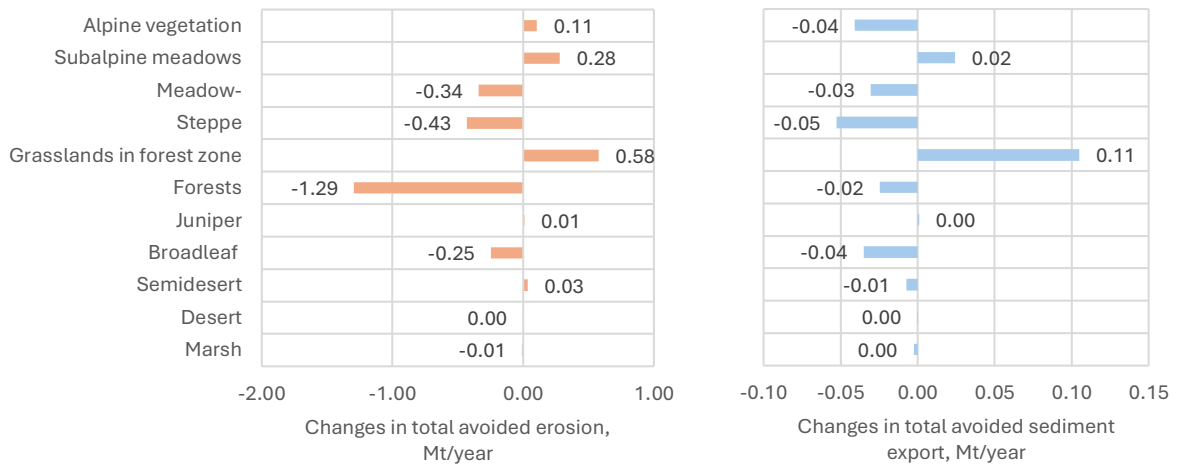

475
476

Figure 3.1.C2-3. Changes in avoided erosion and avoided sediment export across vegetation types in the whole Armenia.

477 When assessing the contribution of different vegetation/ecosystem types to ES performance, it should be kept in
 478 mind that ES capacity is determined not only by ecosystem type, but also by many other factors—such as slope, soil type,
 479 precipitation, proximity to watercourses, and others. Therefore, the functions of areas belonging to the same ecosystem
 480 type may vary significantly, as may the results of changes in ecosystem area.

481 Per-hectare ES provision by different vegetation types, averaged across Armenia, changed from 2017 to 2023 (Figure
 482 3.1.C2-4). The range of such changes within marzes is even larger (Appendix 3.1.C-2). These changes are not due to
 483 modifications of the ecosystems themselves, which we did not model, but to shifts in the mean conditions across their
 484 extent. For example, slope within the distribution of natural ecosystems in the woodland zone decreased while their total
 485 area increased, likely because gentler sites were taken out of agriculture. Conversely, slope within the distribution of
 486 various steppe types increased as their total area declined, likely because their gentler sites were ploughed. Thus, these
 487 changes affected the ES performance of vegetation types, since slope strongly influences the water-regulating and soil-
 488 conservation functions of ecosystems.

489

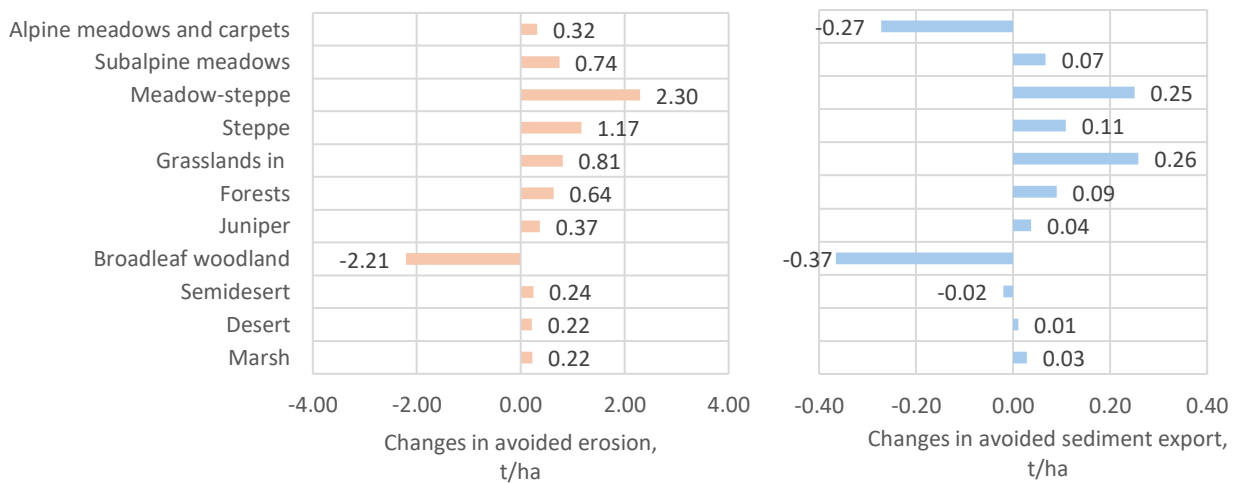

490

491 Figure 3.1.C2-4. Changes in per-hectare ES provision by different vegetation types, averaged across Armenia.

492

Assessment of ES changes based on the changes in area of vegetation types

493 Changes in potential ES can be assessed using the indicators of ES provisioning per ha across different vegetation
 494 types in 2023 (Table 3.1.C1-2) and 2017 (Appendix 6), together with their area and its changes between 2017 and 2023
 495 (Table 2.3.C-2). This approach makes it possible to calculate the data for the table recording the dynamics of the ES
 496 potential/capacity (Table 3.1.C2-2). For converting ES indicators into aggregate totals (Mt/yr), different per-hectare ES
 497 values were used for 2017 and 2023. Therefore, the totals in the accounting table do not coincide, because the changes
 498 are driven not only by shifts in the area of vegetation types but also by changes in the mean conditions across their
 499 distributions (see above sub-section).

500 With respect to changes in ES potential/capacity, the same comment applies as for changes in ecosystem extent
 501 (Section 2.3.A). Additions to ecosystem area resulting from transitions out of croplands or built-up areas do not possess
 502 full ecosystem functionality. Therefore, the closing ES capacity is defined more by the extent of ecosystems that remained
 503 untransformed during the reporting period than by the total closing ecosystem area.

504 Table 3.1.C2-2. Accounting table for the ES potential/capacity changes

		Value of per-ha ES provisioning used	Alpine vegetation	Subalpine meadows	Meadow-steppe	Steppe	Grassl. in forest zone	Forests	Juniper	Broadleaf woodland	Semi-desert	Desert	Marsh	Total	
Avoided erosion, Mt/year	Opening ES capacity in 2017	2017	9.27	26.24	10.53	26.66	21.18	36.08	0.89	5.02	5.74	0.01	0.38	142.00	
	Additions to ES capacity	2023	0.03	0.47	0.14	0.97	2.02	2.55	0.02	0.39	0.45	0.00	0.03	7.07	
	Managed/unmanaged	NA													
	Reductions ES capacity	2017	0.02	0.51	1.07	1.98	1.65	4.07	0.01	0.50	0.47	0.00	0.04	10.31	
	Managed/unmanaged	NA													
	Net change ES capacity	2023	0.01	-0.04	-1.00	-1.06	0.35	-1.54	0.01	-0.09	-0.03	0.00	-0.01	-3.40	
	Closing ES capacity in 2023	2023	9.33	26.52	10.18	26.24	21.76	34.75	0.90	4.77	5.77	0.01	0.38	140.61	
	Additional row – see discussion below														
Closing ES capacity in 2023 of ecosystems unconverted since 2017,	2023	9.30	26.04	10.04	25.27	19.74	32.20	0.89	4.38	5.32	0.01	0.35	133.54		
Avoided sediment export, Mt/year	Opening ES capacity in 2017	2017	0.844	2.966	1.072	2.817	1.977	1.227	0.105	0.510	0.608	0.001	0.044	0.844	
	Additions to ES capacity	2023	0.002	0.054	0.014	0.102	0.193	0.088	0.002	0.039	0.047	0.000	0.003	0.002	
	Managed/unmanaged	NA													
	Reductions ES capacity	2017	0.002	0.058	0.109	0.209	0.154	0.138	0.001	0.050	0.050	0.000	0.004	0.002	
	Managed/unmanaged	NA													
	Net change ES capacity	2023	0.001	-0.005	-0.102	-0.111	0.034	-0.053	0.001	-0.009	-0.003	0.000	-0.001	0.001	
	Closing ES capacity in 2023	2023	0.800	2.990	1.041	2.765	2.084	1.203	0.107	0.475	0.600	0.001	0.043	0.800	
	Additional row – see discussion below														
Closing ES capacity in 2023 of ecosystems unconverted since 2017,	2023	0.797	2.937	1.027	2.663	1.891	1.114	0.105	0.436	0.553	0.001	0.040	0.797		

505

506

3.1.C3. ES potential – supply/use balance

507 The indicators of total current and avoided sediment export in streams (Table 3.1.C1-2) allow us to determine the
 508 current and avoided sediment concentrations in river flow by dividing the aggregate totals by the river flow volume.
 509 Sediment concentrations in river flow due to current sediment export are from 22 to 126 grams of sediments per m3 of
 510 river flow (Table 3.1.C3-1). At the same time, current sediment concentrations in water amount to only 2–4% of those
 511 under the bare-soil scenario, where the effect of terrestrial ecosystems is absent (Table 3.1.C3-1).

512 We did not find suspended-sediment MPC indicators for Armenia’s rivers for water use that would allow the used ES
 513 to be determined accurately. Therefore, we proceeded from the temporary assumption that wherever river and stream
 514 water is used, the avoided-sediment-export ES is fully utilized.

515 The ES flow (supply=use) F_{ij} in watershed i for water use category j was calculated as the amount of avoided sediment
 516 within the consumed volume of water $F_{ij}=U_{ij}*C^{eco}_i$, where U_{ij} – water use in watershed i in category j ; C^{eco}_i – ecosystem
 517 effect on sediment concentrations in river flow due to a voided sediment export in watershed i (Table 3.1.C3-2). The ES
 518 flow (supply=use) is greatest in the watersheds with the highest water consumption—Metsamor and Hrazdan—and
 519 lowest in the Arpa and Debed watersheds (Fig. 3.1.C3-1).

520

521

522

523

524

525

526

527

528

529 Table 3.1.C3-1. Data to estimate ES use

	Water use*, millions of m ³				River flow*, millions of m ³	Ecosystem effect on sediment concentrations in river flow due to a voided sediment export, g/m ³ C^{eco}_i	Sediment concentrations in river flow due to current sediment export, g/m ³	The share of current sediment export in those on bare ground, %
	Drinking water	Industrial, domestic and construction	Agriculture, fish breeding, forestry	Total				
Aghstev	8.3	1.4	9.5	19.2	260.00	-5230.8	126.3	2.4
Akhuryan	7.9	2	95.7	105.6	700.70	-883.4	38.7	4.2
Arpa	2.2	0.8	14.2	17.2	1177.00	-1857.3	65.0	3.4
Debed	9.5	4.2	5.1	18.8	960.00	-2112.5	66.1	3.0
Hrazdan	56.7	41	340.5	438.2	788	-804.6	28.0	3.4
Metsamor	22.6	21.1	732.8	776.5	1043.30	-622.1	22.5	3.5
Sevan	12.1	1	46.2	59.3	615.66	-2408.8	83.4	3.3
Vorotan	7.4	63	19.1	89.5	1319.60	-2355.3	90.4	3.7
Armenia	132.5	139.7	2 150.1	2 422.3	6864.26	-1758.1	60.6	3.3

* For data sources see Section 3.1.B1

530
531 Table 3.1.C3-2. Supply-use table for ES of prevention of sediment export to streams. Sediment amount in water use,
532 prevented by ecosystems, Mt

Watershed		Drinking	Industrial, domestic and construction	Agriculture, fish breeding and forestry	Total	Total ES supply by all ecosystems
Aghstev	ES supply					0.100
	ES use	0.043	0.007	0.050	0.100	
Akhuryan	ES supply					0.093
	ES use	0.007	0.002	0.085	0.093	
Arpa	ES supply					0.032
	ES use	0.004	0.001	0.026	0.032	
Debed	ES supply					0.040
	ES use	0.020	0.009	0.011	0.040	
Hrazdan	ES supply					0.353
	ES use	0.046	0.033	0.274	0.353	
Metsamor	ES supply					0.483
	ES use	0.014	0.013	0.456	0.483	
Sevan	ES supply					0.143
	ES use	0.029	0.002	0.111	0.143	
Vorotan	ES supply					0.211
	ES use	0.017	0.148	0.045	0.211	
Armenia	ES supply					1.455
	ES use	0.181	0.216	1.057	1.455	

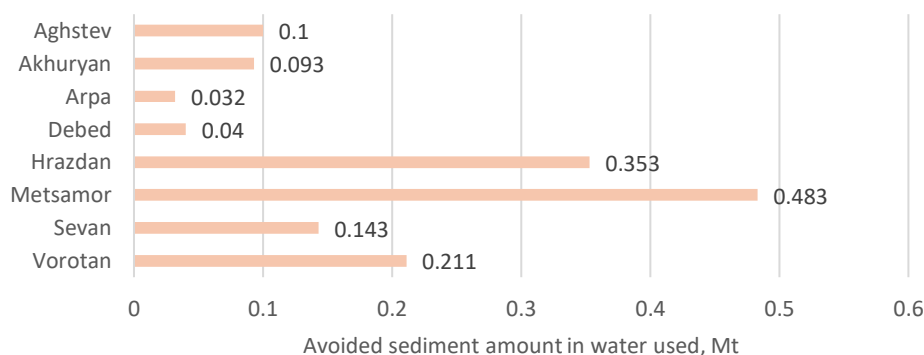

533
534 Figure 3.1.C3-1. ES flow: avoided total amount of sediment in the volume of water consumed

535 We cannot assess the contribution of vegetation types to the volume of prevented sediment export into the water
536 used, because we do not know the runoff volume from areas occupied by different vegetation types.

537 This assessment was made under the assumption that all water is abstracted from surface sources. In the future, it
538 will be necessary to account for the share of water consumption derived from artesian and groundwater.

539
540
541
542
543
544
545
546
547

3.1.D. Flood risk mitigation (InVEST Urban Flood Risk Mitigation)

The ES was estimated and mapped using InVEST Urban Flood Risk Mitigation model²⁶. We tested the model for two scenarios—average and extreme spring rainfall. The highest precipitation in Armenia occurs in May and June. While precipitation levels vary significantly across different climatic zones, for the initial model testing, we considered it reasonable to use countrywide average values. During these months, an average rainfall event delivers 12 mm of precipitation. For the extreme rainfall scenario, we assumed approximately half of the monthly precipitation in either of these months, which is 50 mm (Table 3.1.D-1).

Table 3.1.D-1. Precipitation and the number of days with rain in selected cities²⁷

Climate zones	Cities	May			June			Catastrophic rain, mm (50% of monthly precipitation)
		Days with rain	Precipitation, mm	Average rain, mm	Days with rain	Precipitation, mm	Average rain, mm	
Moderate cool	Sevan	12	140	12	13	157	12	79
	Hrazdan	10	113	11	10	120	12	60
	Stepanavan	11	141	13	10	130	13	65
	Vanadzor	13	177	14	13	189	15	95
	Average	12	143	12	12	149	13	75
Moderate relatively humid	Idjevan	10	127	13	8	97	12	64
	Dilijan	11	133	12	12	133	11	67
	Alaverdi	10	134	13	8	100	13	67
	Goris	9	103	11	5	63	13	52
	Average	10	124	12	8	98	12	62
Arid	Armavir	7	33	5	7	28	4	17
	Ararat	2	39	20	1	20	20	20
	Meghri	6	81	14	3	44	15	41
	Average	5	51	10	4	31	8	26
Moderate with dry summer	Gyumri	6	78	13	5	71	14	39
	Gavar	13	147	11	13	166	13	74
	Vardenis	9	109	12	9	99	11	55
	Sisian	8	112	14	7	84	12	56
	Average	9	112	12	9	105	12	56
Average		9	110	12	8	99	12	48

548
549
550
551
552
553
554
555
556
557
558
559
560

3.1.D1. ES provided by terrestrial ecosystems

The average spring rainfall scenario (12 mm)

ES maps (Figure 3.1.D1-1) show that precipitation is almost entirely retained by vegetation and soil. Quick runoff across most of Armenia is less than 1 mm, slightly exceeding this value in some valleys. Under the bare ground scenario, runoff retention (RT) reduces very slightly. Quick runoff (Q) increases slightly in absolute terms, but the relative changes in some watersheds are noticeable. The ES provided by ecosystems is estimated as the difference between the ES on current land cover 2023 and on bare ground. The influence of ecosystems on ES indicators is minor, amounting to a decrease in quick runoff by 0.01–0.08 mm and an increase in runoff retention by 1–8 liters per pixel; for the Hrazdan watershed a very small but opposite effect is observed. In relative terms, the effect on runoff retention is extremely small—everywhere under 1% of the 2023 value—and there is a widespread in the share of quick runoff changes, ranging from +55% to -3%. (Table 3.1.D1-2; Figures 3.1.D1-2 and 3.1.D1-3).

²⁶ http://releases.naturalcapitalproject.org/invest-userguide/latest/en/urban_flood_mitigation.html

²⁷ <http://armenia.pogoda360.ru>

561
562

Table 3.1.D1-2. ES indicators across watersheds under the average rainfall scenario, 12 mm (the calculations were carried out for the entire territory of Armenia)

	Indicator	Aghstev	Akhuryan	Arpa	Debed	Hrazdan	Metsamor	Vorotan
Current land cover, Esri 2023	Quick flow, mm, Q_{2023}	0.11	0.40	0.16	0.10	0.24	0.27	0.07
	Runoff retention, m^3/pix , RT_{2023}	1.19	1.16	1.18	1.19	1.18	1.17	1.19
	Total runoff retention, mln of m^3 , $RT_{2023Tot}$	37.76	32.07	52.19	46.71	70.43	42.78	53.42
Bare ground scenario	Quick flow, mm, Q_{bare}	0.19	0.41	0.16	0.16	0.26	0.26	0.13
	Runoff retention, m^3/pix , RT_{bg}	1.18	1.16	1.18	1.18	1.17	1.17	1.19
	Total runoff retention, mln of m^3 , RT_{bgTot}	37.51	32.04	52.16	46.49	70.30	42.81	53.16
Effect of terrestrial ecosystems	Reduction of quick runoff by ecosystems, mm $Q_{eco} = Q_{2023} - Q_{bg}$	-0.06	-0.08	-0.01	-0.06	0.01	-0.02	-0.01
	Share of Q reduced by ecosystems, % $Q_{eco} * 100 / Q_{2023}$	-54.88	-19.81	-3.94	-54.91	3.05	-8.13	-13.14
	Runoff retention, provided by ecosystems, m^3/pix $RT_{eco} = RT_{2023} - RT_{bg}$	0.01	0.01	0.00	0.01	0.00	0.00	0.00
	Share of RT provided by ecosystems, % $RT_{eco} * 100 / RT_{2023}$	0.50	0.69	0.05	0.47	-0.06	0.18	0.08
	Total provided runoff retention, mln of m^3 $RT_{ecoTot} = RT_{2023Tot} - RT_{bgTot}$	0.26	0.25	0.03	0.22	-0.03	0.13	0.03
	Share of total RT, provided by ecosystems $RT_{ecoTot} * 100 / RT_{2023Tot}$	0.70	0.79	0.05	0.47	-0.04	0.30	0.05

563

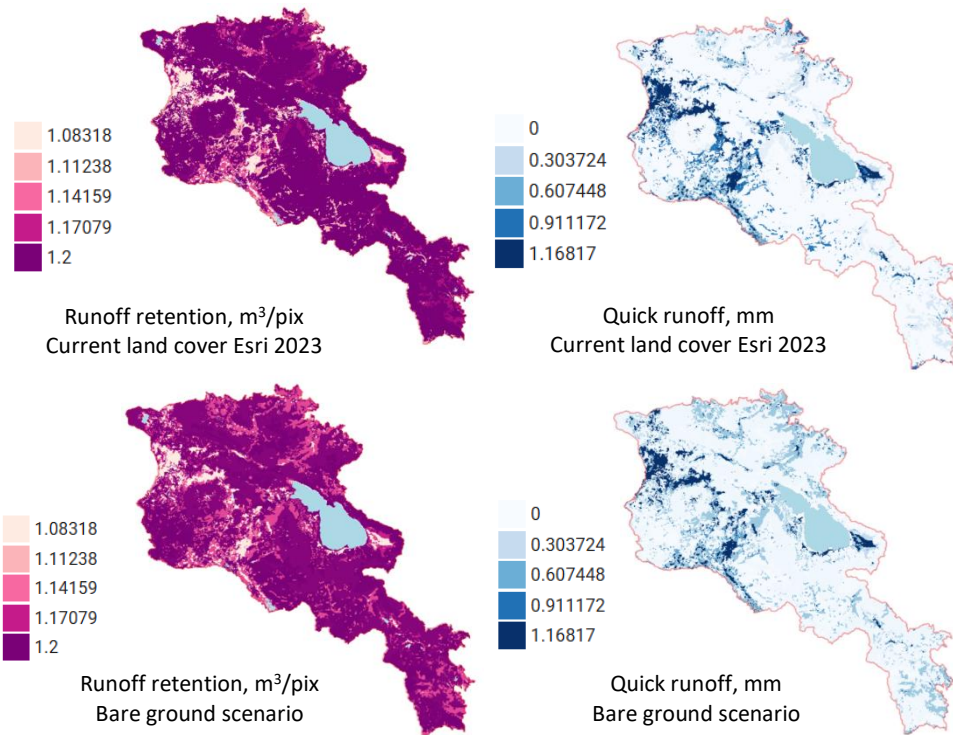

564

565

566

567

Figure 3.1.D1-1. Maps of ES indicators under the average spring rainfall scenario (12 mm). For details see project Web GIS <https://bccarmenia.nextgis.com/>, section "Ecosystem services. Urban Flood Risk Mitigation"

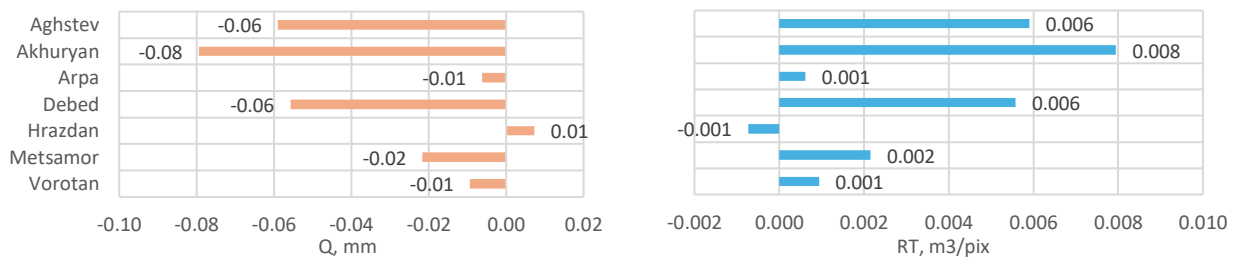

568

569

570

Figure 3.1.D1-2. Ecosystem effect on quick runoff and runoff retention across watersheds under the average spring rainfall scenario (12 mm).

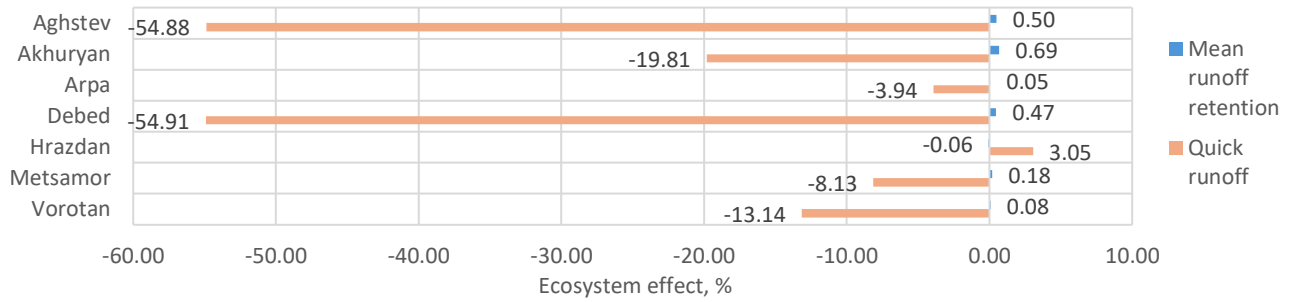

571

572 Figure 3.1.D1-3. Ecosystem effect on quick runoff and runoff retention relative to ES on current land cover (2023), %

573

The extreme spring rainfall scenario (50 mm)

574

575

576

577

578

579

580

Precipitation is fully retained only in a small part of the territory (the darkest areas on the map of runoff retention). As a result, quick runoff exceeds 10 mm across most of the territory and exceeds 20 mm in a significant portion. If all natural vegetation is replaced with bare ground, runoff retention decreases significantly, and quick runoff also increases noticeably. Unlike the average-rain scenario, under an extreme-rain event the ecosystems' influence on the ES indicators is substantial: they reduce quick runoff by an average of 4 mm (-32% relative to the value in 2023) and increase runoff retention by 0.4 m³/pix (+11% relative to the value in 2023). Totally, ecosystems increase runoff retention by 118 million of m³

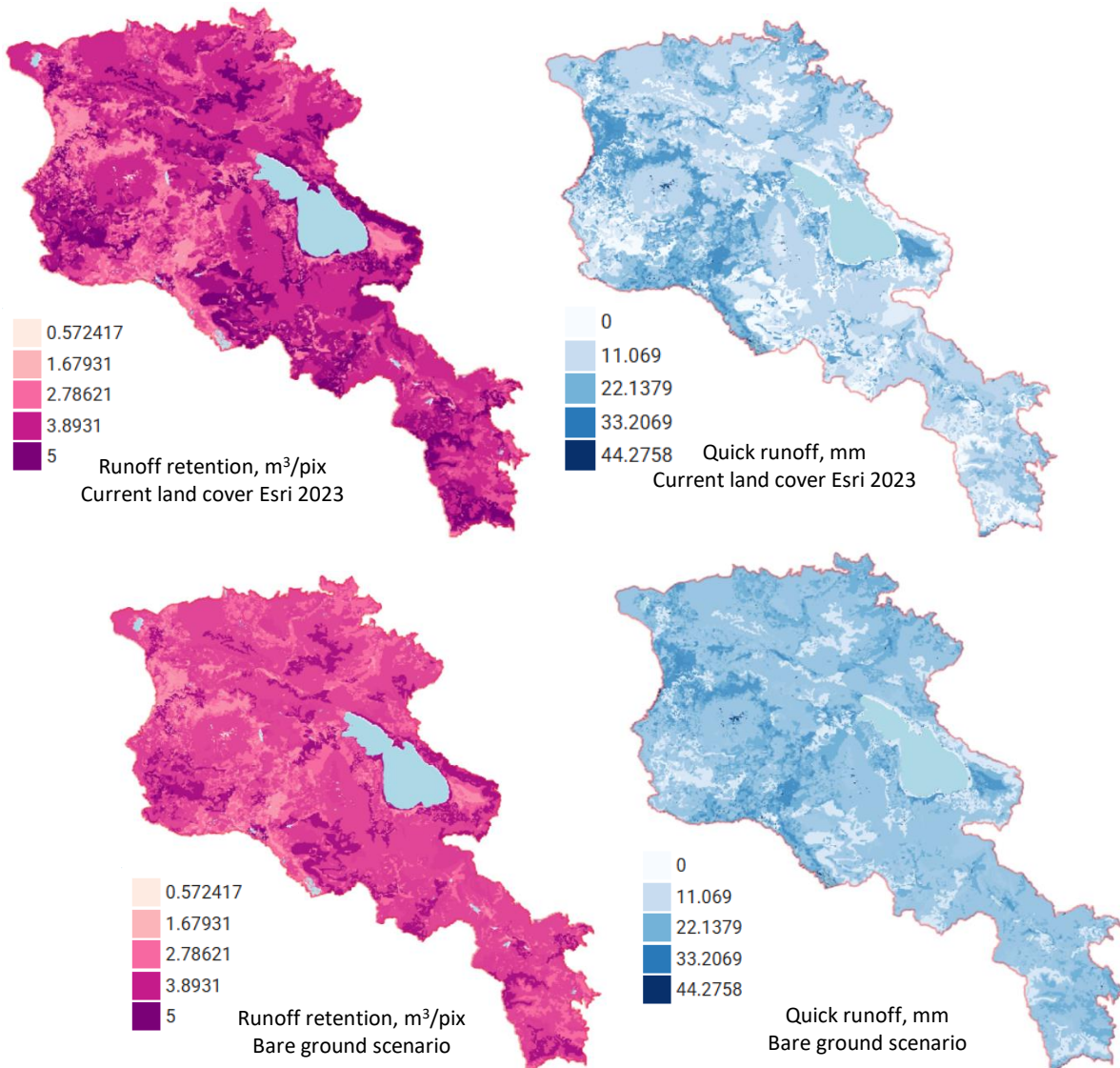

581

582

583

584

Figure 3.1.D1-4. Maps of ES indicators under the extreme spring rainfall scenario (50 mm). For details see project Web GIS <https://bccarmenia.nextgis.com/>, section "Ecosystem services. Urban Flood Risk Mitigation"

585 Ecosystems increase runoff retention across all watersheds by 0.3–0.5 m³ and reduce quick runoff by 2.9–5.3 mm
 586 (Fig. 31D1-5; Table 31D1-3). In relative terms, compared to 2023 values, the ecosystem effect is most pronounced in the
 587 Arpa and Vorotan watersheds, where runoff retention increased by 13% and quick runoff decreased by 43–49% (Fig.
 588 3.1.D1-6; Table 3.1.D1-3).

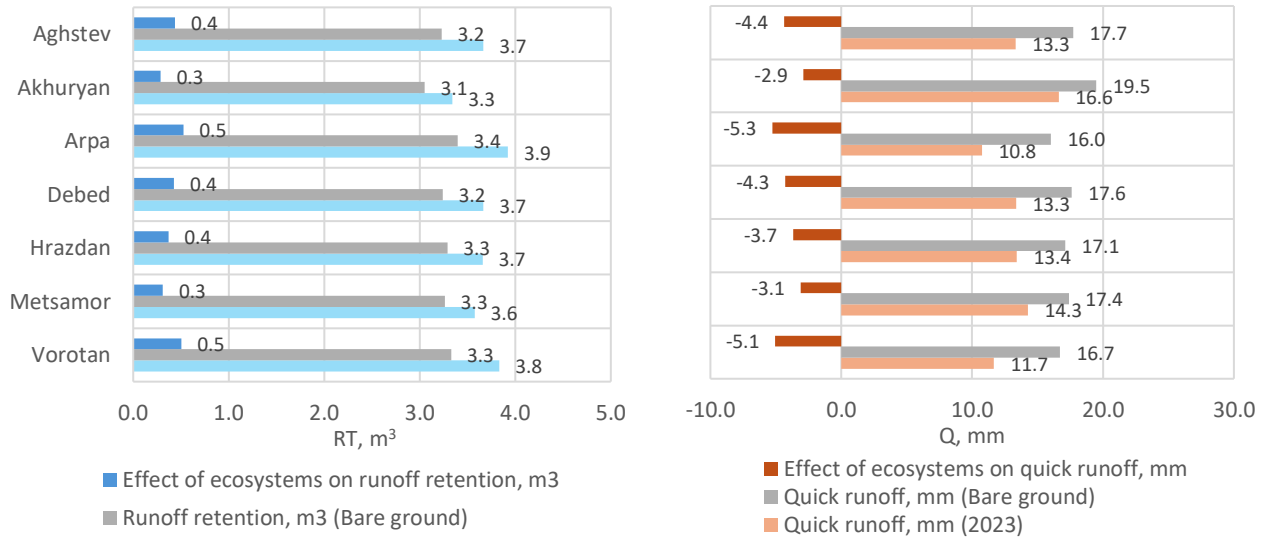

589 Figure 3.1.D1-5. ES indicators under the extreme spring rainfall scenario (50 mm) across watersheds

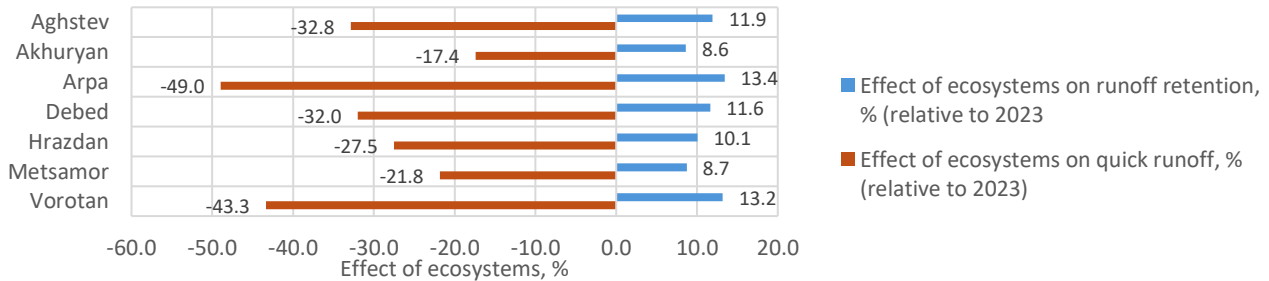

591 Figure 3.1.D1-6. Ecosystem effect: percentage change in runoff retention (R) and quick runoff (P) relative to 2023, by
 592 watershed

593 Table 3.1.D1-3. ES indicators across watersheds under the extreme rainfall scenario, 50 mm (the calculations were
 594 carried out for the entire territory of Armenia)

	Indicator	Agh-stev	Akhu-ryan	Arpa	Debed	Hrazdan	Metsam-or	Vorotan	Average or total
Current land cover, Esri 2023	Quick flow, mm, Q ₂₀₂₃	13.3	16.6	10.8	13.3	13.4	14.3	11.7	13.3
	Runoff retention, m ³ /pix, RT ₂₀₂₃	3.7	3.3	3.9	3.7	3.7	3.6	3.8	3.7
	Total runoff retention, million m ³ , RT _{2023Tot}	116	92	173	144	219	130	172	1047
Bare ground scenario	Quick flow, mm, Q _{bare}	17.7	19.5	16.0	17.6	17.1	17.4	16.7	17.4
	Runoff retention, m ³ /pix, RT _{bg}	3.2	3.1	3.4	3.2	3.3	3.3	3.3	3.3
	Total runoff retention, million m ³ , RT _{bgTot}	103	84	150	127	197	119	149	929
Effect of eco-systems	Reduction of quick runoff by ecosystems, mm Q _{eco} = Q ₂₀₂₃ - Q _{bg}	-4.4	-2.9	-5.3	-4.3	-3.7	-3.1	-5.1	14.1
	Share of Q reduced by ecosystems, % Q _{eco} * 100 / Q ₂₀₂₃	-32.8	-17.4	-49.0	-32.0	-27.5	-21.8	-43.3	-32.0
	Runoff retention provided by ecosystems, m ³ /pix RT _{eco} = RT ₂₀₂₃ - RT _{bg}	0.4	0.3	0.5	0.4	0.4	0.3	0.5	0.4
	Share of RT provided by ecosystems, % RT _{eco} * 100 / RT ₂₀₂₃	11.9	8.6	13.4	11.6	10.1	8.7	13.2	11.1
	Total runoff retention, provided by ecosystems, million m ³ RT _{ecoTot} = RT _{2023Tot} - RT _{bgTot}	14	8	23	17	22	11	23	118
	Share of total RT, provided by ecosystems RT _{ecoTot} * 100 / RT _{2023Tot}	11.9	8.6	13.4	11.6	10.1	8.7	13.2	11.3

596 Further analysis was conducted only for natural areas, excluding croplands and built-up areas.

597 *Table 3.1.D1-4. Runoff retention provided by ecosystems across marzes and vegetation types*

	Marzes	Alpine vegetation	Subalpine meadows	Meadow-steppe	Steppe	Grasslands in forest	Forests	Juniper	Broadleaf woodland	Semidesert	Desert	Marsh	Average
RT m ³ /ha	Aragatsotn	49.70	50.64	36.88	46.23	31.30	48.13	0.00	0.00	56.77	0.00	-16.59	47.91
	Ararat	44.06	57.30	43.16	61.04	50.46	53.11	0.00	42.63	55.78	67.01	36.49	56.60
	Armavir	0.00	0.00	0.00	0.00	0.00	23.13	0.00	0.00	51.91	0.00	24.22	51.43
	Gegharkunik	51.26	57.04	50.41	49.53	51.75	60.89	70.18	2.11	0.00	0.00	44.19	53.19
	Kotayk	76.28	64.27	53.72	30.94	60.25	46.34	0.00	27.59	24.49	0.00	30.19	45.90
	Lori	43.04	48.75	45.22	50.83	53.36	47.99	0.00	58.48	0.00	0.00	47.16	48.88
	Shirak	42.90	49.35	47.29	41.09	0.00	57.80	0.00	0.00	51.83	0.00	30.54	44.57
	Syunik	55.89	62.98	47.43	46.71	59.13	44.28	54.45	72.66	60.46	0.00	31.33	54.56
	Tavush	90.08	54.84	0.00	43.06	48.74	44.46	0.00	29.40	0.00	0.00	0.00	43.37
	Vayots Dzor	77.05	54.41	89.59	61.60	55.57	49.85	61.14	59.83	57.98	0.00	39.68	61.28
	Average	56.61	55.63	47.06	49.50	54.36	46.38	61.94	40.44	51.49	67.01	39.96	47.91
													Total
Total RT, millions of m ³	Aragatsotn	1.02	0.54	1.85	2.39	0.13	0.24	0.00	0.00	4.24	0.00	-0.01	10.40
	Ararat	0.16	0.36	0.13	4.48	0.89	0.14	0.00	0.04	2.48	0.05	0.18	8.91
	Armavir	0.00	0.00	0.00	0.00	0.00	0.00	0.00	0.00	2.33	0.00	0.02	2.35
	Gegharkunik	2.00	7.31	2.02	4.05	1.17	0.78	0.15	0.00	0.00	0.00	0.41	17.88
	Kotayk	0.87	1.13	1.19	1.40	1.64	0.72	0.00	0.00	0.68	0.00	0.02	7.66
	Lori	0.19	4.13	2.94	1.71	2.81	4.32	0.00	0.24	0.00	0.00	0.15	16.50
	Shirak	0.55	1.99	1.96	3.39	0.00	0.08	0.00	0.00	0.09	0.00	0.09	8.14
	Syunik	2.93	5.12	1.38	3.65	5.16	2.16	0.07	1.06	0.67	0.00	0.02	22.21
	Tavush	0.00	1.16	0.00	0.03	2.60	5.97	0.00	1.42	0.00	0.00	0.00	11.19
	Vayots Dzor	1.62	2.10	0.70	4.70	1.37	0.19	0.59	0.03	2.11	0.00	0.00	13.41
	Total	9.35	23.84	12.16	25.79	15.77	14.59	0.80	2.80	12.60	0.05	0.88	118.64

598 As seen in Table 3.1.D1-4, per-hectare values of runoff retention (RT) differ only modestly across vegetation types.
 599 The total RT volume is highest in the marzes of Syunik and Gegharkunik, where mountain grasslands make a substantial
 600 contribution in both cases. The total RT volume is lowest in Armavir marz (Figure 3.1.D1-7). Among vegetation types,
 601 steppe and subalpine meadows provide the largest total contribution. The smallest contribution comes from open
 602 woodlands, deserts, and marshes due to their limited area (Figure 3.1.D1-8).
 603

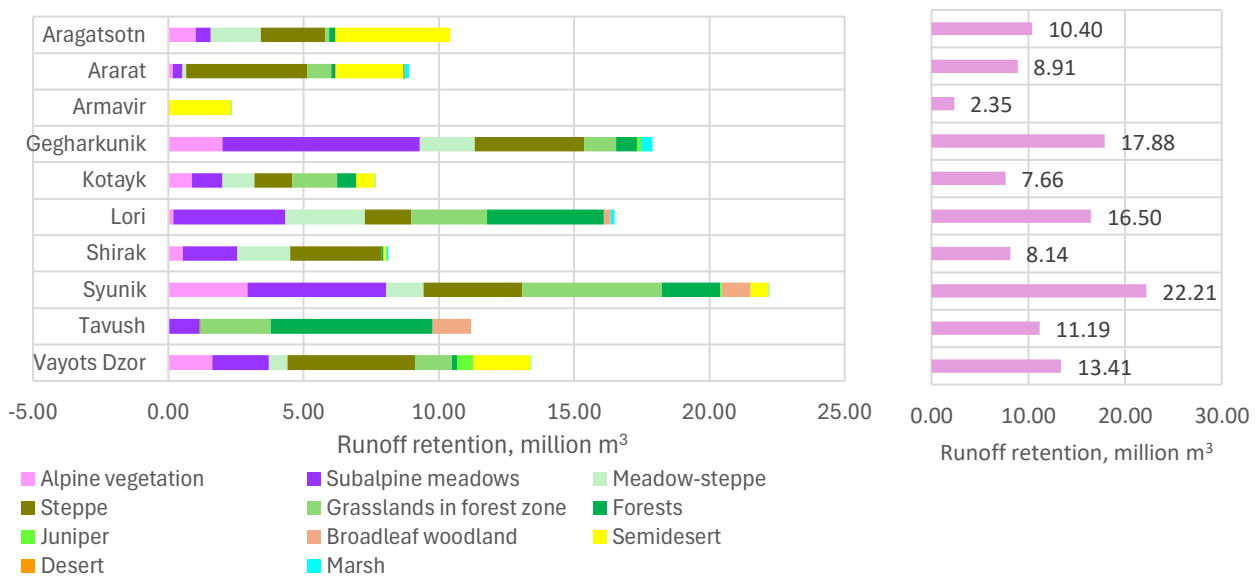

604 *Figure 3.1.D1-7. Total runoff retention provided by ecosystems across marzes, million m³*

605

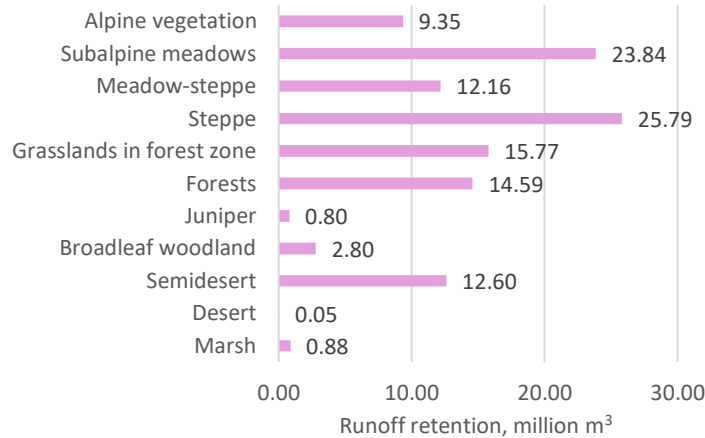

Figure 3.1.D1-8. Total runoff retention provided by different vegetation types, million m³

3.1.D2. Changes in potential ES (extreme rainfall scenario, 50 mm)

Assessment of ES changes based on the 2017 and 2023 modelled ES maps

606
607
608
609
610
611
612
613
614
615
616

Land-cover changes from 2017 to 2023, as captured in Esri data, resulted in negative changes across all watersheds except Arpa. The most pronounced negative changes are modeled for the Akhuryan watershed, where runoff retention decreased by 1.5% and quick runoff increased by 3.8%. In the other watersheds (except Arpa), runoff retention decreased by 0.1–0.7%, while quick runoff increased by 0.3–1.5% (Figure 3.1.D2-1; Table 3.1.D2-1). Changes in ES at the marz level mirror those at the watershed level. The changes are negative everywhere except in Vayots Dzor marz. The most pronounced negative changes are modeled for Shirak marz, which lies within the Akhuryan watershed (Figure 3.1.D2-2; Table 3.1.D2-1).

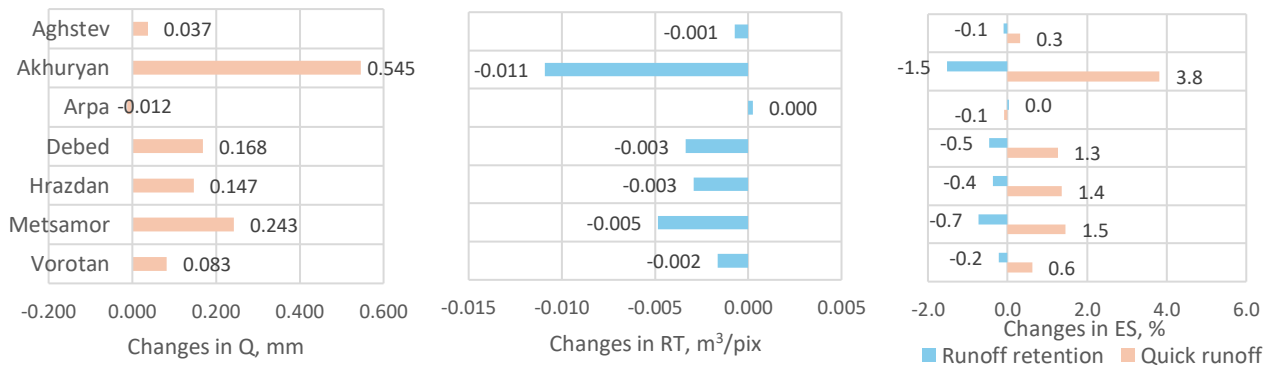

617
618

Figure 3.1.D2-1. Changes in ES under the extreme rainfall scenario (50 mm) from 2017 to 2023 across watersheds

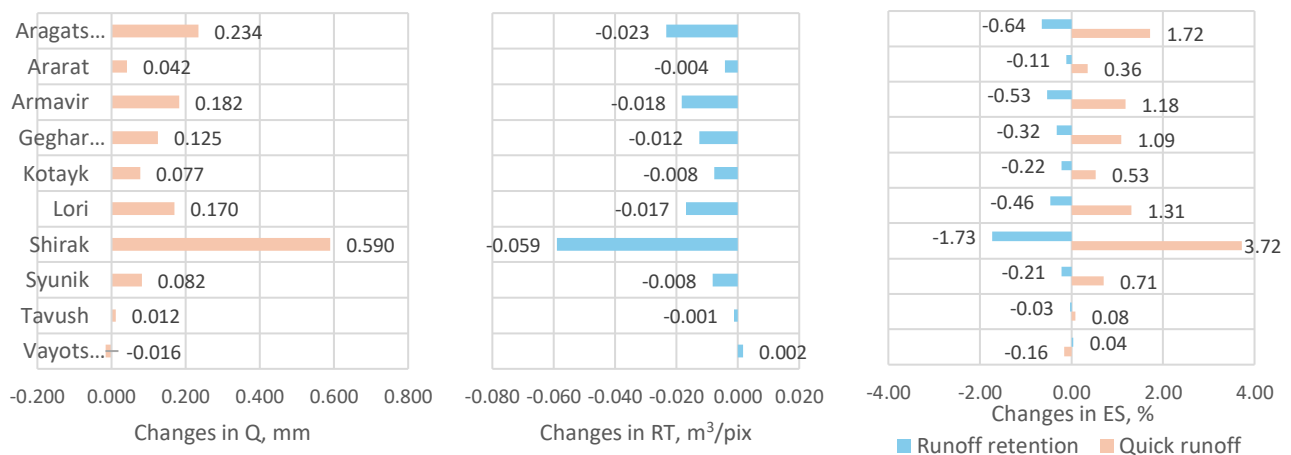

619
620

Figure 3.1.D2-2. Changes in ES under the extreme rainfall scenario (50 mm) from 2017 to 2023 across marzes

621
622

Table 3.1.D2-1. Changes in ES under the extreme rainfall scenario (50 mm) from 2017 to 2023 (the calculations were carried out for the entire territory of Armenia)

EAA		Changes in absolute terms		Changes relative to the values in 2017, %	
		Quick runoff, Q, mm	Runoff retention, RT, m ³ /pix	Quick runoff, Q	Runoff retention, RT
Watersheds	Aghstev	0.037	-0.001	0.315	-0.096
	Akhuryan	0.545	-0.011	3.822	-1.526
	Arpa	-0.012	0.000	-0.091	0.034
	Debed	0.168	-0.003	1.262	-0.460
	Hrazdan	0.147	-0.003	1.362	-0.373
	Metsamor	0.243	-0.005	1.461	-0.727
	Vorotan	0.083	-0.002	0.619	-0.225
Marzes	Aragatsotn	0.082	-0.008	0.706	-0.213
	Ararat	-0.016	0.002	-0.157	0.041
	Armavir	0.042	-0.004	0.357	-0.110
	Gegharkunik	0.182	-0.018	1.180	-0.527
	Kotayk	0.125	-0.012	1.089	-0.324
	Lori	0.662	-0.066	2.901	-2.438
	Shirak	0.234	-0.023	1.720	-0.643
	Syunik	0.077	-0.008	0.532	-0.217
	Tavush	0.590	-0.059	3.722	-1.728
Vayots Dzor	0.012	-0.001	0.084	-0.033	

623
624
625
626
627
628
629
630
631

Using this ES as a case study, we tested the feasibility of assessing ES loss resulting from the historical conversion of natural grasslands by humans. The loss was assessed as the difference between the ES indicator values for the 2023 land cover and for a fully natural land-cover scenario in which all croplands and built-up areas are replaced by grasslands. ES loss is greatest—both in absolute and relative terms—in the Akhuryan watershed (a 5% decrease in runoff retention and a 10% increase in quick runoff), and smallest in the Arpa watershed (−0.7% and +2.7%, respectively) (Figure 3.1.D2-3). Nonetheless, the results suggest that the ES has been mostly retained. As expected, the most significant loss of ES occurred in areas that are currently built-up where quick runoff increased the most, by 49%. For croplands, the ES loss is less substantial (Figure 3.1.D2-4).

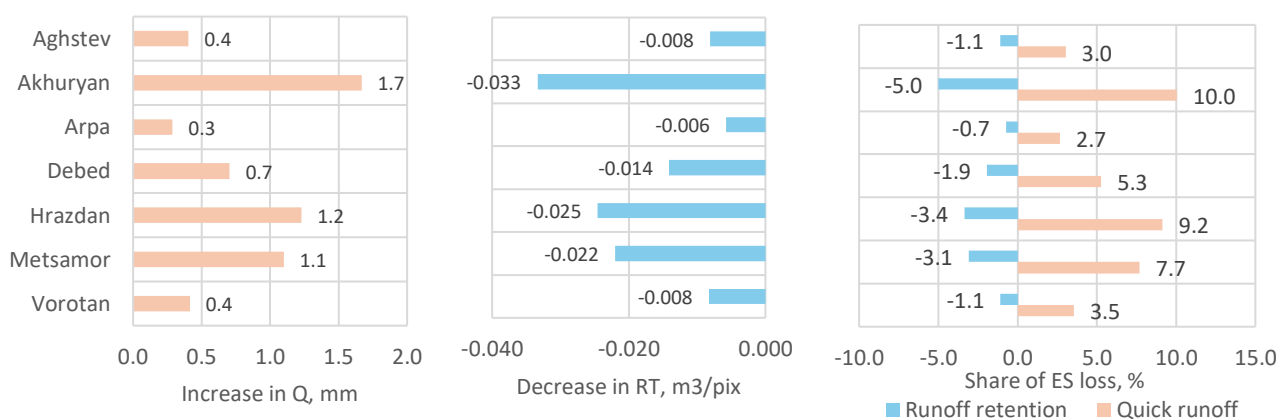

632
633

Figure 3.1.D2-3. ES loss resulting from the historical conversion of natural grasslands by humans

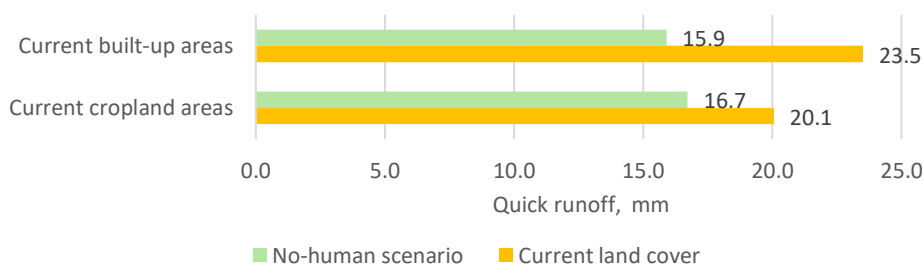

634
635

Figure 3.1.D2-4. ES loss in built-up areas and in croplands

Assessment of ES changes based on the changes in area of vegetation types

Changes in potential ES can be assessed on the basis of changes in area of vegetation types from accounting table for ecosystem extent (Table 2.3.C-2) using the indicators of ES provisioning per ha across different vegetation types in 2023 (Table 3.1.D1-4). In this calculation, we did not take into account the changes in per-hectare ES potential values between 2017 and 2023. This approach makes it possible to calculate the data for the table recording the dynamics of the ES potential/capacity (Table 3.1.D2-2).

With respect to changes in ES potential/capacity, the same comment applies as for changes in ecosystem extent (Section 2.3.A). Additions to ecosystem area resulting from transitions out of croplands or built-up areas do not possess full ecosystem functionality. Therefore, the closing ES capacity is defined more by the extent of ecosystems that remained untransformed during the reporting period than by the total closing ecosystem area.

Table 3.1.D2-2. Accounting table for the changes in ES potential, million m³

	Alpine vege- tation	Subalpine meadows	Meadow- steppe	Steppe	Grassl. in forest zone	Forests	Juniper	Broadleaf woodland	Semi-desert	Desert	Marsh	Total
Opening ES capacity in 2017	9.32	23.92	13.37	26.95	15.49	15.21	0.80	2.87	12.76	0.05	0.95	121.69
Additions to ES capacity	0.03	0.43	0.17	0.96	1.46	1.07	0.01	0.23	0.99	0.00	0.07	5.42
Managed/unmanaged	NA											
Reductions ES capacity	0.02	0.47	1.36	2.00	1.21	1.72	0.01	0.28	1.05	0.00	0.10	8.21
Managed/unmanaged	NA											
Net change ES capacity	0.01	-0.04	-1.20	-1.04	0.25	-0.64	0.01	-0.05	-0.06	0.00	-0.02	-2.79
Closing ES capacity in 2023	9.33	23.89	12.18	25.90	15.75	14.57	0.80	2.82	12.71	0.05	0.92	118.91
Closing ES capacity in 2023 of ecosystems unconverted since 2017,	9.30	23.46	12.01	24.95	14.29	13.50	0.79	2.59	11.71	0.05	0.85	113.49

647

648

649

3.1.E. Cooling effect of terrestrial ecosystems (InVEST Urban Cooling)

650

3.1.E1. Methodological issues

651

InVEST model Urban Cooling Effect²⁸ is primarily aimed at assessing the cooling effect of green spaces within urban areas. However, it also allows for evaluating this effect over large areas outside of cities. Since the assessment of urban ecosystem services is not a goal of our project, we focused primarily on the entire territory of Armenia and its impact on settlements. Green spaces within settlements were not the focus of the assessment. The InVEST Urban Cooling model calculates an index of heat mitigation based on cooling capacity of green spaces and distance from them. The model computes the cooling capacity (CC) index for each pixel based on local shade, evapotranspiration, and albedo. CC is used to estimate temperature reduction by ecosystems. Heat Mitigation index (HM) estimates the cooling effect of large green spaces (>2 ha) on surrounding urban areas. In our case, it shows the impact of the surrounding area on the settlements. HM is equal to CC if the pixel is unaffected by any large green spaces but otherwise set to a distance-weighted average of the CC values from the large green spaces and the pixel of interest.

661

The model calculations are based on indicators of evapotranspiration, albedo, the proportion of area in LULC classes that is covered by tree canopy (shade), air temperature in a rural reference area, and the UHI Effect (Urban Heat Index). The last coefficient shows the difference between the rural reference temperature and the maximum temperature observed in the city. UHI is incorporated into the model as a single value. Calculations based on a single UHI value for all of Armenia are impractical due to the significant variation in conditions across different cities. Thermal images (Landsat 8 Surface temperature data courtesy of the U.S. Geological Survey; Scene ID: LC08_L2SP_170032_20240823_02_T1) show that during the hottest period (August), Yerevan is cooler than the surrounding areas, Gyumri has approximately the same temperature, and Dilijan is warmer (Figures 3.1.E-1 – 3.1.E-3). Data from Global Surface UHI Explorer²⁹ confirm that there is no single UHI coefficient for Armenia. The coefficient varies not only from city to city (Yerevan is cooler, Gyumri is warmer than surrounding area) but also across different parts of the same city (Figures 3.1.E-4). Therefore, we used UHI=0, meaning we did not account for the influence of this factor.

670

671

672

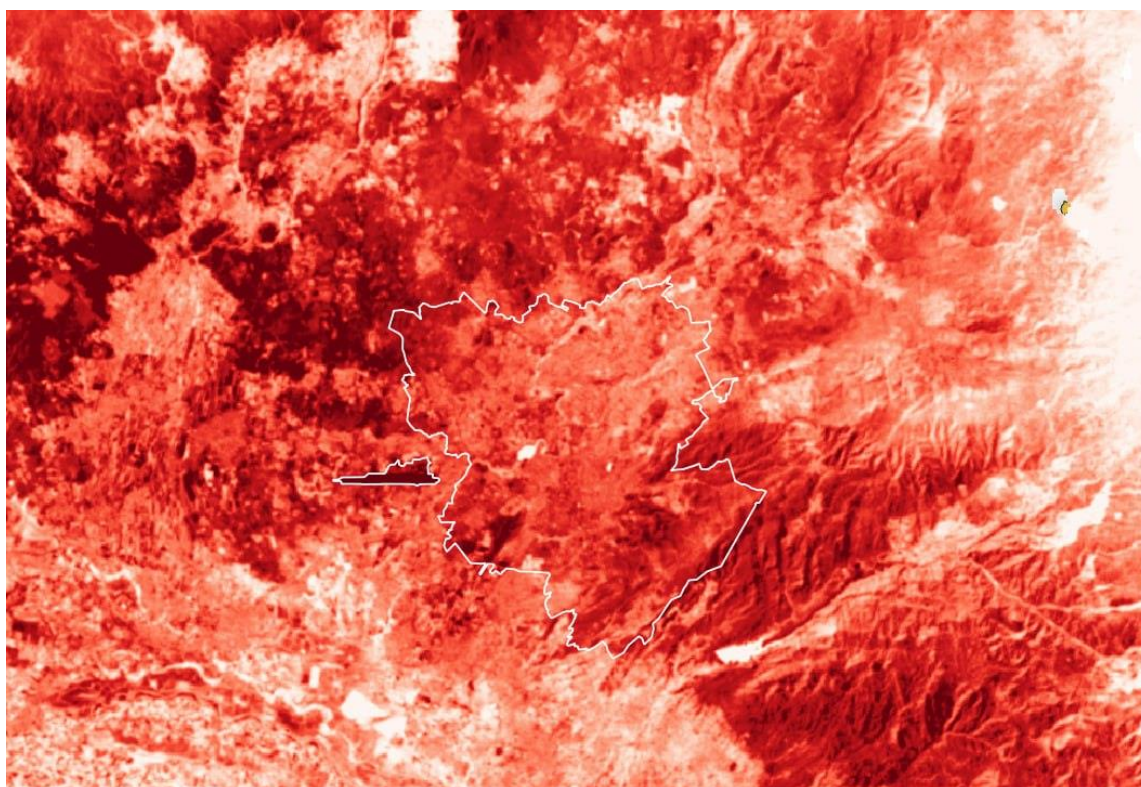

673

674

Figure 3.1.E-1. Thermal image of Yerevan

²⁸ http://releases.naturalcapitalproject.org/invest-userguide/latest/en/urban_cooling_model.html

²⁹ Yale Center for Earth Observation (YCEO); https://yceo.users.earthengine.app/view/uhiemap?utm_source=chatgpt.com

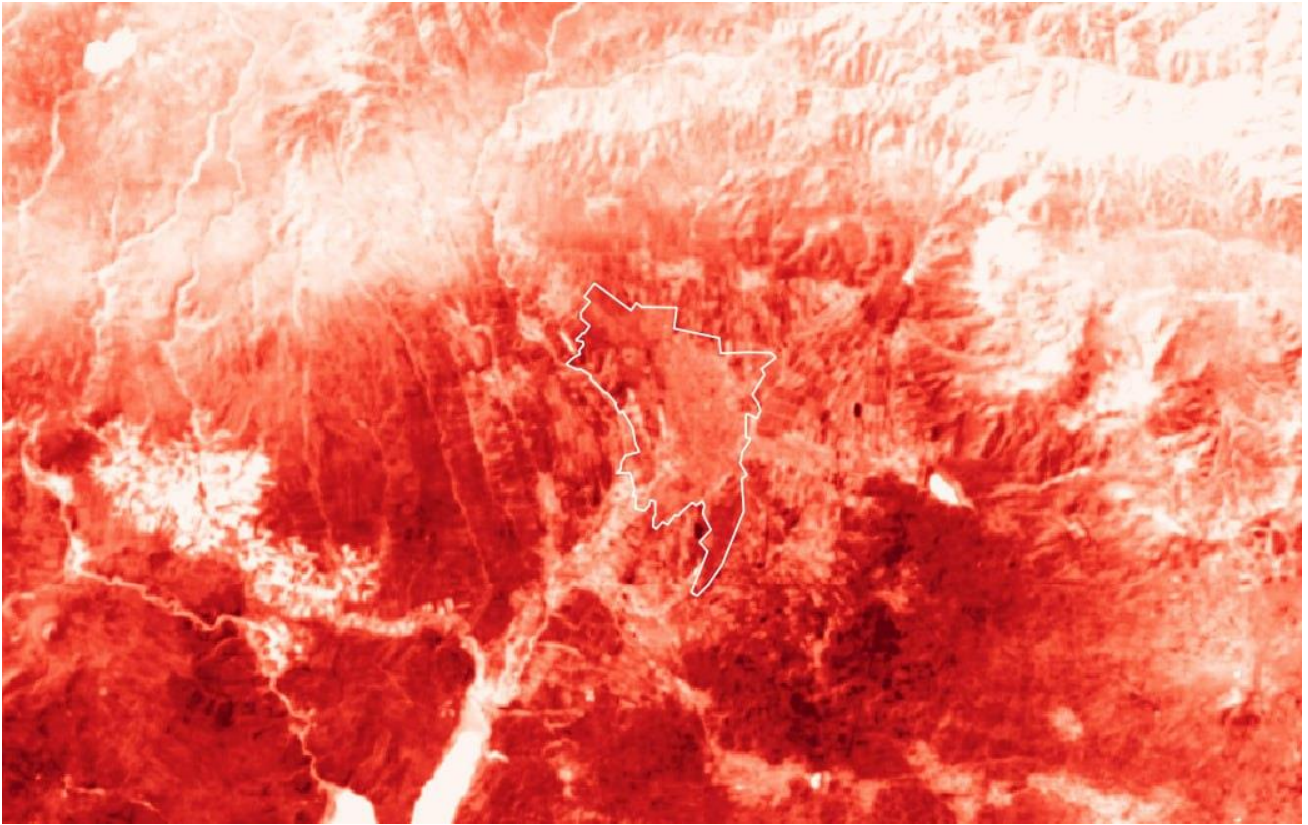

Figure 3.1.E-2. Thermal image of Gyumri

675
676
677

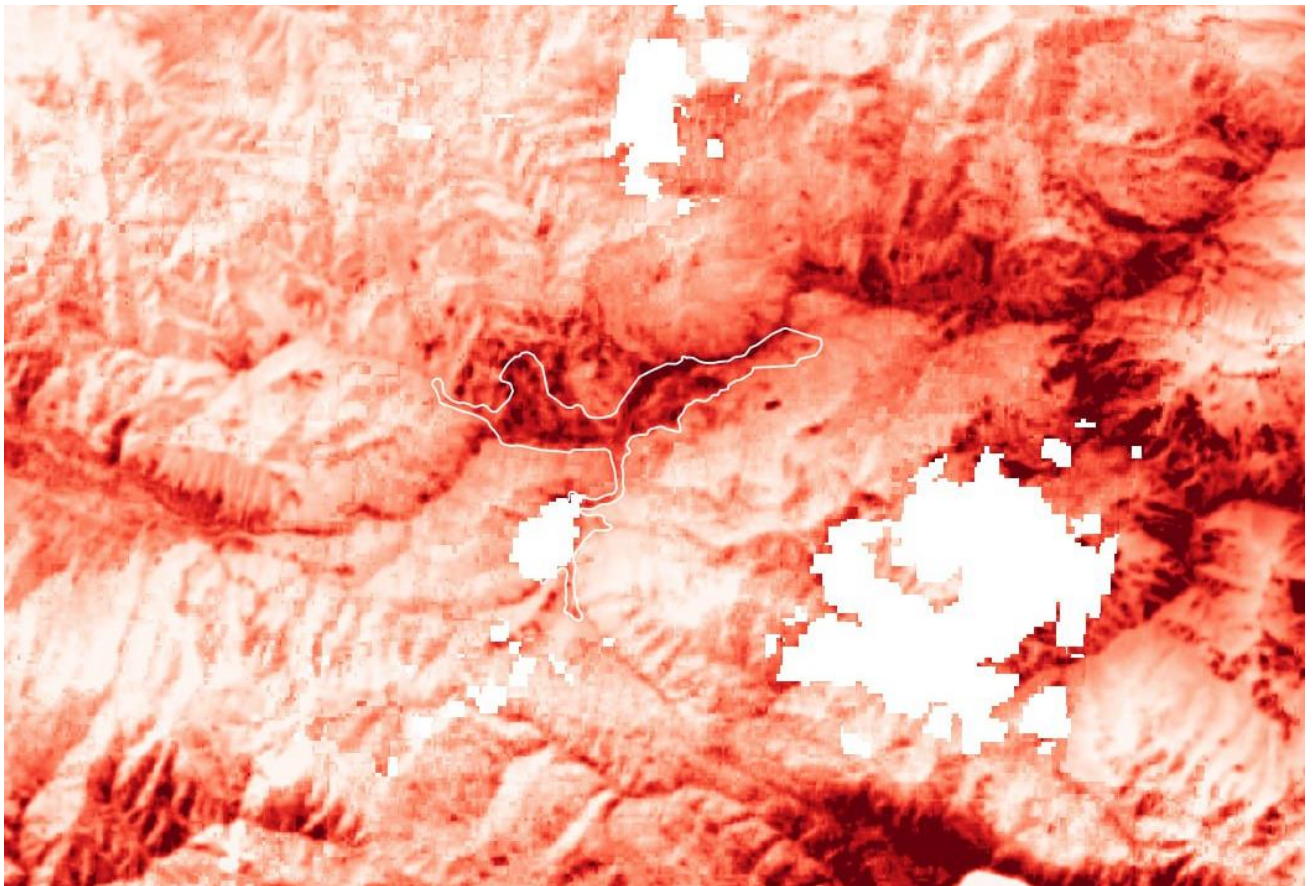

Figure 3.1.E-3. Thermal image of Dilijan

678
679

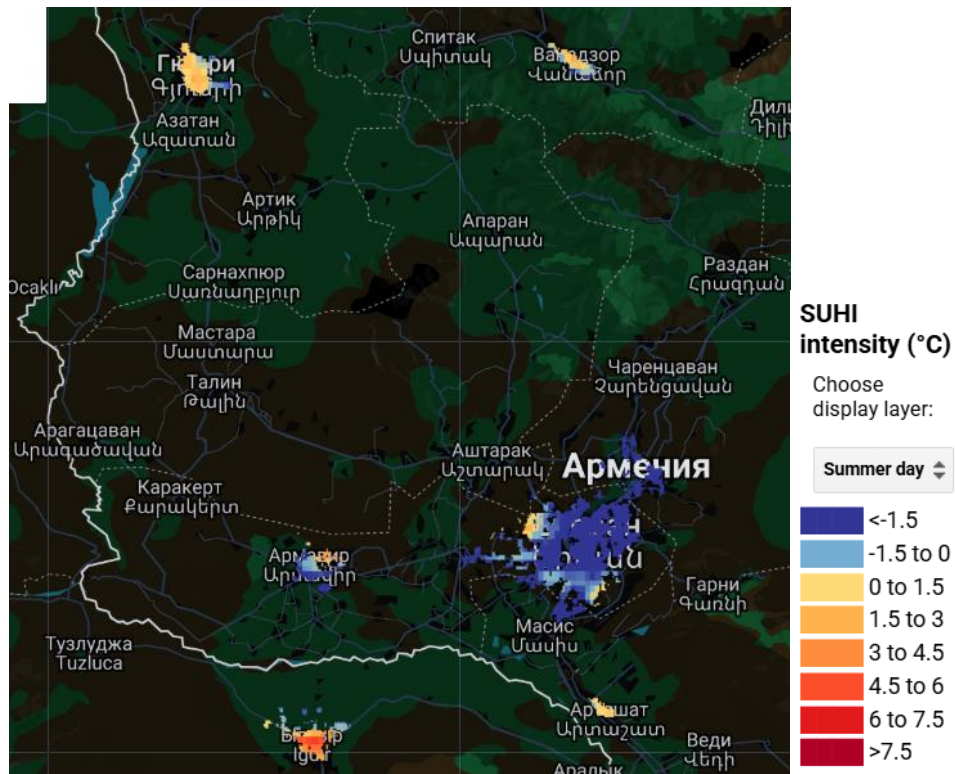

Figure 3.1.E-4. UHI values in summer (western part of Armenia)

3.1.E2. ES provided by terrestrial ecosystems

Estimates of Cooling Capacity (CC) of land cover classes are based on the balance between coefficients of albedo, evapotranspiration cooling, and shadow (i.e., the proportion of area covered by tree canopy). The Kc and albedo coefficients, applied in accordance with InVEST recommendations, yielded the following CC values for land-cover classes (Table 3.1.E2-1; Figure 3.1.E2-1):

- The highest CC is associated with forests due to high evapotranspiration cooling.
- The high CC values for croplands in arid and humid climate zones are explained by the large proportion of orchard areas in those regions (according to Armstat data). CC of croplands in moderate dry and cool climate zones where orchards are scarce, is much lower, approaching the values for bare ground and grasslands.
- The relatively high CC values for built-up areas are due to our assumption that, on average, 20% of the area in settlements is covered by trees (shadow=0.2). Increasing the area of tree cover in settlements will increase CC of built-up areas; decreasing it will reduce CC.
- CC of grasslands is lower than that of bare ground in three of the four climatic zones, and only slightly higher in the humid zone.

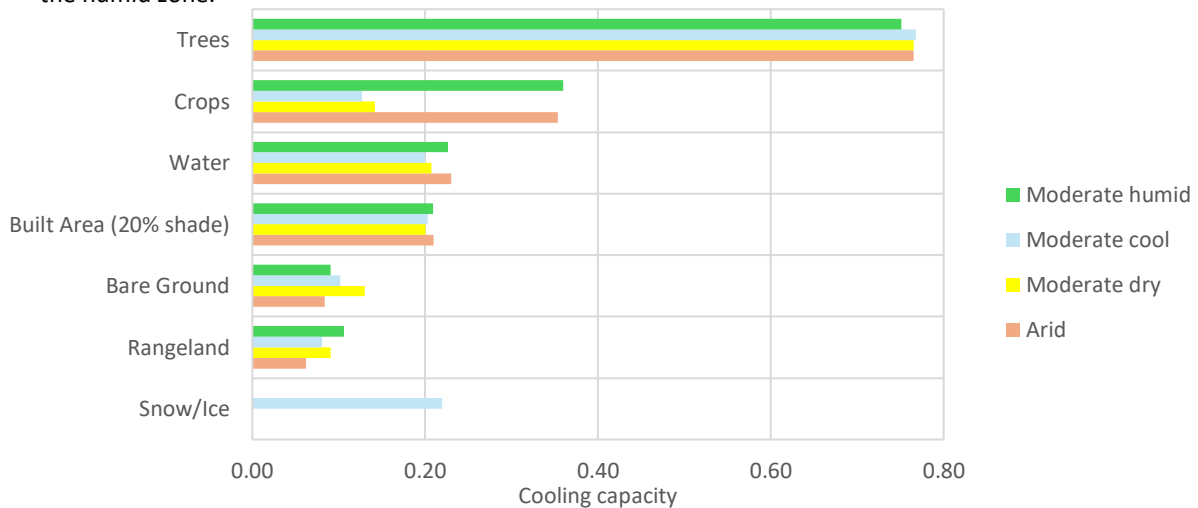

Figure 3.1.E2-1. Cooling capacity of land cover classes in different climate zones

680
681

682

683

684

685

686

687

688

689

690

691

692

693

694

695

696

697

698

Table 3.1.E2-1. Cooling capacity of land cover classes in different climate zones

	Arid zone	Moderate dry zone	Moderate cool zone	Moderate humid zone
Snow/Ice			0.22	
Rangeland	0.06	0.09	0.08	0.11
Bare Ground	0.08	0.13	0.10	0.09
Built Area (20% shade)	0.21	0.20	0.20	0.21
Water	0.23	0.21	0.20	0.23
Crops	0.35	0.14	0.13	0.36
Trees	0.77	0.77	0.77	0.75

699

700

701

702

703

704

The ES provided by natural terrestrial ecosystems was estimated as the difference in indicator values between the 2023 land cover and a bare-ground scenario. In the bare-ground scenario, CC decreases markedly over areas that are currently forested and increases slightly over areas that are currently grassland in moderate cool, dry, and arid zones. Natural vegetation yields substantial cooling in forested areas, slight cooling in grasslands in moderate humid zones and slight warming in grasslands in other zones (Fig. 31E2-2). For the discussion, see below in Section 3.5.

705

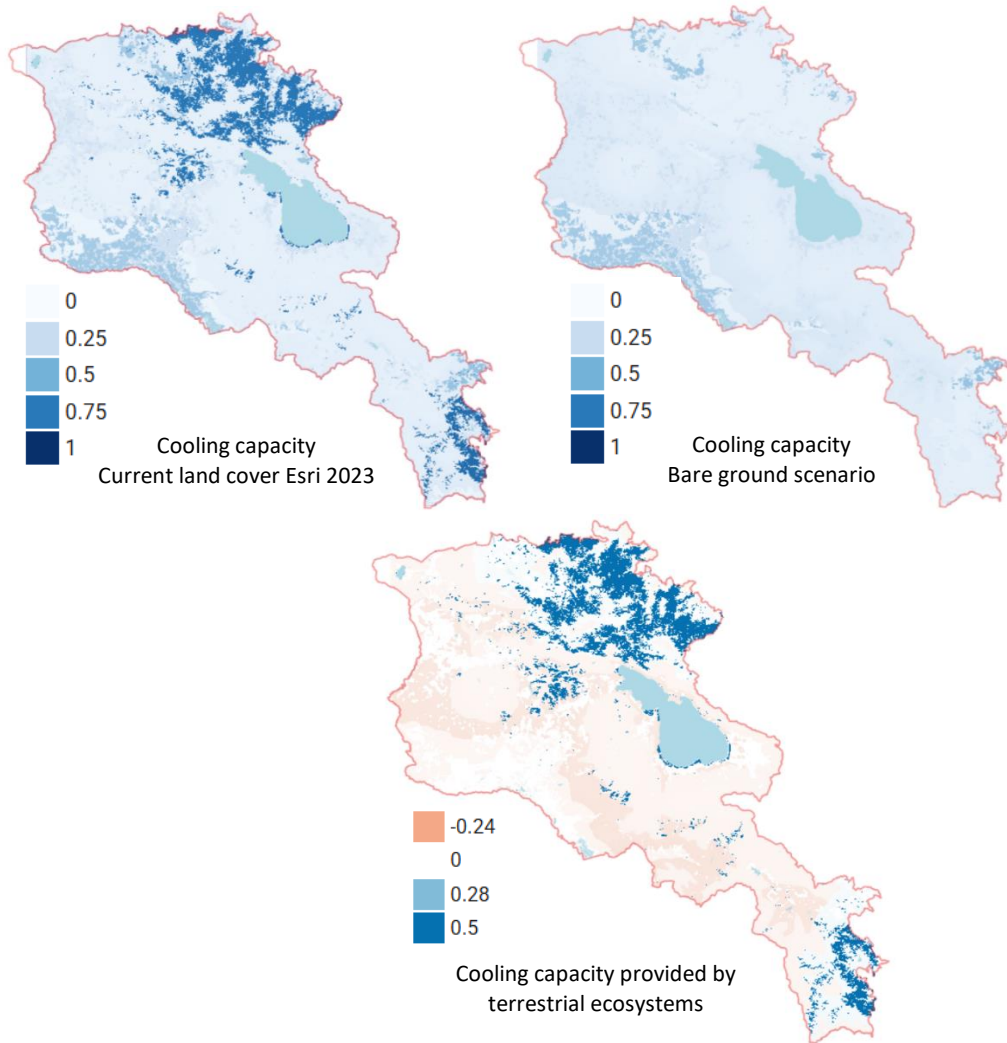

706

707

708

Figure 3.1.E2-2. Maps of cooling capacity. For details see project Web GIS <https://bccarmenia.nextgis.com/>, section "Ecosystem services. Urban Cooling"

709

710

711

712

Natural vegetation cools the marzes Tavush, Lori, Syunik, and Kotayk and slightly warms marzes that lack forests. In the marzes Tavush and Lori, where forest area is substantial, forest increases CC by 77% and 57%, respectively (Figure 3.1.E2-3). On average in Armenia, CC for the current land cover is 0.19, while for the bare-ground scenario it is 0.15; thus, ecosystems on average cool the land surface, raising CC by 0.04 (21%).

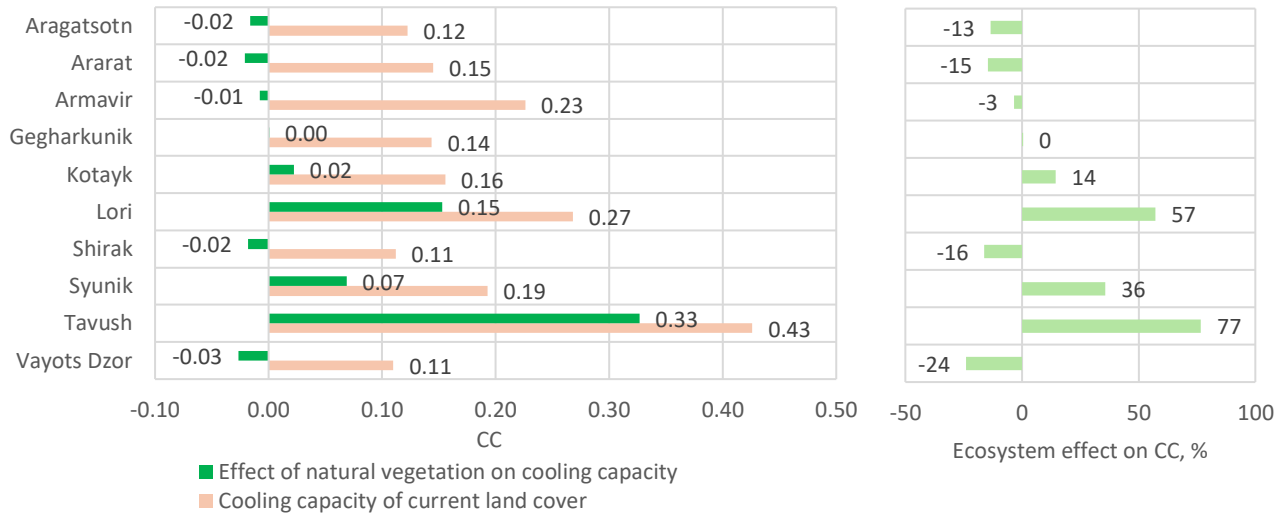

713

714 *Figure 3.1.E2-3. Cooling capacity of the current land cover and the effect of natural vegetation on cooling capacity*

715 Since we did not assess ES within settlements, our estimate concerns the influence of surrounding ecosystems on CC
 716 within settlements, assuming a uniform 20% tree-cover (shade) for all settlements. Heat Mitigation index (HM) estimates
 717 the cooling effect of large green spaces (>2 ha) on surrounding urban areas. In our case, it shows the impact of the
 718 surrounding area on the settlements. HM is equal to CC if the pixel is unaffected by any large green spaces but otherwise
 719 set to a distance-weighted average of the CC values from the large green spaces and the pixel of interest (Figure 3.1.E2-4).

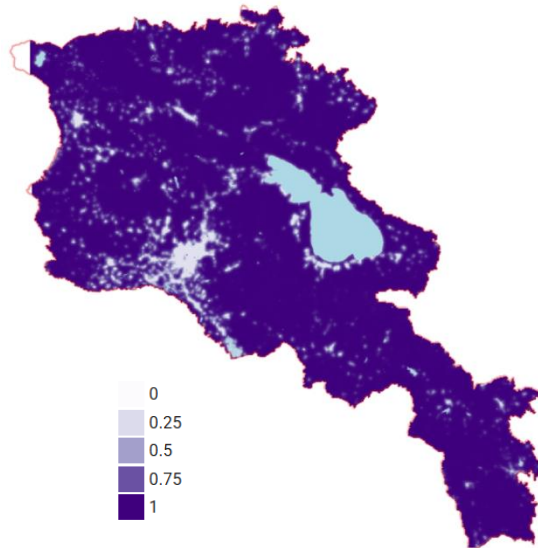

720

721 *Figure 3.1.E2-4. Heat Mitigation index. For details see project Web GIS <https://bccarmenia.nextgis.com/>, section*
 722 *"Ecosystem services. Urban Cooling"*

723 The cooling/warming effect of the surrounding ecosystems will depend on the CC of ecosystems, as well as by the
 724 geometry of the settlement boundaries, i.e., the proportion of the settlement's area influenced by the surrounding
 725 territory. Following the InVEST recommendation, we set the maximum cooling distance—the distance over which green
 726 areas larger than 2 ha exert a cooling effect—at 450 m. Across the 1,016 assessed settlements, average CC ranges from
 727 0.06 to 0.50, i.e., half of the maximum possible value (Appendix 3.1.E-1). The effect of ecosystems on CC within
 728 settlements was calculated as the difference between CC values under the current land cover and under a bare-ground
 729 scenario. In most settlements (729, or 72% of those assessed), the surrounding ecosystems produce virtually no change
 730 in CC relative to bare ground. In 133 settlements (13%), the ecosystems reduce CC, i.e., exert a warming effect; these are
 731 evidently settlements surrounded by grasslands in one of three climatic zones—moderately dry, cold, or arid. In 154
 732 settlements (15%), ecosystems increase CC, i.e., exert a cooling effect; these settlements are surrounded by forests or by
 733 grasslands in the moderately humid zone. For 20 settlements surrounded by forest, including Dilijan, Jermuk,
 734 Tsakhkadzor, the cooling effect is especially noticeable, increasing CC by 0.10–0.35 (Figure 3.1.E2-5; Appendix 3.1.E-2).



Figure 3.1.E2-5. The effect of surrounding ecosystems on CC within settlements

735

736

737 As noted earlier, the CC of different vegetation types varies across climatic zones due to different cooling effects from
 738 evaporation (Figure 3.1.E2-1). Therefore, the CC of different vegetation types varies across marzes because of differences
 739 in the area of climatic zones across marzes (Table 3.1.E2-2). Overall, forests in Armenia have the highest cooling CC.
 740 Broadleaf woodlands and grasslands within the forest zone also provide a slight cooling effect. According to the
 741 coefficients used for modeling, other vegetation types, on the contrary, have a very weak, but still warming effect
 742 compared to bare ground (Figure 3.1.E2-6 a). The average CC in marzes, if only natural vegetation is taken into account,
 743 differs from the average for the entire territory, essentially repeating the effect of natural vegetation (compare Figure
 744 31E2-3 and Figure 31E2-6 b).

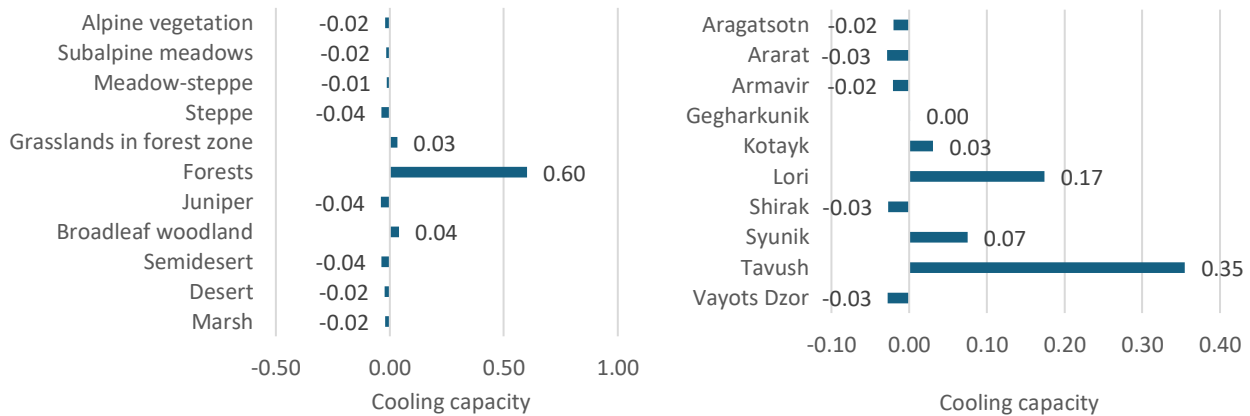

Figure 3.1.E2-6. Cooling capacity of different vegetation types (a) and across marzes (b)

745

746

747

748

Table 3.1.E2-2. Cooling capacity of different vegetation types across marzes

	Alpine vegetation	Subalpine meadows	Meadow-steppe	Steppe	Grasslands in forest zone	Forests	Juniper	Broadleaf woodland	Semidesert	Desert	Marsh	Average
Aragatsotn	-0.02	-0.02	-0.02	-0.04	-0.03	0.55			-0.04		-0.05	-0.02
Ararat	-0.02	-0.02	-0.02	-0.05	-0.03	0.51		-0.02	-0.03	-0.02	-0.02	-0.03
Armavir						0.16			-0.02		-0.02	-0.02
Gegharkunik	-0.02	-0.02	-0.01	-0.03	-0.02	0.56	-0.02	-0.05			-0.03	0.00
Kotayk	-0.02	-0.02	-0.02	-0.04	-0.02	0.56		-0.04	-0.05		-0.05	0.03
Lori	-0.02	-0.01	0.01	0.00	0.08	0.62		0.15			0.02	0.17
Shirak	-0.02	-0.02	-0.02	-0.04		0.57			-0.06		-0.03	-0.03
Syunik	-0.02	-0.02	-0.02	-0.03	0.04	0.54	0.03	0.01	-0.01		-0.04	0.07
Tavush	-0.02	0.02		0.00	0.08	0.64		0.04				0.35
Vayots Dzor	-0.02	-0.03	-0.02	-0.04	-0.03	0.47	-0.05	-0.04	-0.05		-0.02	-0.03
Average	-0.02	-0.02	-0.01	-0.04	0.03	0.60	-0.04	0.04	-0.04	-0.02	-0.02	

749

750 **3.1.E3. Potential ES changes from 2017 to 2023**

751 **Assessment of ES changes based on the 2017 and 2023 modelled ES maps**

752 From 2017 to 2023, there were slight changes in CC oppositely directed in different locations (Figure 3.1.E3-1).
 753 Significant decrease in CC occurred in the Syunik due to replacement of some forests with grasslands, as well in the Ararat
 754 due to replacement of some croplands with grasslands and built-up areas. Increase in CC occurred in the Shirak and the
 755 Lori due to replacement of some grasslands with croplands (Figure 3.1.E3-2; for changes in land cover see Section 2.2).
 756 Changes in CC in settlements range from a decrease of 61% to an increase of 65% (Appendix 3.1.E-3).
 757

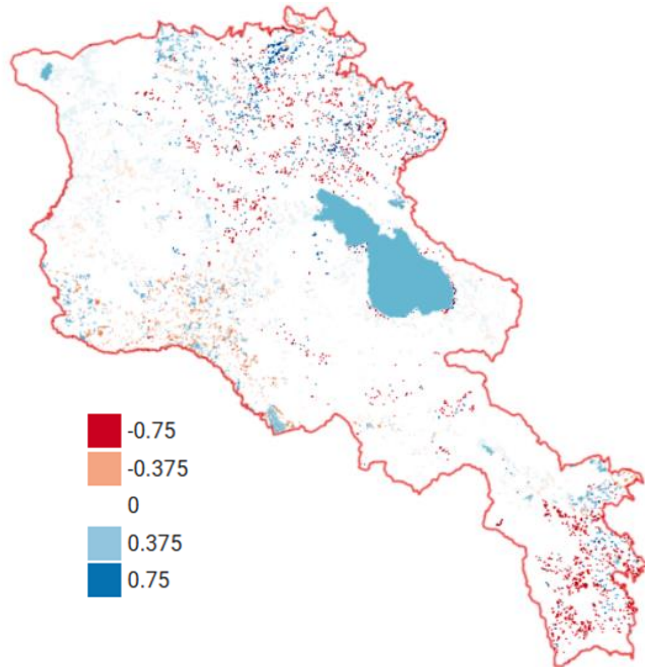

758
 759 *Figure 3.1.E3-1. Changes in CC from 2017 to 2023. For details see project Web GIS <https://bccarmenia.nextgis.com/>,*
 760 *section "Ecosystem services. Urban Cooling"*

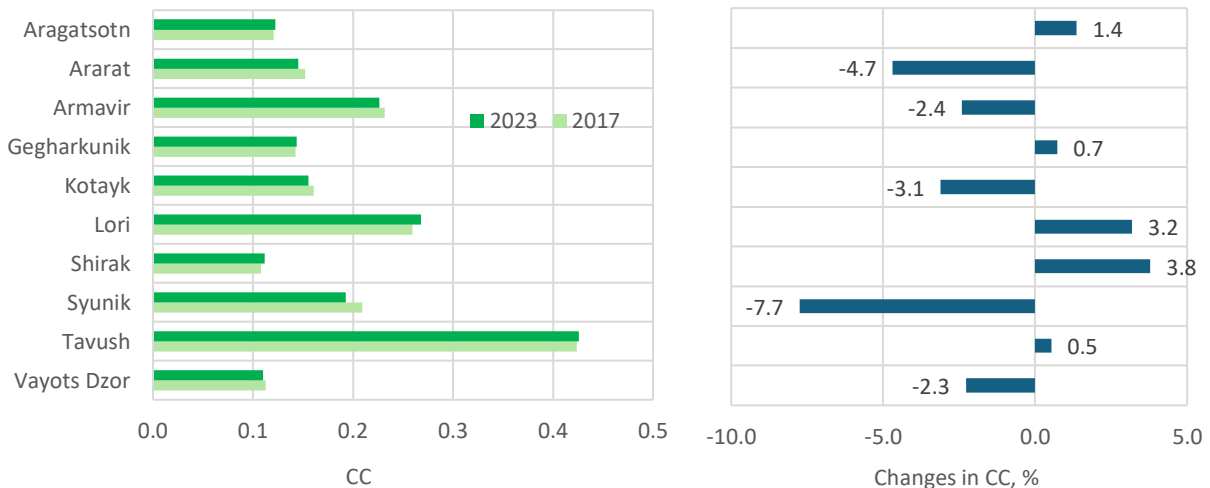

761
 762 *Figure 3.1.E3-3. Changes in CC from 2017 to 2023 across marzes*

763

764

3.1.G. Carbon storage in soil and tree biomass

765

766

767

768

769

770

771

The assessment of soil carbon stocks at 0-30 cm depth was made using data from the World Soils 250m Organic Carbon Stocks dataset (<https://www.arcgis.com/home/item.html?id=496c19426413472194b10b2b0952fccd#>) (Figure 3.1.G-1). Carbon stock in tree biomass was estimated using the area of tree cover from Esri (2023) and the average carbon content of wood. According to the Acopian Center (AUA), a pilot study conducted in forests near the town of Vanadzor (northeastern Armenia) revealed a value of 98 tC/ha. However, data from [State of the World’s Forests \(FAO, 2011\)](#) estimate the total carbon stock in living forest biomass in Armenia at 13 million tons, with an average of 48 tC/ha across the country. We used 48 tC/ha average in our calculations.

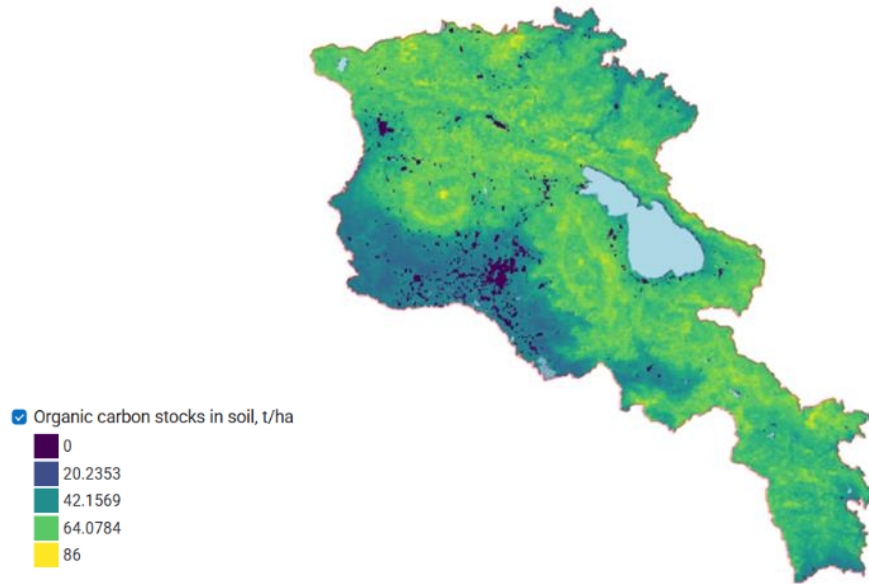

772

773

774

Figure 3.1.G-1. Soil carbon stocks, t/ha; For details see project Web GIS <https://bccarmenia.nextgis.com/>, section "Ecosystem services. Carbon storage"

775

3.1.G1. Carbon stocks in Armenia, marzes and vegetation zones

776

777

778

779

780

781

Total carbon stock in 0-30 cm depth soils in Armenia within natural areas (excluding croplands and built-up areas) amounts to 135.7 MtC, and in tree biomass 15.1 MtC (in 2023) that totally amounts to 150.9 MtC. Due to the relatively small forest area in Armenia, the main carbon stock (90%) is stored in soils. The average carbon content in the 30-cm soil layer across vegetation types ranges from 30 t/ha in desert to 64 t/ha in mountain grasslands. Average C-content in most of the marzes varies around 60 tC/ha. In Armavir and Ararat, it is lower (33 and 48 t/ha, respectively) due to the carbon-poor semi-desert soils (Figure 3.1.G1-1; Table 3.1.G1-1).

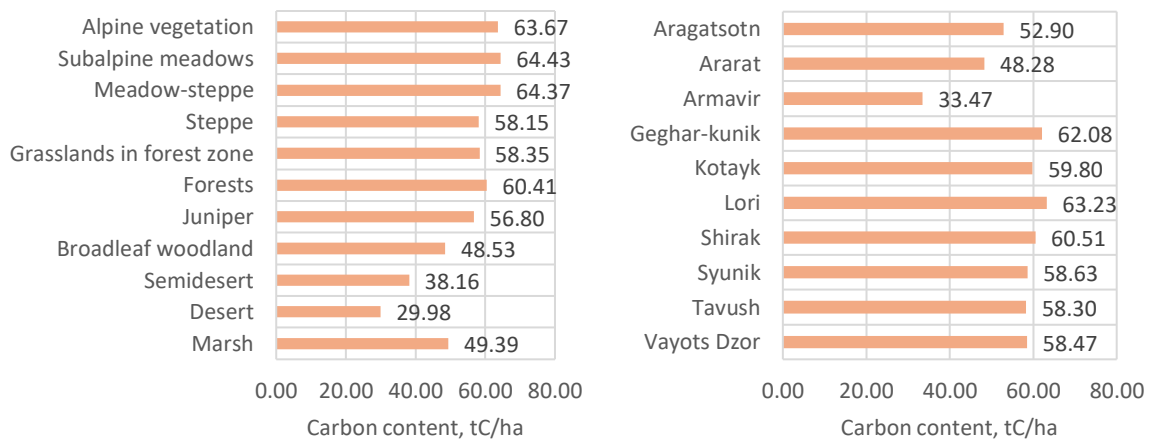

782

783

784

Figure 3.1.G1-1. Carbon content in soil, tC/ha, across vegetation types (a) and marzes (b). Area of the marz Gegharkunik is accounted excluding Lake Sevan

785 The total carbon stock is highest in marzes Syunik and Lori (24 and 21 MtC), and lowest in marz Armavir (1.5 MtC)
 786 because of low carbon content in soil and small area of ecosystems (Figure 3.1.G1-2; Table 3.1.G1-1). The carbon stock
 787 in tree biomass makes a noticeable addition to soil carbon only in marzes Tavush and Lori. Across vegetation types total
 788 carbon stock is highest in forests with a large portion of C in wood, followed steppe and subalpine zones. C stock is lowest
 789 in woodlands, marshes and deserts due to their limited extent (Figure 3.1.G1-3).

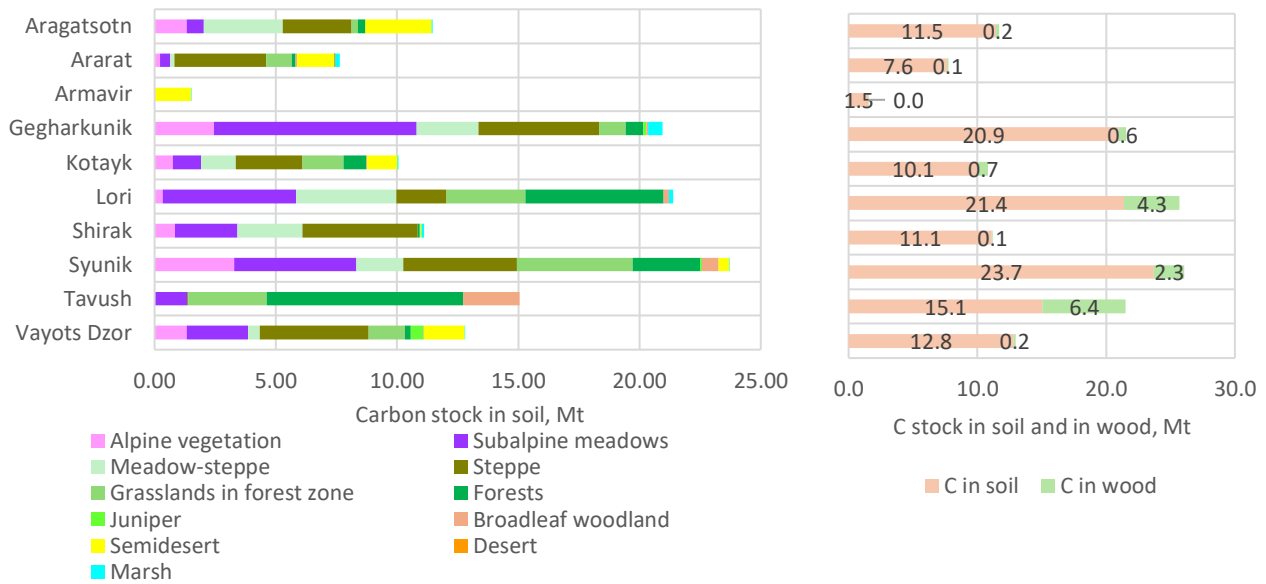

790
 791 *Figure 3.1.G1-2. Carbon stock, MtC in soil in different vegetation types across marzes (a) total C stock in soil and wood*
 792 *across marzes (b). Area of the marz Gegharkunik is accounted excluding Lake Sevan*

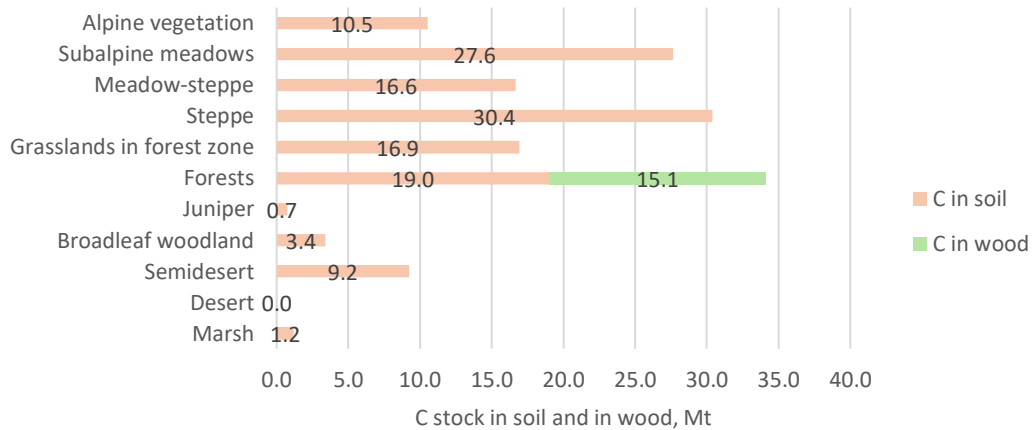

793
 794 *Figure 3.1.G1-3. Carbon stock, MtC, across vegetation types*

795 *Table 3.1.G1-1. Carbon content and carbon stocks in soil across different vegetation types and marzes*

		Alpine vegetation	Subalpine meadows	Meadow-steppe	Steppe	Grasslands in forest zone	Forests	Juniper	Broadleaf woodland	Semidesert	Desert	Marsh	Average
Carbon content, t/ha	Aragatsotn	65.18	66.04	64.39	54.84	62.07	62.85			36.76		51.85	52.90
	Ararat	62.53	63.93	63.08	51.47	60.18	61.52		63.02	34.71	29.98	37.50	48.28
	Armavir						37.79			33.41		35.38	33.47
	Gegharkunik	62.84	65.18	63.70	61.03	48.58	55.87	65.33	55.00			64.41	62.08
	Kotayk	65.40	66.39	64.45	61.00	62.19	61.76		64.33	45.17		58.24	59.80
	Lori	72.37	64.93	63.69	61.18	62.13	63.24		51.23			58.33	63.23
	Shirak	65.84	63.68	64.64	57.76		62.43			38.69		40.02	60.51
	Syunik	62.51	62.07	66.30	59.99	54.87	57.08	54.52	46.49	40.84		20.22	58.63
	Tavush	72.52	64.03		65.37	60.70	60.19		48.35				58.30
	Vayots Dzor	62.87	65.54	64.16	58.69	60.67	64.26	55.29	54.74	45.70		33.45	58.47
	Average	63.67	64.43	64.37	58.15	58.35	60.41	56.80	48.53	38.16	29.98	49.39	

		Alpine vegetation	Subalpine meadows	Meadow-steppe	Steppe	Grasslands in forest zone	Forests	Juniper	Broadleaf woodland	Semidesert	Desert	Marsh	Total
Carbon stock, Mt	Aragatsotn	1.33	0.71	3.24	2.84	0.27	0.31	0.00	0.00	2.74	0.00	0.03	11.46
	Ararat	0.23	0.40	0.19	3.77	1.06	0.16	0.00	0.06	1.54	0.02	0.19	7.63
	Armavir	0.00	0.00	0.00	0.00	0.00	0.00	0.00	0.00	1.50	0.00	0.02	1.53
	Gegharkunik	2.45	8.35	2.55	4.99	1.10	0.71	0.14	0.06	0.00	0.00	0.60	20.95
	Kotayk	0.74	1.17	1.43	2.75	1.70	0.96	0.00	0.01	1.26	0.00	0.05	10.07
	Lori	0.33	5.51	4.14	2.06	3.27	5.69	0.00	0.21	0.00	0.00	0.18	21.39
	Shirak	0.84	2.57	2.67	4.76	0.00	0.09	0.00	0.00	0.07	0.00	0.12	11.12
	Syunik	3.28	5.05	1.93	4.69	4.78	2.78	0.07	0.68	0.45	0.00	0.01	23.72
	Tavush	0.00	1.35	0.00	0.04	3.24	8.09	0.00	2.34	0.00	0.00	0.00	15.06
Vayots Dzor	1.32	2.52	0.50	4.48	1.49	0.24	0.53	0.03	1.67	0.00	0.00	12.79	
	Total	10.54	27.63	16.65	30.39	16.91	19.03	0.74	3.38	9.23	0.02	1.20	135.71

796

797

3.1.G2.Changes in carbon stock in tree biomass from 2017 to 2023

798

799 Changes in carbon stock in natural areas of different vegetation types were assessed on the basis of changes in area
800 of vegetation types from accounting table for ecosystem extent (Table 2.3.C-2) using the indicator of carbon content per
801 ha across different vegetation types in 2023 (Table 3.1.G1-1). In this calculation, we did not take into account the changes
802 in per-hectare ES potential values between 2017 and 2023. This approach makes it possible to calculate the data for the
803 table recording the dynamics of the ES potential/capacity (Table 3.1.G2-1).

804

805 It's important to remember that this analysis doesn't show a reduction in soil carbon content. We don't know how
806 soil carbon content changes in areas converted from nature to agriculture or development and vice versa. This analysis
807 only shows how carbon stocks in natural areas change due to changes in their area.

808

809 Totally, C stocks in natural areas decreased by 4.26 Mt, that is by 2.7% of 2017 stocks. The most significant decreases
810 occurred in steppe and meadow-steppe zones, as well as in forests, including reductions in C stocks in soils and wood.
811 Stocks in grasslands in the forest zone increased slightly due to an increase in their area (Table 3.1.G2-1; Figure 3.1.G2-1).

Table 3.1.G2-1. Accounting table for the changes in ES potential, Mt

	Alpine vegetation	Subalpine meadows	Meadow-steppe	Steppe	Grassl. in forest zone	Forests		Juniper	Broadleaf woodland	Semi-desert	Desert	Marsh	Total
						C in soil	C in wood						
Opening ES capacity in 2017	10.48	27.71	18.29	31.65	16.63	19.81	15.74	0.73	3.45	9.46	0.02	1.17	155.14
Additions to ES capacity	0.03	0.50	0.23	1.12	1.57	1.39	1.11	0.01	0.28	0.74	0.00	0.09	7.06
Managed/unmanaged	NA												
Reductions ES capacity	0.02	0.54	1.86	2.35	1.30	2.23	1.78	0.01	0.34	0.78	0.00	0.12	11.32
Managed/unmanaged	NA												
Net change ES capacity	0.01	-0.04	-1.64	-1.22	0.27	-0.84	-0.67	0.01	-0.06	-0.04	0.00	-0.03	-4.26
Closing ES capacity in 2023	10.49	27.66	16.65	30.43	16.90	18.97	15.08	0.74	3.39	9.42	0.02	1.14	150.88

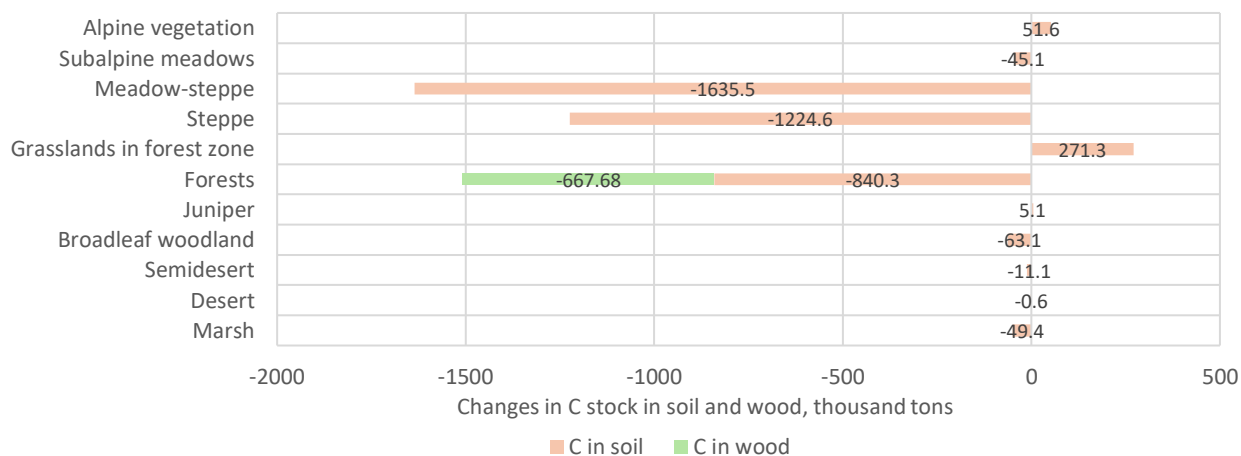
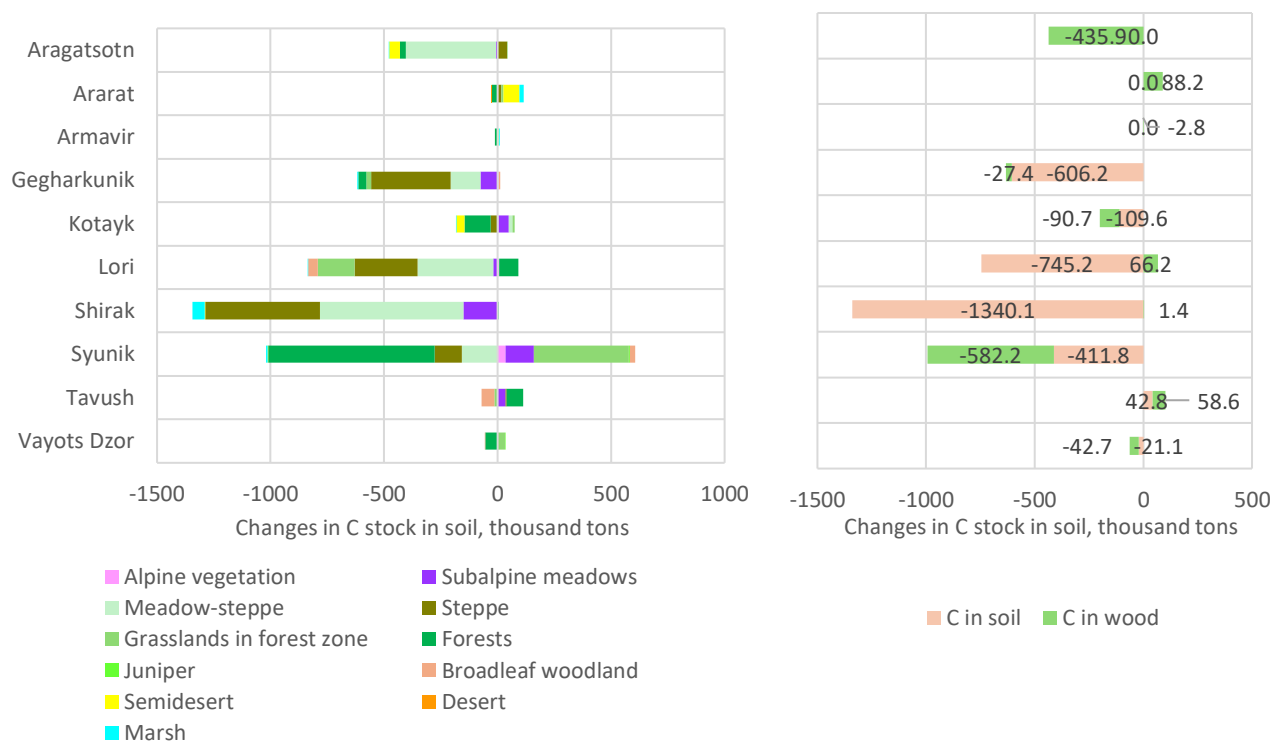

Figure 3.1.G2-1. Changes in carbon stock across vegetation types

810

811

812 At the marz level, carbon stocks declined primarily. Declines in the marzs of Shirak, Lori, Gegharkunik, and Aragatsotn
 813 were due to a reduction in grassland area and, consequently, a reduction in soil carbon stocks. In Syunik marz, stocks
 814 declined in both soil and timber due to a reduction in forest area, which failed to offset the increase in grassland area
 815 (Figure 3.1.G2-2).



816

817

818

819

Figure 3.1.G2-2. Changes in carbon stocks across marzes

Table 3.1.G2-2. Changes in C stock in soils in different vegetation types across marzes, thousand tons

	C stock in soil												C stock in wood	Total
	Alpine vegetation	Subalpine meadows	Meadow-steppe	Steppe	Grasslands in forest zone	Forests	Juniper	Broadleaf woodland	Semidesert	Desert	Marsh	Total		
Aragatsotn	0.6	-7.1	-397.1	41.3	2.3	-25.4	0.0	0.0	-48.1	0.0	-2.5	-435.9	-20.16	-456.0
Ararat	-0.6	1.9	0.0	14.5	8.2	-26.0	0.0	0.0	72.5	-0.6	18.3	88.2	-20.64	67.6
Armavir	0.0	0.0	0.0	0.0	0.0	-12.7	0.0	0.0	3.4	0.0	6.4	-2.8	-10.08	-12.9
Gegharkunik	3.8	-76.0	-130.0	-350.1	-22.8	-34.4	0.0	8.7	0.0	0.0	-5.4	-606.2	-27.36	-633.5
Kotayk	3.8	45.7	16.1	-30.8	8.8	-114.2	0.0	0.0	-37.0	0.0	-2.0	-109.6	-90.72	-200.3
Lori	7.0	-20.0	-332.1	-277.9	-162.8	83.4	0.0	-40.8	0.0	0.0	-2.0	-745.2	66.24	-679.0
Shirak	2.5	-149.5	-634.0	-505.3	0.0	1.8	0.0	0.0	-0.4	0.0	-55.3	-1340.1	1.44	-1338.7
Syunik	34.4	124.3	-158.3	-119.2	419.5	-732.8	4.0	24.7	-1.5	0.0	-6.9	-411.8	-582.24	-994.0
Tavush	0.0	36.1	0.0	3.5	-15.2	73.7	0.0	-55.3	0.0	0.0	0.0	42.8	58.56	101.3
Vayots Dzor	0.0	-0.6	0.0	-0.6	33.3	-53.8	1.1	-0.5	0.0	0.0	0.0	-21.1	-42.72	-63.8
Total	51.6	-45.1	-1635.5	-1224.6	271.3	-840.3	5.1	-63.1	-11.1	-0.6	-49.4	-3541.7	-667.7	-4209.3

820

821

3.1.H. Pollination

822 The assessment of the ecosystem service of crop pollination by wild pollinators comprises the following components:

- 823 • identification of the taxonomic composition and relative abundance of key pollinator groups across habitat
- 824 types, based on the terrestrial ecosystem map developed within the project;
- 825 • assessment of the contribution of different terrestrial ecosystem types to the provision of pollination services
- 826 at the national level;
- 827 • spatial modelling and mapping of pollination service potential using GIS for four main pollinator groups
- 828 (Hymenoptera, Lepidoptera, Diptera, Coleoptera);
- 829 • estimation of service use based on statistical data from Armstat on the area of pollinator-dependent crops at
- 830 the marz level.

831 Habitat maps for wild pollinators were derived from the vegetation map developed within the project (Section 2.3),
 832 combined with cropland, built-up, and tree cover classes from available land cover datasets. Tree cover within different
 833 vegetation zones was treated as a distinct habitat type.

834 For methodological purposes, the ecosystem service assessment was carried out using two alternative habitat maps
 835 based on the ESA 2021 and Esri 2023 land cover datasets (Figures 3.1.H-1 and 3.1.H-2; Appendix 3.1.H-1), which differ
 836 substantially in their level of detail.

3.1.H1. General description of the ecosystem service of pollination and key pollinator groups in Armenia

838 Pollination is a key ecosystem process supporting ecosystem stability and agricultural production. The role of
 839 pollinators is critical for maintaining plant community structure and function, as generative reproduction in most plant
 840 species depends on pollination. For the majority of wild and cultivated flowering plants, pollination occurs through
 841 allogamy (cross-pollination), primarily mediated by animals. Among animal pollinators, insects represent the dominant
 842 group. Feeding on floral resources has shaped key evolutionary traits of these groups, as well as the co-evolution of
 843 flowering plants. Long-term interactions between pollinators and flowering plants contribute to ecosystem resilience and
 844 stability. In mountainous countries such as Armenia, these interactions also support the formation of autochthonous and
 845 refugial micro-communities.

846 Across the territory of Armenia, pollinators are primarily represented by four insect orders: *Hymenoptera*,
 847 *Lepidoptera*, *Diptera*, and *Coleoptera*. *Hymenoptera* constitute the dominant group in terms of pollination service supply.
 848 Within this order, the superfamily *Apoidea* (bees) plays a central role, including key functional groups such as bees,
 849 bumblebees, and carpenter bees. Representatives of *Apoidea* act as primary pollinators across most ecosystem types
 850 and plant communities, including major plant families such as *Fabaceae*, *Apiaceae*, *Asteraceae*, *Rosaceae*, *Liliaceae*,
 851 *Lamiaceae*, *Amaranthaceae*, and *Cucurbitaceae*. Bees are the main providers of pollination services for agricultural crops.
 852 Wild bees complement pollination service supply where managed honey bees are insufficient, due to their relatively large
 853 foraging ranges and high ecological adaptability, particularly under mountainous conditions. Among wild bees,
 854 bumblebees (*Bombinae*) and carpenter bees (*Xylocopa*) play a particularly important role in service provision.

855 *Lepidoptera* contribute to pollination primarily through *Microlepidoptera*, a group of small, mostly nocturnal and
 856 crepuscular species that act as key pollinators of small-flowered plants during nighttime. In addition, members of
 857 *Macroheterocera* (including *Noctuoidea*) provide important pollination services in petrophilous and alpine ecosystems.
 858 In contrast, diurnal butterflies (*Rhopalocera*) play a comparatively minor role in pollination.

859 *Diptera* represent the third most important group in terms of pollination service supply. Within this order, key
 860 pollinators belong to the infraorder *Cyclorrhapha*, including *Syrphidae*, *Bombyliidae*, *Tachinidae*, and *Muscidae*. Although
 861 many dipteran species frequently visit flowers, their overall contribution to pollination is lower compared to
 862 *Hymenoptera* and *Lepidoptera*, partly due to lower body hair density. Nevertheless, *Diptera* are important pollinators for
 863 several plant groups, including *Apiaceae*, *Araceae*, *Apocynaceae*, *Orobanchaceae*, *Caprifoliaceae*, as well as some
 864 *Fagaceae*, *Solanaceae*, and *Rosaceae*. In forest and wetland ecosystems, *Diptera* often act as primary pollinators.

865 *Coleoptera* represent the fourth group in terms of pollination service supply. Most melitophilous beetles are not
 866 primary pollinators, due to morphological characteristics, in particular relatively smooth body surfaces that limit pollen
 867 adhesion. However, under the conditions of Armenia, several genera contribute significantly to pollination, and in specific
 868 ecosystems and plant communities may act as primary pollinators. These include representatives of the genera *Eulasia*,
 869 *Pygopleurus*, *Hoplia*, as well as many members of the subfamily *Alleculinae* and the family *Meloidae*. Hairy scarab beetles
 870 of the genera *Eulasia* and *Pygopleurus* function as primary pollinators in ephemeral plant communities typical of semi-
 871 desert ecosystems, as well as in juniper open woodlands and mountain phrygana. In these ecosystems, they pollinate
 872 both ephemeral herbaceous plants and woody species, including *Crataegus*, *Rosa*, and *Amygdalus*, as well as xerophytic
 873 and mesophytic *Asteraceae* communities. Species of the genus *Hoplia* and many *Alleculinae*, associated with forest and

874 broadleaf woodland ecosystems, act as early visitors of flowering trees. Members of the family *Meloidae* function as
 875 primary or secondary pollinators of characteristic steppe tall-herb vegetation.
 876

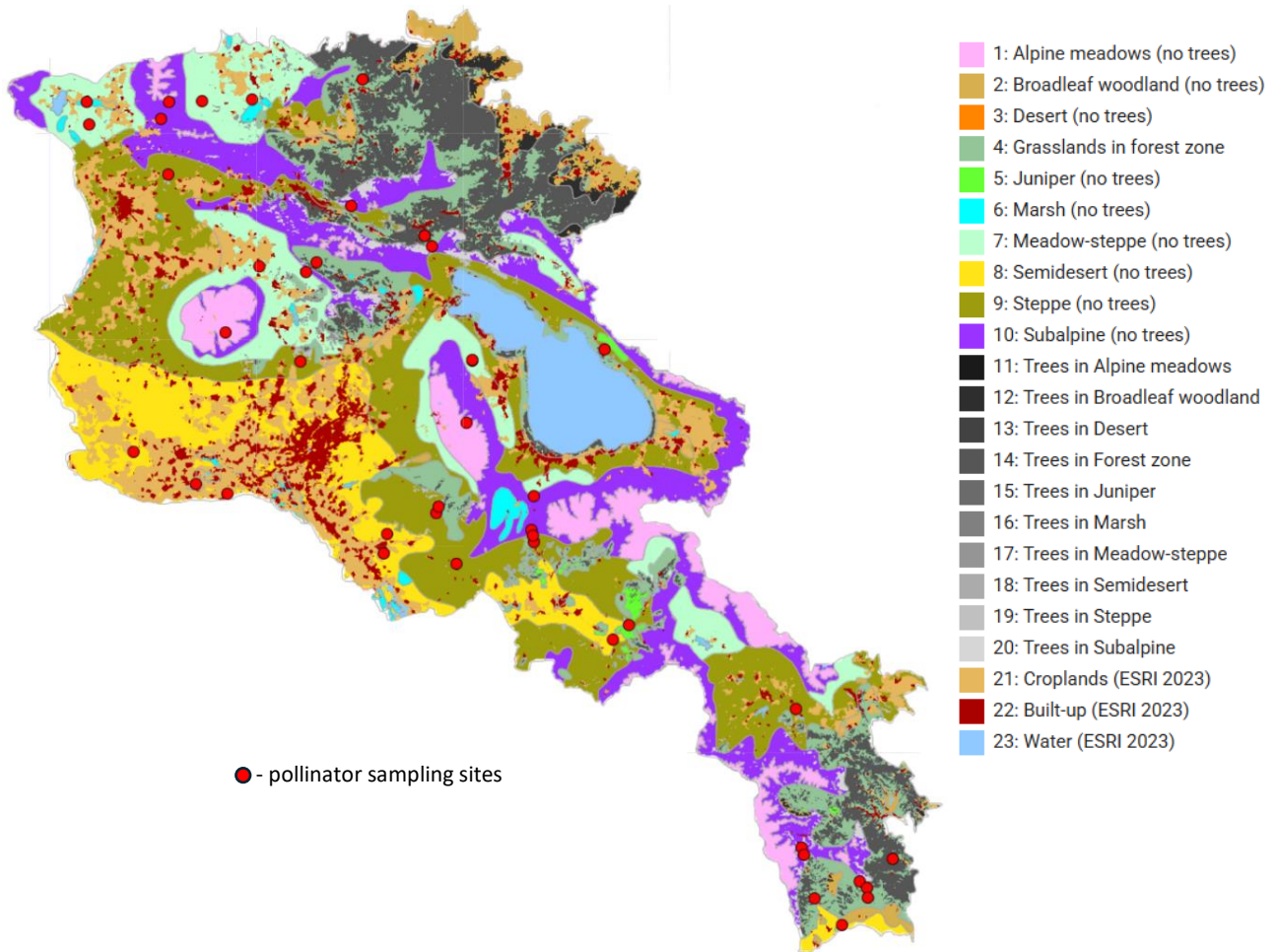

877

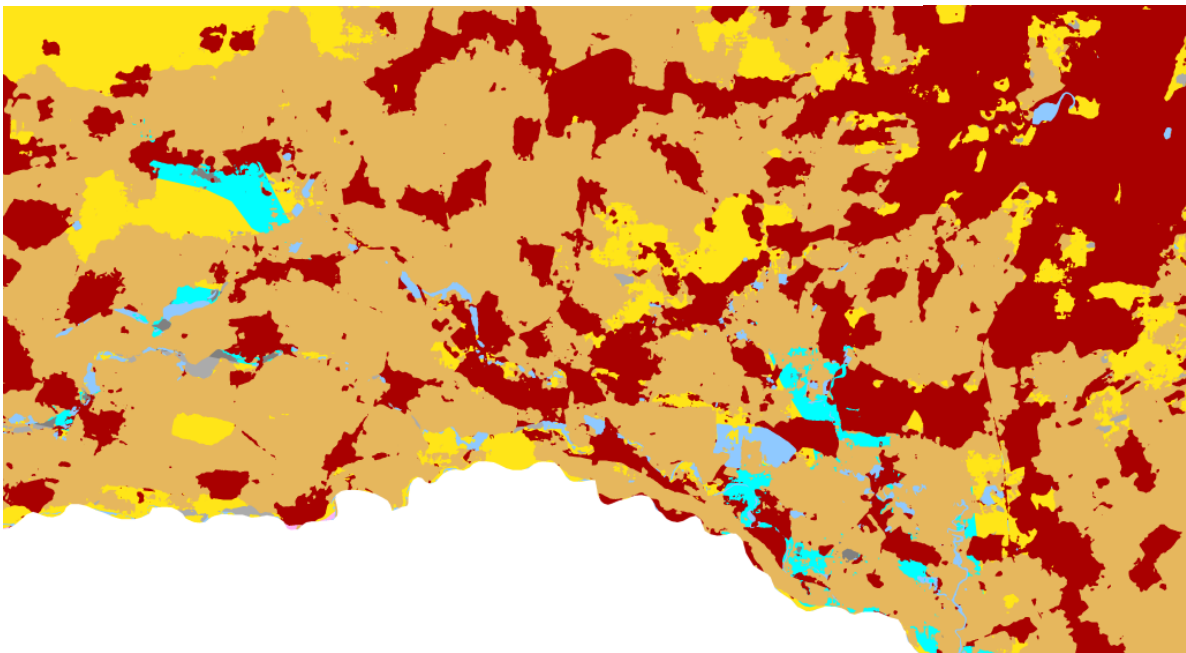

878

879 Figure 3.1.H-1. Map of pollinator habitats based on the Esri 2023 land cover dataset. An enlarged fragment of the
 880 Ararat Valley is shown at the bottom. For details see project Web GIS <https://bccarmenia.nextgis.com/>, section
 881 "Ecosystem services. Pollination"

882

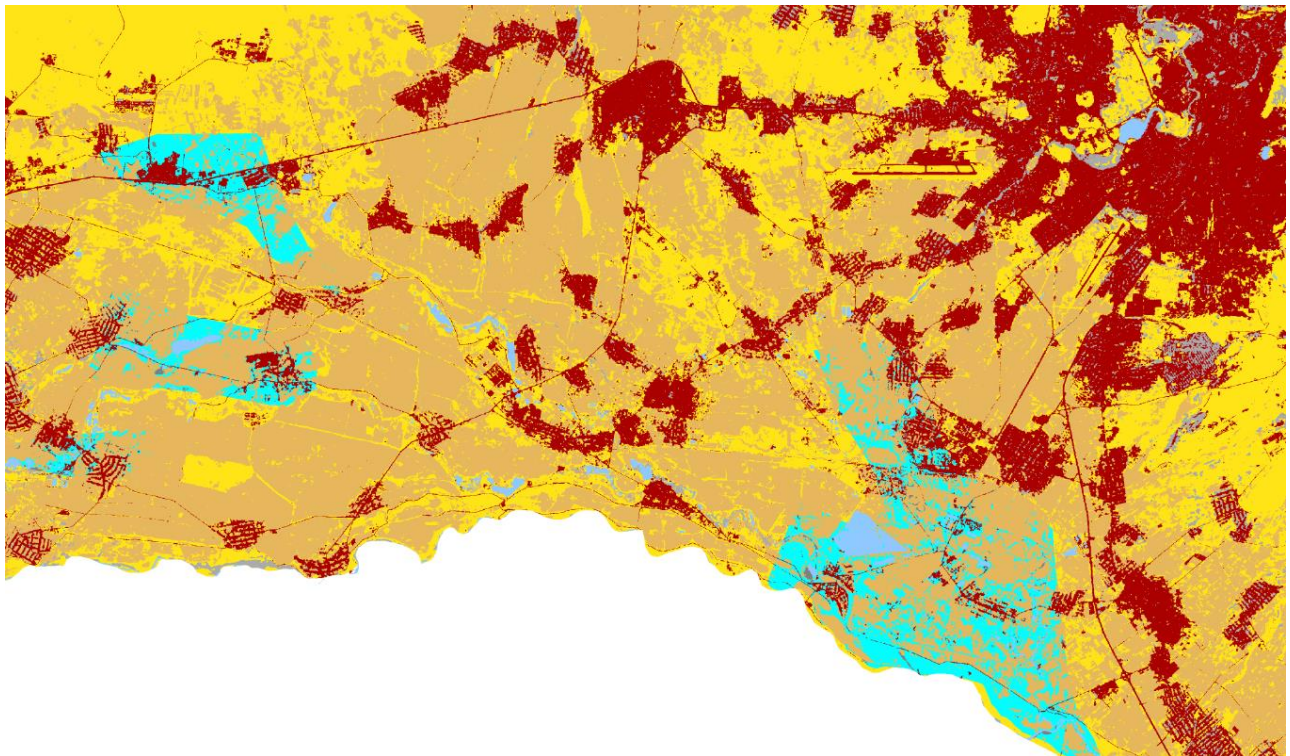
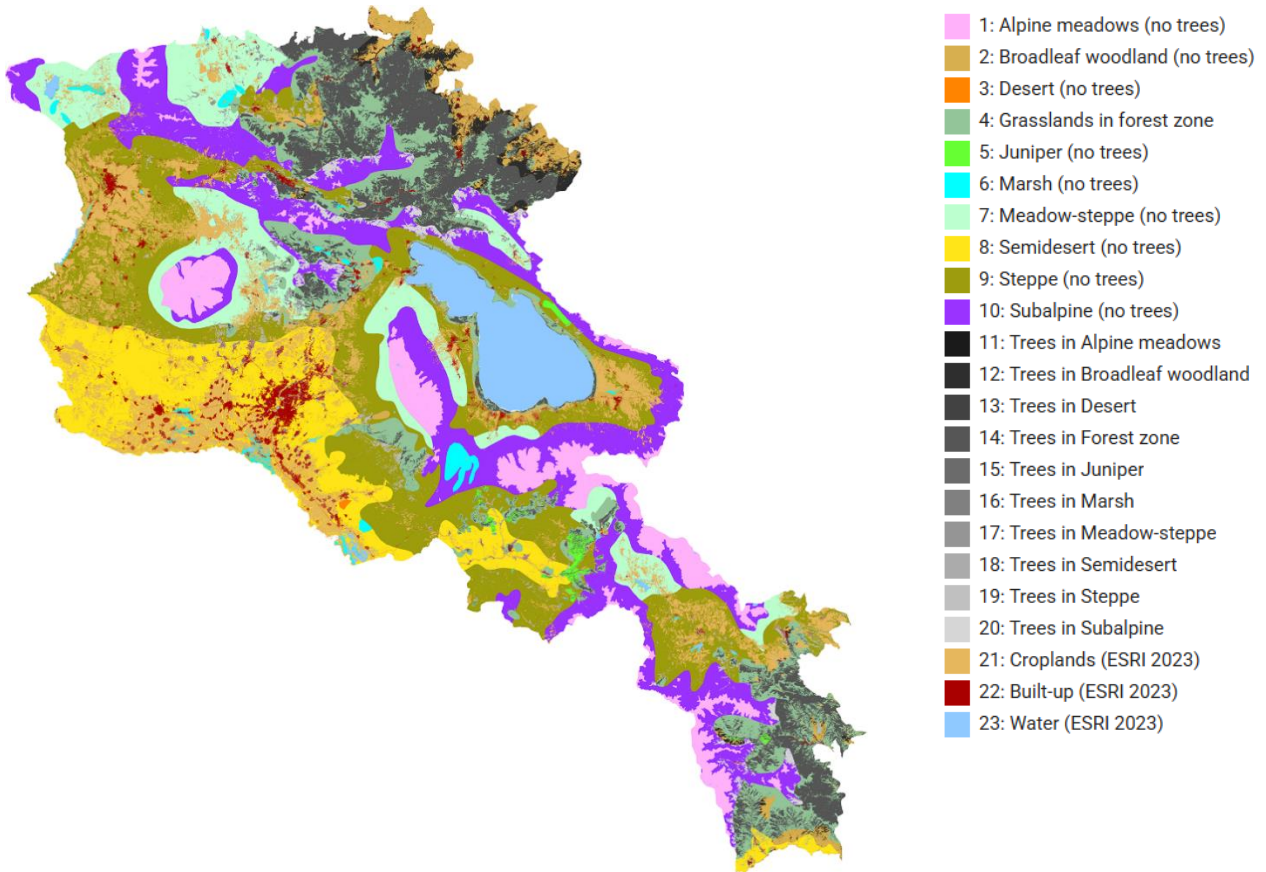

883

884

885

886

Figure 3.1.H-2. Map of pollinator habitats based on the ESA 2021 land cover dataset. An enlarged fragment of the Ararat Valley is shown at the bottom. For details see project Web GIS <https://bccarmenia.nextgis.com/>, section "Ecosystem services. Pollination"

887 Field surveys were conducted across all marzes of Armenia from the second ten-day period of May to the first ten-
 888 day period of September 2025, at elevations ranging from 900 to 2900 m a.s.l., covering all major ecosystem types and
 889 habitats (Figure 3.1.H-1, Appendix 3.1.H-2). In some cases (e.g. Mount Aragats), survey locations had to be adjusted due
 890 to significant or complete degradation of habitats, resulting from overgrazing by small livestock, soil degradation, and
 891 fires.

892 Pollinator surveys were conducted using a transect-based sampling method (transect length: 300 m; width: 2 m). Each
 893 transect was surveyed three times over a 3-hour period during daytime (10:00–16:00, under clear weather conditions)
 894 and once during nighttime (approximately 1 hour per survey). Pollinators were collected during transect walks using
 895 sweep netting. Transect locations were selected based on the abundance and diversity of flowering plants. Prior to
 896 pollinator sampling, a preliminary plant survey was conducted at each transect to characterize the plant community and
 897 associated habitat. Plant species were identified using field identification guides and the multi-volume reference Flora of
 898 Armenia. Habitat types were identified in accordance with the classification presented in Habitats of Armenia (Fayvush,
 899 Aleksanyan, 2016). Collected specimens were temporarily immobilized using CO₂, counted, and identified to genus level
 900 (and in some cases to species level). A portion of the specimens was subsequently released back into the environment.
 901 Pollinator abundance was assessed through direct observation and counting. Nighttime observations were conducted
 902 using UV light sources. Abundance was recorded using a semi-quantitative scoring system ranging from 0 to 5, defined
 903 as follows: 0 - up to 2 individuals per insect order; 1 - up to 6 individuals; 2 - up to 13 individuals; 3 - up to 18 individuals;
 904 4 - up to 24 individuals; 5 - up to 32 or more individuals.

905 The assessment identified the species composition of key pollinators across all four insect orders. Appendix 3.1.H-3
 906 provides a list of pollinator species that were consistently observed during the surveys. In total, *Hymenoptera (Apoidea)*
 907 were represented by 24 species, *Lepidoptera* by 22 species, *Diptera (Cyclorrhapha)* by 21 species, and *Coleoptera* by 21
 908 species. The presented list is not exhaustive; however, the recorded taxa represent the main pollinator groups occurring
 909 in natural ecosystems of Armenia and contributing to ecosystem service supply. The highest pollinator species richness
 910 was observed in steppe ecosystems (57 species), while the lowest richness was recorded in desert and semi-desert
 911 ecosystems (19 and 20 species, respectively) (Table 3.1.H-1, Figure 3.1.H-3).

912 Table 3.1.H-1. Species richness of four main pollinator groups across vegetation zones

	<i>Hymenoptera (Apoidea)</i>	<i>Lepidoptera</i>	<i>Diptera</i>	<i>Coleoptera</i>	Total species number
Alpine vegetation	7	8	8	2	25
Subalpine meadows	9	12	12	3	36
Meadow-steppe	13	16	14	8	51
Steppe	15	12	16	14	57
Forest zone	10	13	14	8	45
Juniper	9	6	6	10	31
Broadleaf woodland	11	10	5	7	33
Semi-desert	6	2	2	10	20
Desert	7	3	2	7	19
Marsh	6	6	10	2	24
Total species number*	24	22	21	21	

913 * This total is not equal to the sum of the species numbers reported for individual vegetation zones, since some species are present in
 914 multiple zones.
 915

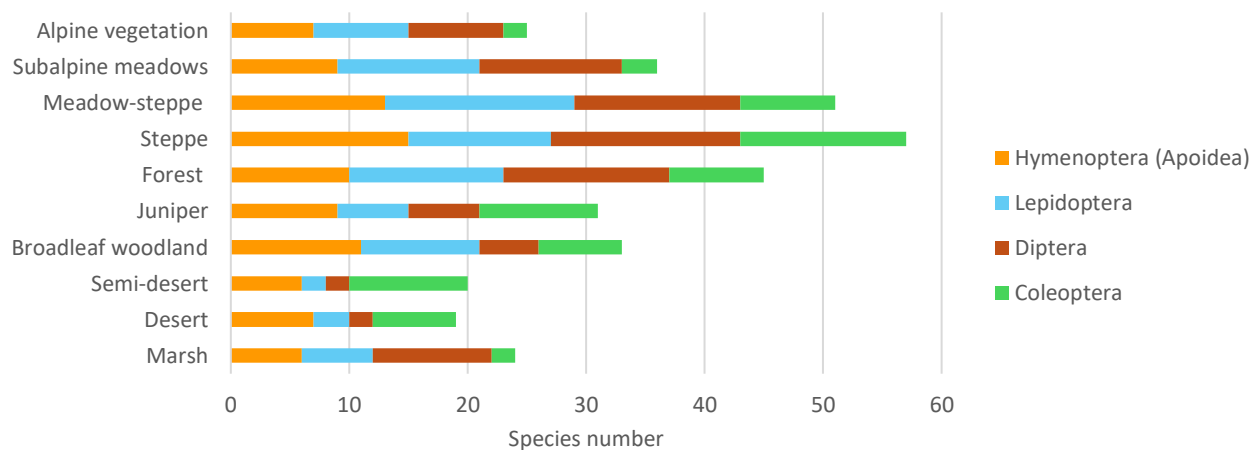

916 Figure 3.1.H-3. Species richness of four main pollinator groups across vegetation zones
 917

918 Pollinator abundance for each habitat type was assessed using a semi-quantitative scoring system (Table 3.1.H-2).
 919 These estimates are indicative and represent averaged values, as robust assessment of pollinator abundance would
 920 require multi-year monitoring (at least two years) and the application of a broader range of field sampling methods.
 921 Abundance scores were derived by averaging values across pollinator groups within each vegetation type and habitat.

922 Table 3.1.H-2. Pollinator abundance scores for four main groups across vegetation zones

	<i>Hymenoptera (Apoidea)</i>		<i>Lepidoptera</i>		<i>Diptera</i>		<i>Coleoptera</i>		<i>All pollinators</i>	
	Woody	Non-woody	Woody	Non-woody	Woody	Non-woody	Woody	Non-woody	Woody	Non-woody
Alpine vegetation	-	5	-	4	-	4	-	1	0	4
Subalpine meadows	-	5	1	3	-	5	-	1	0	4
Meadow-steppe	5	5	2	4	2	4	-	3	3	5
Steppe	3	5	2	4	5	5	-	3	3	5
Forest	2	4	5	3	1	4	3	3	5	4
Juniper	2	5	1	3	3	5	2	5	2	5
Broadleaf woodland	4	5	2	4	4	5	3	4	4	5
Semidesert	3	5	1	3	1	3	3	4	2	5
Desert	3	5	1	4	1	2	5	5	1	5
Marsh	2	2	4	1	5	5	-	1	1	3

923
 924 Assessment of the ES of crop pollination requires consideration of pollinator foraging ranges and their capacity to
 925 reach agricultural areas. Among the studied groups, *Hymenoptera (Apoidea)*, *Lepidoptera*, and *Diptera* exhibit the highest
 926 mobility and thus contribute most significantly to service flow from natural ecosystems to croplands. For *Apoidea*, typical
 927 foraging distances during active periods are up to approximately 2 km for larger species and around 500 m for smaller
 928 species. *Lepidoptera* generally exhibit greater dispersal capacity: nocturnal groups (e.g. *Noctuoidea*) may travel distances
 929 of up to 10 km per night, while smaller moths (*Microlepidoptera*) may disperse over even greater distances under
 930 favorable wind conditions. *Diptera* are characterized by relatively high mobility and rapid flight, with typical movement
 931 ranges of up to approximately 2 km during daytime. However, many species exhibit territorial behavior, which limits long-
 932 distance movements under normal conditions.

933 Among all groups, *Apoidea* (bees), particularly bumblebees, account for the largest share of visits to agricultural lands.
 934 Field observations in the Ararat Valley, Gegharkunik, Shirak, and Vayots Dzor indicate that bumblebees and carpenter
 935 bees actively visit fields of sainfoin and alfalfa, as well as horticultural crops (tomato, pepper, and cucumber), particularly
 936 during hot daytime periods in June–July. Agricultural fields provide additional foraging resources and relatively
 937 постоянный доступ к воде; however, due to the lack of suitable nesting conditions, these habitats do not support stable
 938 pollinator populations. Several factors within agricultural systems adversely affect pollinators, including irrigation
 939 regimes, lack of shelter, competition with managed honey bees, and pesticide use. Under these conditions, the
 940 effective foraging range contributing to crop pollination is typically within approximately 0.3–1 km from natural or
 941 semi-natural habitats.

942 In contrast, *Lepidoptera* exhibit a different interaction with agricultural landscapes. In many species, larvae feed on
 943 the same or related plant species that are visited by adults for pollination, including a number of crops. In addition, the
 944 broad range of host plants results in the presence of stable populations associated with field margins and weedy
 945 vegetation. Periodically, adult butterflies and moths also contribute to pollination through movement between habitats,
 946 particularly during population outbreaks.

947 *Diptera* show a similar pattern, with the key difference that larval stages of many pollinating species develop in soils
 948 rich in decomposing organic matter. Constant moisture and accumulation of plant residues support stable populations
 949 of dipteran pollinators near agricultural fields. The use of compost as fertilizer further enhances these conditions and
 950 contributes to maintaining pollinator populations.

951 For the ES mapping, the following average pollinator foraging distances to agricultural fields were applied:
 952 *Hymenoptera* – 460 m, *Lepidoptera* – 260 m, *Diptera* – 260 m, and *Coleoptera* – 160 m.

953 At the current stage of ES assessment, seasonal variation in pollination was not accounted for. However, incorporation
 954 of seasonality is required in further refinement of the assessment. Seasonal activity patterns of the recorded pollinators
 955 were observed at monitoring sites throughout the flowering period of vegetation, from the second ten-day period of May
 956 to the first ten-day period of September (Figure 3.1.H-4). Pollinator activity is directly influenced by temperature and
 957 moisture conditions. Peak activity for all pollinator groups was observed during June–July. Seasonal activity patterns vary
 958 across elevation gradients, with different groups exhibiting peak activity at different times depending on altitude.

959 Weather conditions are key factor affecting pollinator activity. Rapid temperature fluctuations are a primary factor
 960 reducing activity. Under conditions of low temperatures and precipitation, *Apoidea* (particularly bumblebees) and *Diptera*

961 remain relatively active, while other groups show limited or negligible activity. *Lepidoptera* represent a partial exception,
 962 as many species remain active during nighttime even under relatively low temperatures and light precipitation (with the
 963 exception of *Rhopalocera*, which are not primary pollinators). In addition to low temperatures, extremely high
 964 temperatures also act as a negative factor. During periods of extreme heat, most pollinators exhibit reduced activity, with
 965 the exception of some *Diptera* and *Coleoptera*. High temperatures also contribute to increased predator activity, further
 966 affecting pollinator presence and behavior.

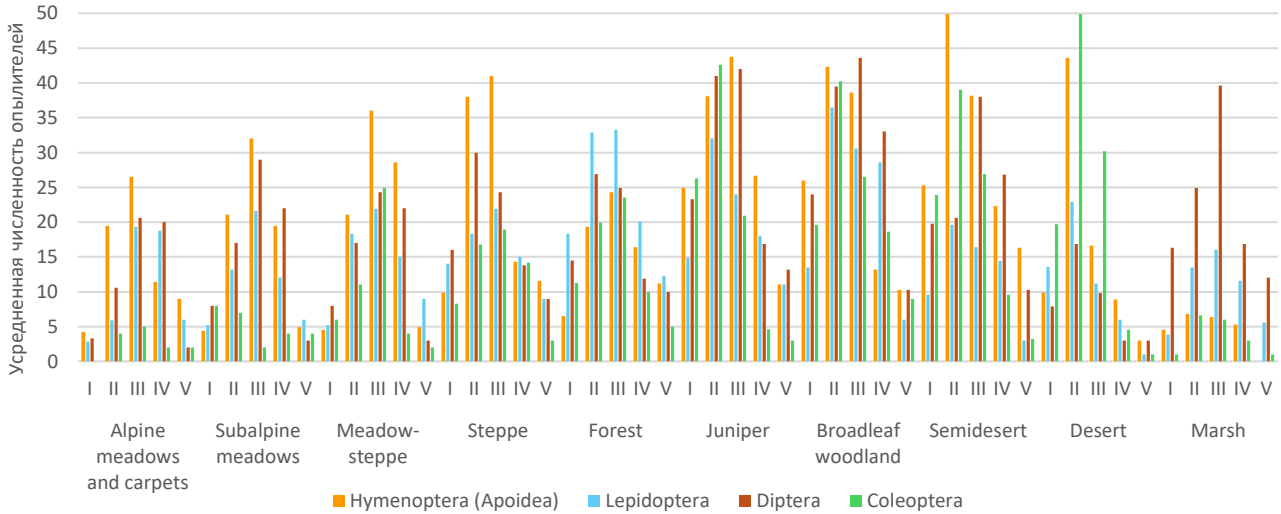

967
 968 *Figure 3.1.H-4. Seasonal activity of pollinators. Months are indicated using Roman numerals.*

969 **3.1.H2. ES assessment**

970 ***Assessment of the importance of different natural ecosystem types for crop pollination***

971 The importance of pollination ES provided by different natural ecosystem types is determined by pollinator
 972 abundance (Table 3.1.H-2) and the length of the boundary between ecosystems and agricultural fields (Table 3.1.H-3).
 973 The total boundary length is 22,394 km when using the Esri 2023 land cover dataset and 90,202 km when using the ESA
 974 2021 dataset, i.e. approximately four times greater. This difference is explained by higher boundary fragmentation, as
 975 well as the presence of small ecosystem patches within agricultural fields and, conversely, field patches within natural
 976 ecosystems. Overall, agricultural fields have the longest boundaries with steppe and semi-desert ecosystems. Boundaries
 977 with tree-dominated ecosystems account for the smallest share of the total boundary length. In relative terms, the Esri
 978 land cover dataset shows a substantially higher proportion of field boundaries adjacent to built-up areas and lower
 979 proportions adjacent to steppe and semi-desert ecosystems compared to the ESA dataset (Table 3.1.H-3, Figure 3.1.H-5a).

980 A normalized pollinator abundance index (scaled to 1) for each habitat type was multiplied by the proportion of the
 981 boundary length between agricultural fields and that habitat type, resulting in normalized indices of the relative
 982 importance of habitat types for crop pollination (Table 3.1.H-3). As shown in Figure 3.1.H-5, five types of non-woody
 983 vegetation make a substantial contribution to crop pollination at the national scale, namely those associated with steppe,
 984 semi-desert, meadow-steppe, forest zone, and broadleaf woodland ecosystems (Figure 3.1.H-5b).

985 *Table 3.1.H-3. Calculation of the importance index of ecosystem types for crop pollination*

Ecosystem type		Length of the boundary with croplands, km		Share of total boundary length, %		Normalized pollinator abundance index	Habitat importance index for crop pollination		Normalized habitat importance index	
		Esri	ESA	Esri	ESA		Esri	ESA	Esri	ESA
Non-woody vegetation	Alpine vegetation	112.21	4.42	0.50	0.00	0	0.000	0.000	0.000	0.000
	Subalpine meadows	881.08	2333.22	3.93	2.59	0	0.000	0.000	0.000	0.000
	Meadow-steppe	2916.88	11083.71	13.03	12.29	0.6	7.815	7.373	0.175	0.142
	Steppe	6730.55	33013.09	30.05	36.60	0.6	18.033	21.959	0.404	0.424
	Grasslands in forest zone	1233.64	4775.90	5.51	5.29	1	5.509	5.295	0.123	0.102
	Juniper	5.37	49.97	0.02	0.06	0.4	0.010	0.022	0.000	0.000
	Broadleaf woodland	927.89	4548.18	4.14	5.04	0.8	3.315	4.034	0.074	0.078
	Semidesert	4628.31	24119.64	20.67	26.74	0.4	8.267	10.696	0.185	0.207
	Desert	2.54	12.96	0.01	0.01	0.2	0.002	0.003	0.000	0.000
Marsh	390.80	2154.72	1.75	2.39	0.2	0.349	0.478	0.008	0.009	

Woody vegetation	Alpine vegetation	0.00	0.00	0.00	0.00	0.8	0.000	0.000	0.000	0.000
	Subalpine meadows	18.92	8.24	0.08	0.01	0.8	0.068	0.007	0.002	0.000
	Meadow-steppe	83.99	91.26	0.38	0.10	1	0.375	0.101	0.008	0.002
	Steppe	64.85	286.61	0.29	0.32	1	0.290	0.318	0.006	0.006
	Forests	104.74	147.88	0.47	0.16	0.8	0.374	0.131	0.008	0.003
	Juniper	0.00	0.69	0.00	0.00	1	0.000	0.001	0.000	0.000
	Broadleaf woodland	39.83	172.29	0.18	0.19	1	0.178	0.191	0.004	0.004
	Semidesert	18.30	1004.35	0.08	1.11	1	0.082	1.113	0.002	0.022
	Desert	0.00	0.00	0.00	0.00	1	0.000	0.000	0.000	0.000
	Marsh	2.27	62.98	0.01	0.07	0.6	0.006	0.042	0.000	0.001
Built-up	3966.71	6061.27	17.71	6.72	0	0	0	0	0	
Water	265.26	270.48	1.18	0.30	0	0	0	0	0	
Total	22394.12	90201.87	100.00	100.00						

986

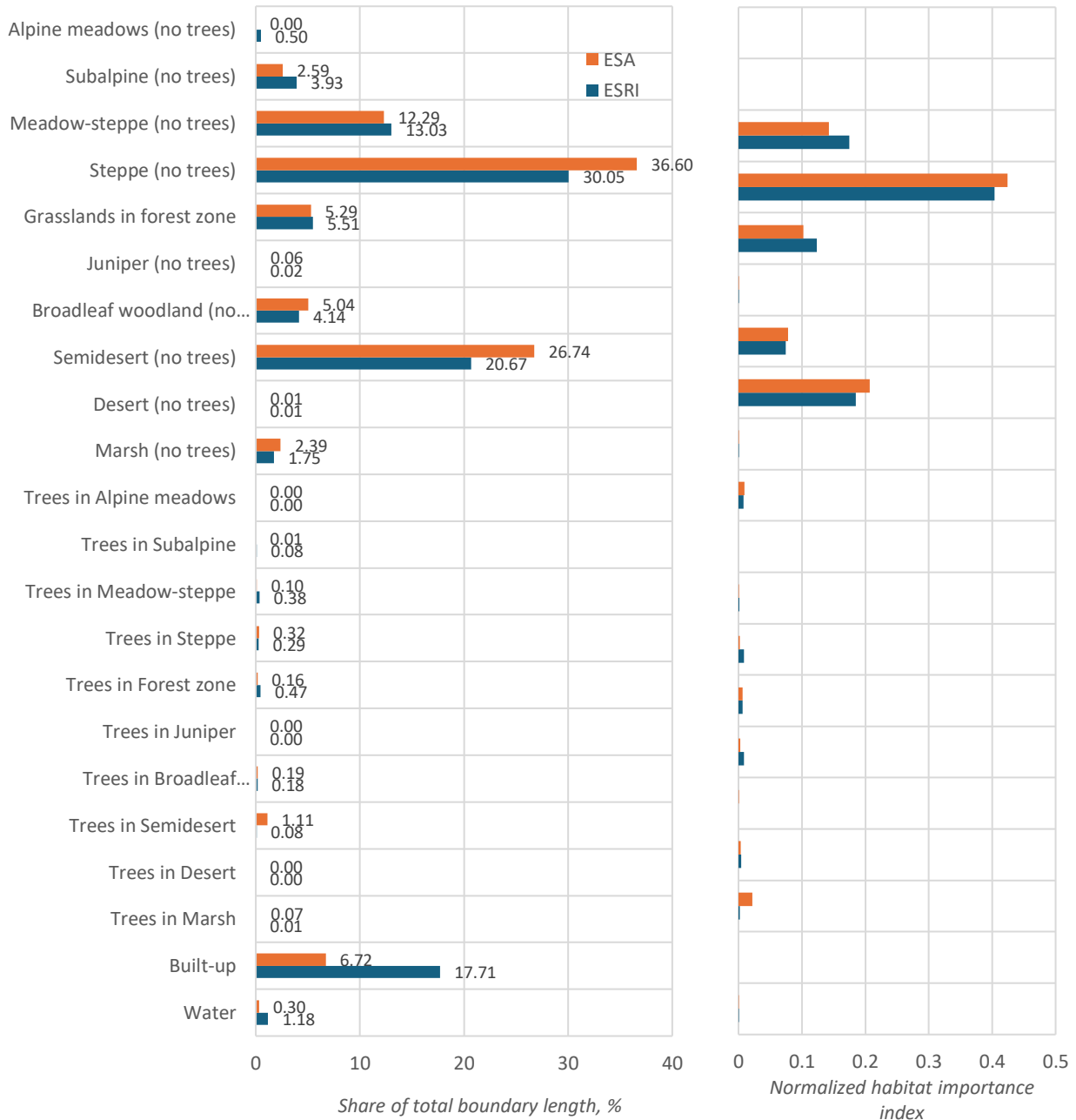

987

988

989

990

Figure 3.1.H-5. Share of the boundary between different ecosystem types and croplands relative to the total boundary length of croplands with other land cover classes (a), and the normalized importance index of different ecosystem types for crop pollination (b).

Mapping and evaluation of ES capacity/potential

The first step of ES assessment involved the generation of pollinator abundance maps across 20 types of natural habitats (Figures 3.1.H-1 and 3.1.H-2), based on the assigned abundance scores (Table 3.1.H-2). Subsequently, buffer zones extending into agricultural fields were delineated for each pollinator group according to their respective foraging ranges (*Hymenoptera* – 460 m, *Lepidoptera* – 260 m, *Diptera* – 260 m, *Coleoptera* – 160 m).

This approach resulted in spatial representations of pollinator abundance within natural habitats (shown in bright colours in Figures 3.1.H-6 to 3.1.H-9) and their presence zones within croplands (shown in pale colours in the same figures). Detailed maps are available in the project Web GIS: <https://bccarmenia.nextgis.com>, section "Ecosystem services. Pollination".

As shown in Table 3.1.H-2 and in the maps presented in Figures 3.1.H-6 to 3.1.H-9, *Hymenoptera* are the most abundant pollinator group across most of Armenia and also exhibit the largest foraging range into agricultural fields (460 m). *Diptera* rank second in terms of abundance, followed by *Lepidoptera*, which have a foraging range of 260 m. However, *Lepidoptera* are relatively more abundant in forest ecosystems, where *Diptera* are less numerous. *Coleoptera* are generally the least abundant group across most of the territory. However, in semi-desert zones—where the majority of pollinator-dependent crops are cultivated—they rank second after *Hymenoptera*, despite having the shortest foraging range into agricultural fields (160 m).

The maps also indicate that, when using the Esri land cover dataset, a substantial proportion of agricultural land appears inaccessible to pollinators, whereas the more detailed ESA land cover data suggest that pollinators can potentially occur across nearly the entire field area. The effect of higher spatial detail in the ESA dataset is particularly evident in the Ararat Valley, as illustrated by the map of *Coleoptera* foraging zones (Figure 3.1.H-9d), where areas of potential occurrence are visible around small patches of natural vegetation embedded within agricultural fields.

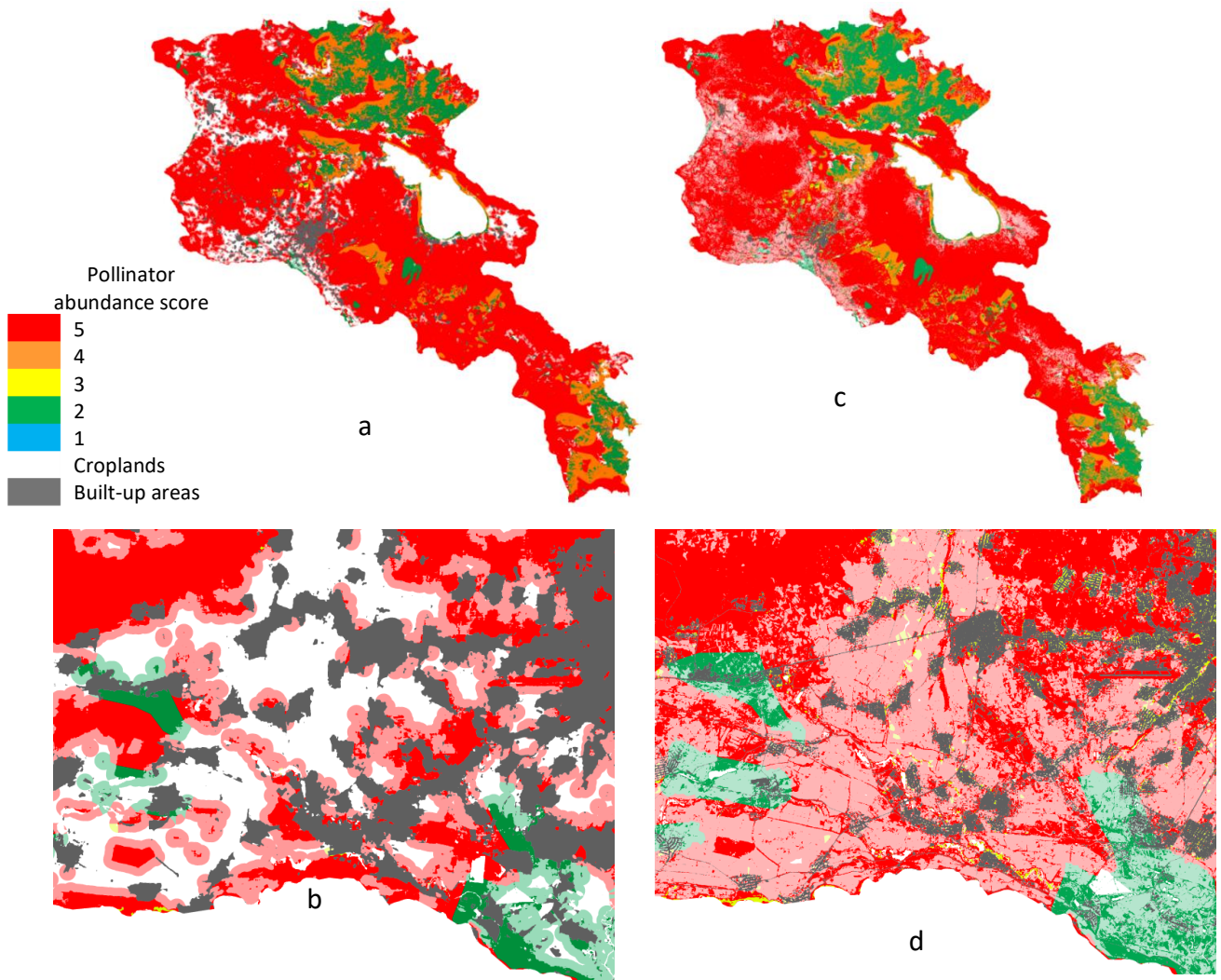
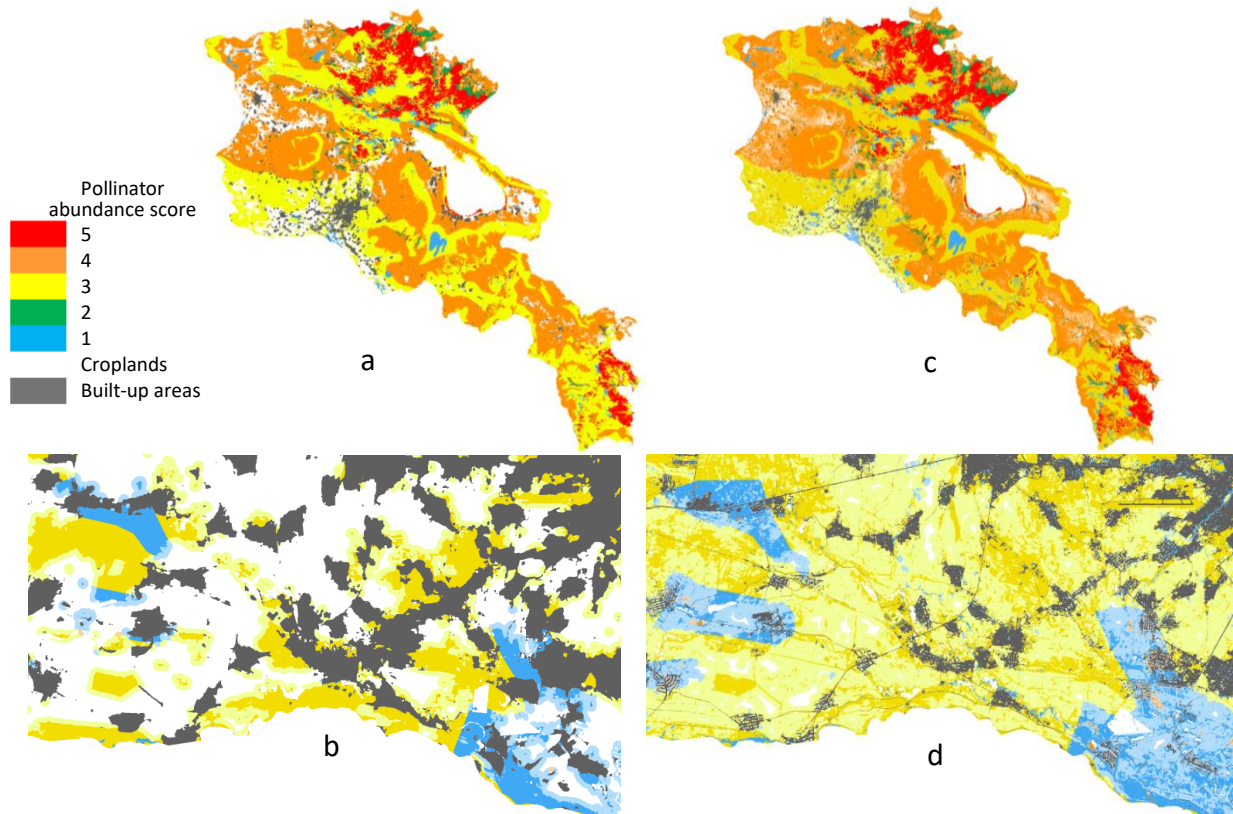

Figure 3.1.H-6. Pollination zones of *Hymenoptera*: (a, b) based on the Esri 2023 data; (c, d) based on the ESA 2021 data. The 460 m buffer within agricultural fields, representing areas reached by *Hymenoptera* from natural ecosystems, is shown in lighter colours. Enlarged map fragments of part of the Ararat Valley are presented at the bottom.



1016

1017

1018

1019

Figure 3.1.H-7. Pollination zones of *Lepidoptera*: (a, b) based on the Esri 2023 data; (c, d) based on the ESA 2021 data. The 460 m buffer within agricultural fields, representing areas reached by Hymenoptera from natural ecosystems, is shown in lighter colours. Enlarged map fragments of part of the Ararat Valley are presented at the bottom.

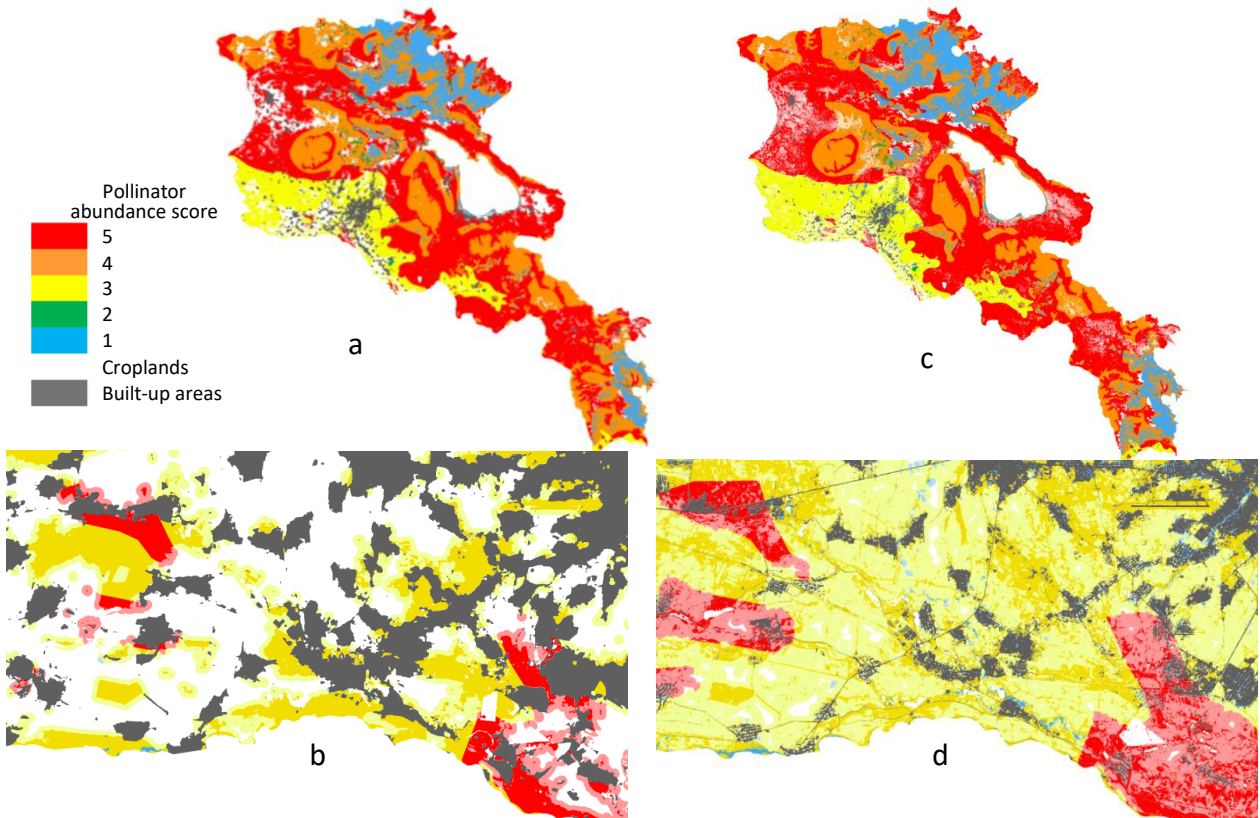

1020

1021

1022

1023

Figure 3.1.H-8. Pollination zones of *Diptera*: (a, b) based on the Esri 2023 data; (c, d) based on the ESA 2021 data. The 460 m buffer within agricultural fields, representing areas reached by Hymenoptera from natural ecosystems, is shown in lighter colours. Enlarged map fragments of part of the Ararat Valley are presented at the bottom.

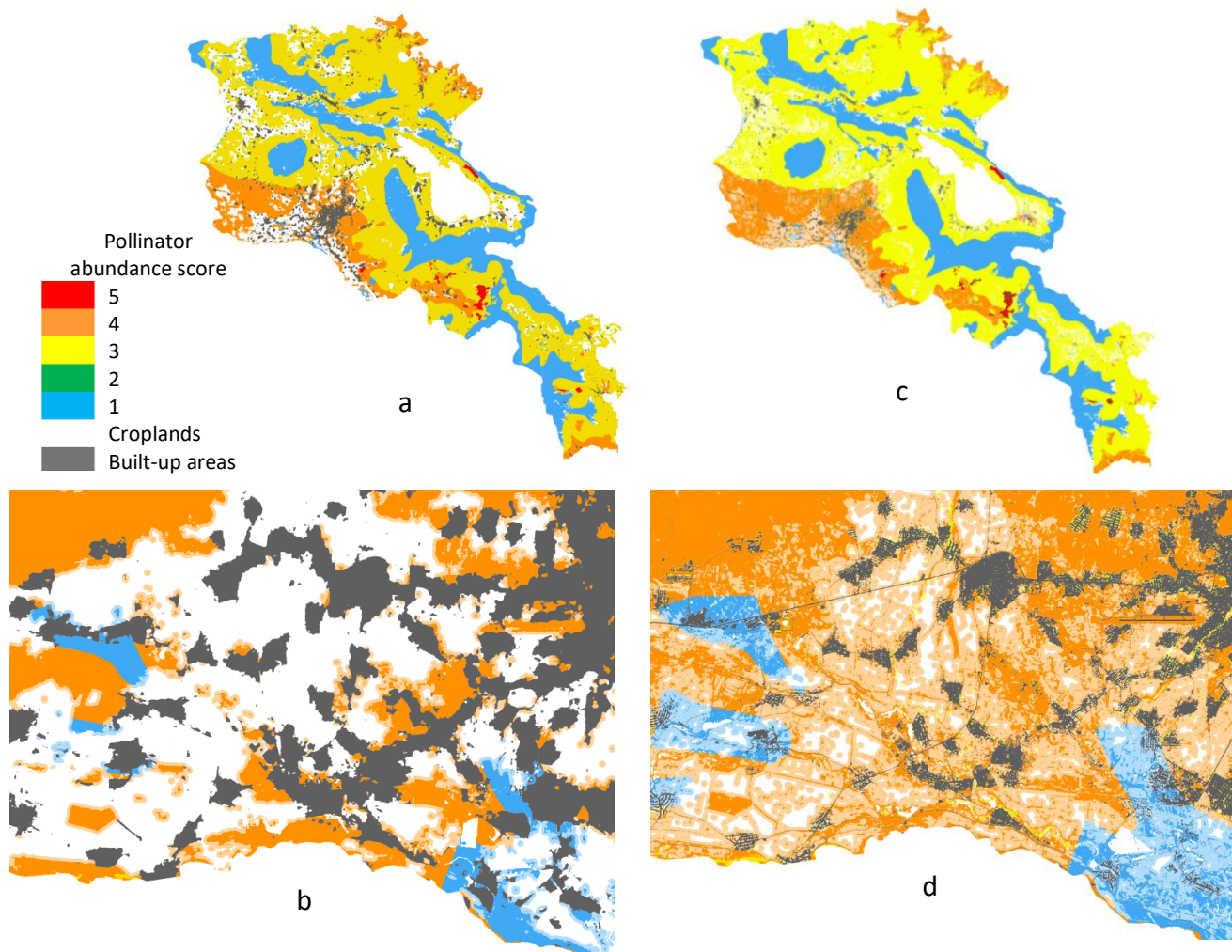

1024

1025

1026

1027

1028

1029

1030

1031

1032

1033

1034

1035

1036

1037

1038

1039

1040

1041

1042

1043

Figure 3.1.H-9. Pollination zones of Coleoptera: (a, b) based on the Esri 2023 data; (c, d) based on the ESA 2021 data. The 460 m buffer within agricultural fields, representing areas reached by Hymenoptera from natural ecosystems, is shown in lighter colours. Enlarged map fragments of part of the Ararat Valley are presented at the bottom.

Based on the mapped pollinator foraging zones within croplands, the potential pollination area was estimated (Figures 3.1.H-10 to 3.1.H-13, Appendix 3.1.H-4). Estimates derived from the Esri land cover dataset indicate substantially smaller potential pollination areas compared to those based on the more detailed ESA land cover dataset. For *Hymenoptera*, the estimated potential pollination area is 332,603 ha (99% of total cropland area) based on ESA data, compared to 221,555 ha (65%) based on Esri data. For *Coleoptera*, the corresponding estimates are 298,630 ha (89%) and 115,740 ha (34%), respectively. For *Lepidoptera* and *Diptera*, the estimated potential pollination areas correspond to 96% and 47% of total cropland land, respectively.

Across marzes, the largest potential pollination area within croplands is observed in Shirak marz (based on ESA data: from 64,667 ha to 53,149 ha across different pollinator groups; based on Esri data: from 43,048 ha to 21,668 ha). The smallest area is observed in Vayots Dzor marz (based on ESA data: from 6,100 ha to 6,089 ha; based on Esri data: from 3,129 ha to 2,136 ha). In relative terms, the highest share of cropland potentially covered by pollination is observed in Vayots Dzor marz (100% based on ESA data and from 97% to 80% based on Esri data across different pollinator groups). The lowest share of potentially pollinated cropland based on ESA data is observed in Shirak marz (from 98% to 80% across pollinator groups), while based on Esri data it is observed in Armavir marz (from 52% to 22%).

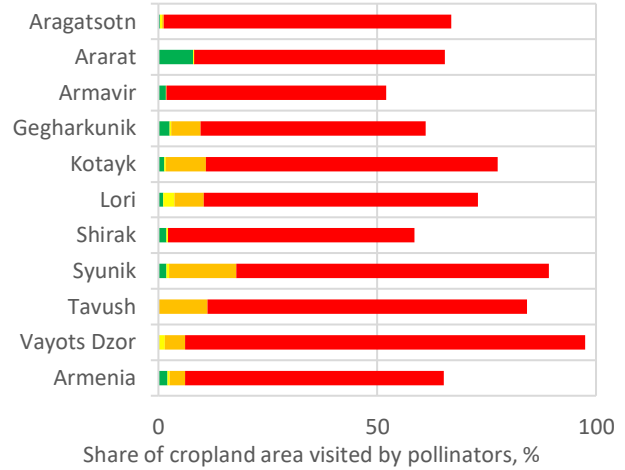
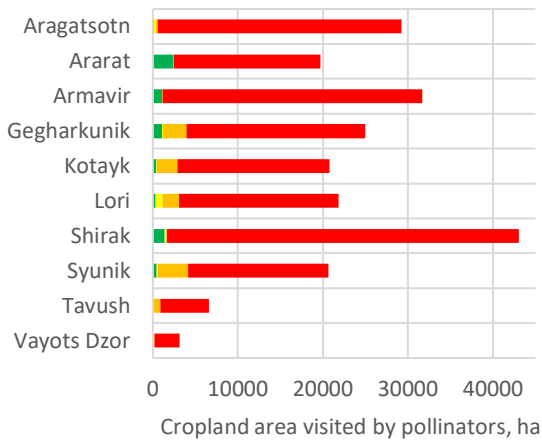

Score 2 Score 3 Score 4 Score 5

Score 2 Score 3 Score 4 Score 5

a

b

1044
1045

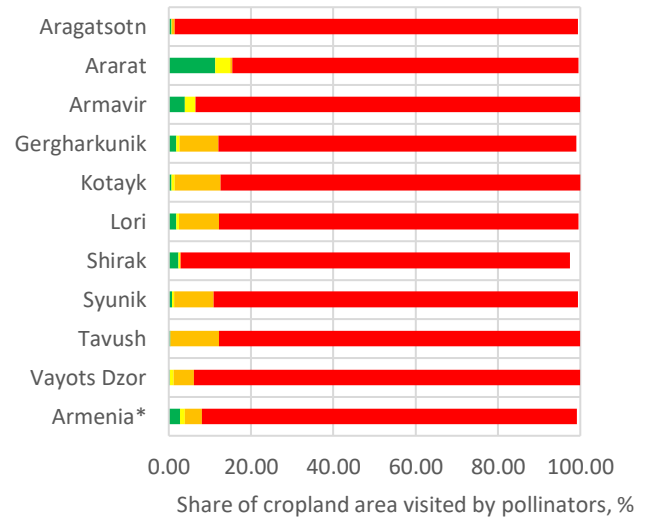
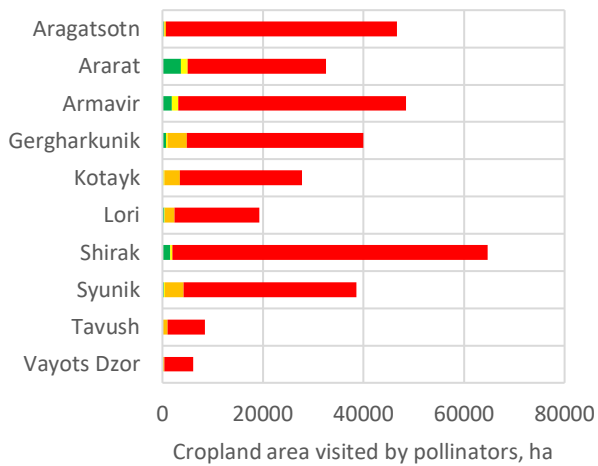

Score 2 Score 3 Score 4 Score 5

Score 2 Score 3 Score 4 Score 5

c

d

1046
1047

1048

1049

1050

Figure 3.1.H-10. Cropland area potentially visited by Hymenoptera: a,b) based on Esri land cover dataset; c,d) based on ESA land cover dataset

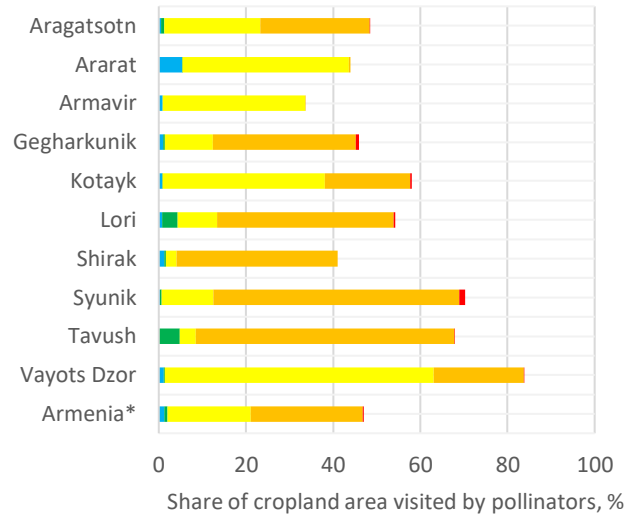
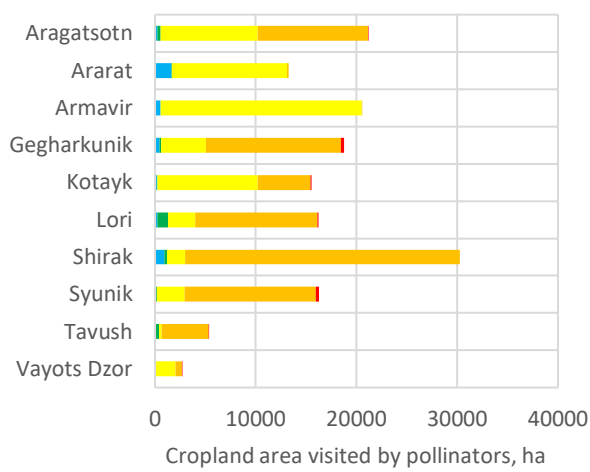

Score 1 Score 2 Score 3 Score 4 Score 5

Score 1 Score 2 Score 3 Score 4 Score 5

a

b

1051
1052

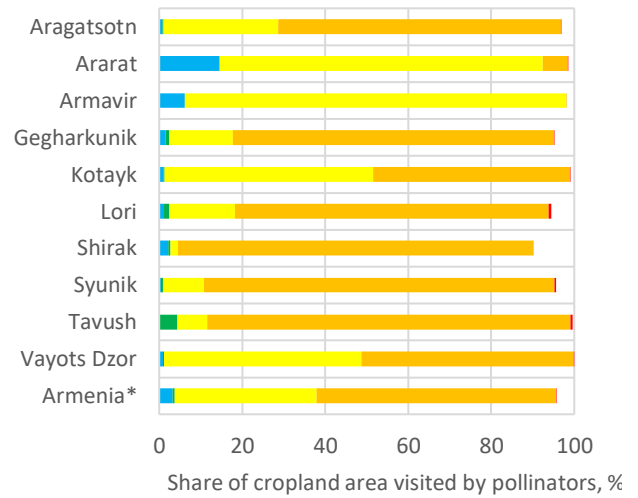
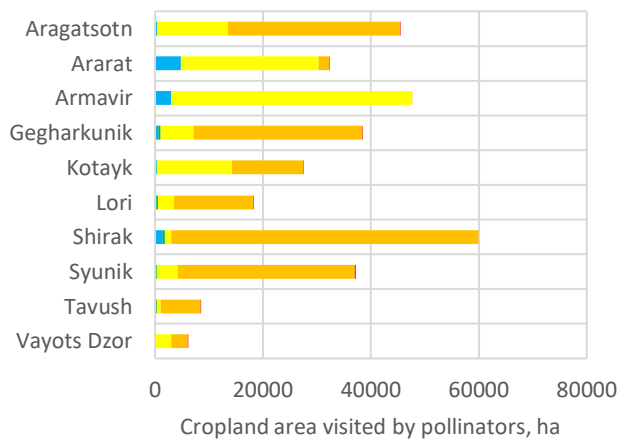

Score 1 Score 2 Score 3 Score 4 Score 5

Score 1 Score 2 Score 3 Score 4 Score 5

c

d

1053
1054

1055
1056

Figure 3.1.H-11. Cropland area potentially visited by Lepidoptera: a,b) based on Esri land cover dataset; c,d) based on ESA land cover dataset

1057

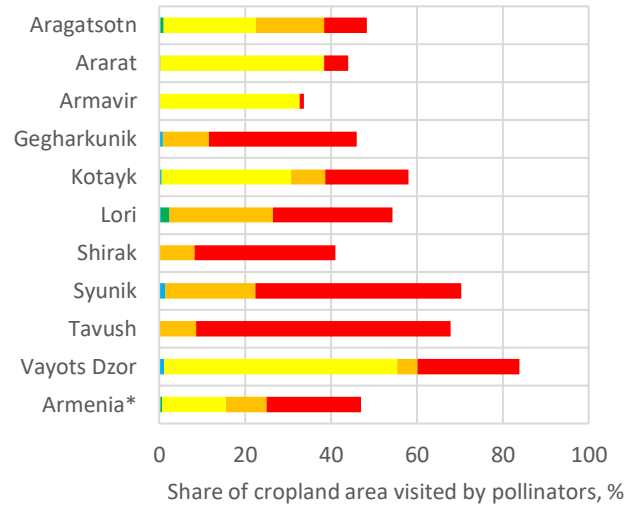
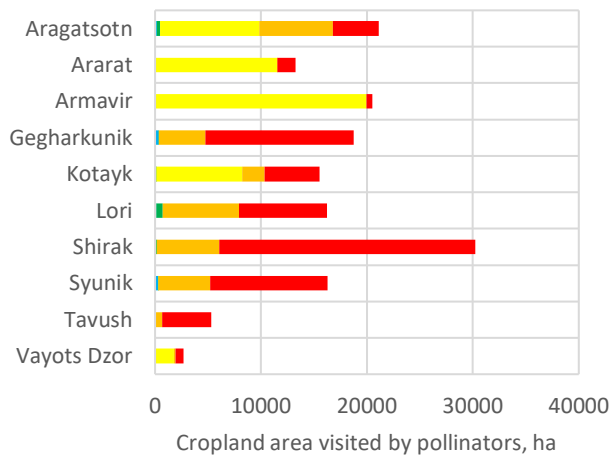

Score 1 Score 2 Score 3 Score 4 Score 5

Score 1 Score 2 Score 3 Score 4 Score 5

1058
1059

a

b

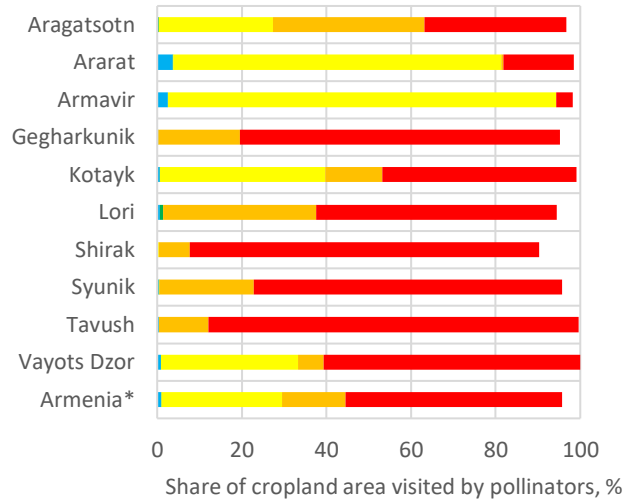
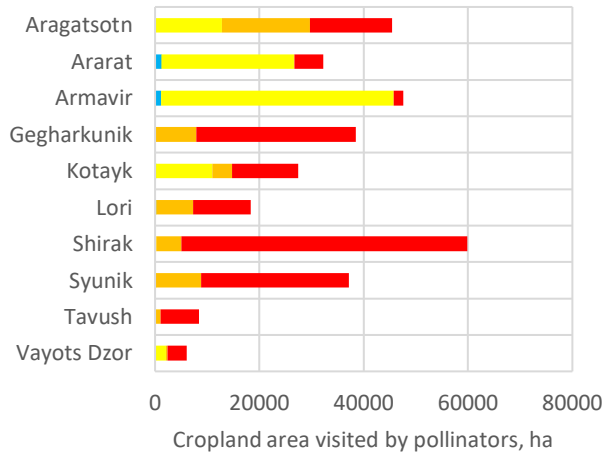

Score 1 Score 2 Score 3 Score 4 Score 5

Score 1 Score 2 Score 3 Score 4 Score 5

1060
1061

c

d

1062
1063

Figure 3.1.H-12. Cropland area potentially visited by Diptera: a,b) based on Esri land cover dataset; c,d) based on ESA land cover dataset

1064



1065
1066

1067
1068

1069
1070

1071

Figure 3.1.H-13. Cropland area potentially visited by Coleoptera: a,b) based on Esri land cover dataset; c,d) based on ESA land cover dataset

Assessment of ES use

1072
1073
1074
1075
1076
1077
1078
1079
1080
1081
1082
1083
1084
1085
1086

Mapping of ES use requires spatial data on the distribution of entomophilous crops, as the service is utilized specifically in these areas. Such spatial data were not available at this stage; therefore, ES use was estimated based on averaged statistical data on the total area of entomophilous crops at the marz level from Armstat (Table 3.1.H-4). The highest shares of entomophilous crops are observed in Vayots Dzor, Ararat, and Armavir marzes (43–50%), while the lowest shares are observed in Shirak and Gegharkunik marzes (1–5%) (Figure 3.1.H-14).

In the absence of spatial crop maps, a uniform distribution of entomophilous crops across total cropland area was assumed. Under this assumption, the actually pollinated area in marz *i* was estimated as: $S_i = S_{pi} \times F_i$, where S_{pi} is the potential pollination area of agricultural land in marz *i*, and F_i is the share of entomophilous crops in marz *i*. Results for *Hymenoptera*, as the most abundant and active pollinators, are presented in Table 3.1.H-4 and Figure 3.1.H-15. Based on these averaged estimates, the largest actually pollinated area is observed in Armavir marz (13,706 ha and 20,935 ha based on Esri and ESA data, respectively), while the smallest is observed in Shirak marz (628 ha and 943 ha). The total actually pollinated cropland area in Armenia is estimated at 46,744 ha and 71,317 ha based on Esri and ESA data, respectively.

1087
1088

Table 3.1.H-4. Area of agricultural crops in marzes based on Armstat data, 2023 (ha) and pollinated area by Hymenoptera

	Aragatsotn	Ararat	Armavir	Gegharkunik	Kotayk	Lori	Shirak	Syunik	Tavush	Vayots Dzor	Total
Sown areas under grains	17281	2246	3921	21683	9414	12614	36681	17884	4337	1030	127091
Sown areas under potatoes	880	489	1408	6533	631	3440	3635	894	648	86	18644
Sown areas under vegetables	232	4080	7920	1035	828	1125	1191	486	650	218	17765
Planting areas of grape	1452	4722	6471	-	69	37	-	180	1342	1205	15478
Total area of non-entomophilous crops	19845	11537	19720	29251	10942	17216	41507	19444	6977	2539	178978
Sown areas under water-melons	38	1006	2825	-	0	5	-	11	32	16	3933
Planting areas of fruits and berries	6467	8892	12188	1562	4611	2357	614	2650	2998	2561	44900
Total area of entomophilous crops	6505	9898	15013	1562	4611	2362	614	2661	3030	2577	48833
Total cropland area	26350	21435	34733	30813	15553	19578	42121	22105	10007	5116	227811
Share of the area of entomophilous crops,%	25	46	43	5	30	12	1	12	30	50	
Potentially pollinated cropland area based on Esri data	29237	19689	31710	24944	20751	21825	43048	20651	6570	3129	221555
Potentially pollinated cropland area based on ESA data	46692	32590	48434	39996	27712	19292	64667	38639	8480	6100	332603
Actually pollinated cropland area based on Esri data	7218	9092	13706	1264	6152	2633	628	2486	1989	1576	46744
Actually pollinated cropland area based on ESA data	11527	15049	20935	2027	8216	2328	943	4651	2567	3073	71317

1089

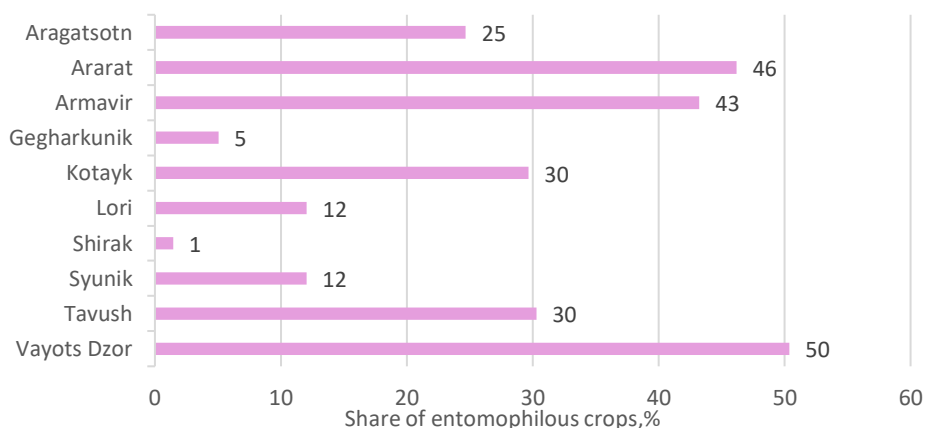

1090
1091
1092

Figure 3.1.H-14. Share of the area of entomophilous crops across marzes, %

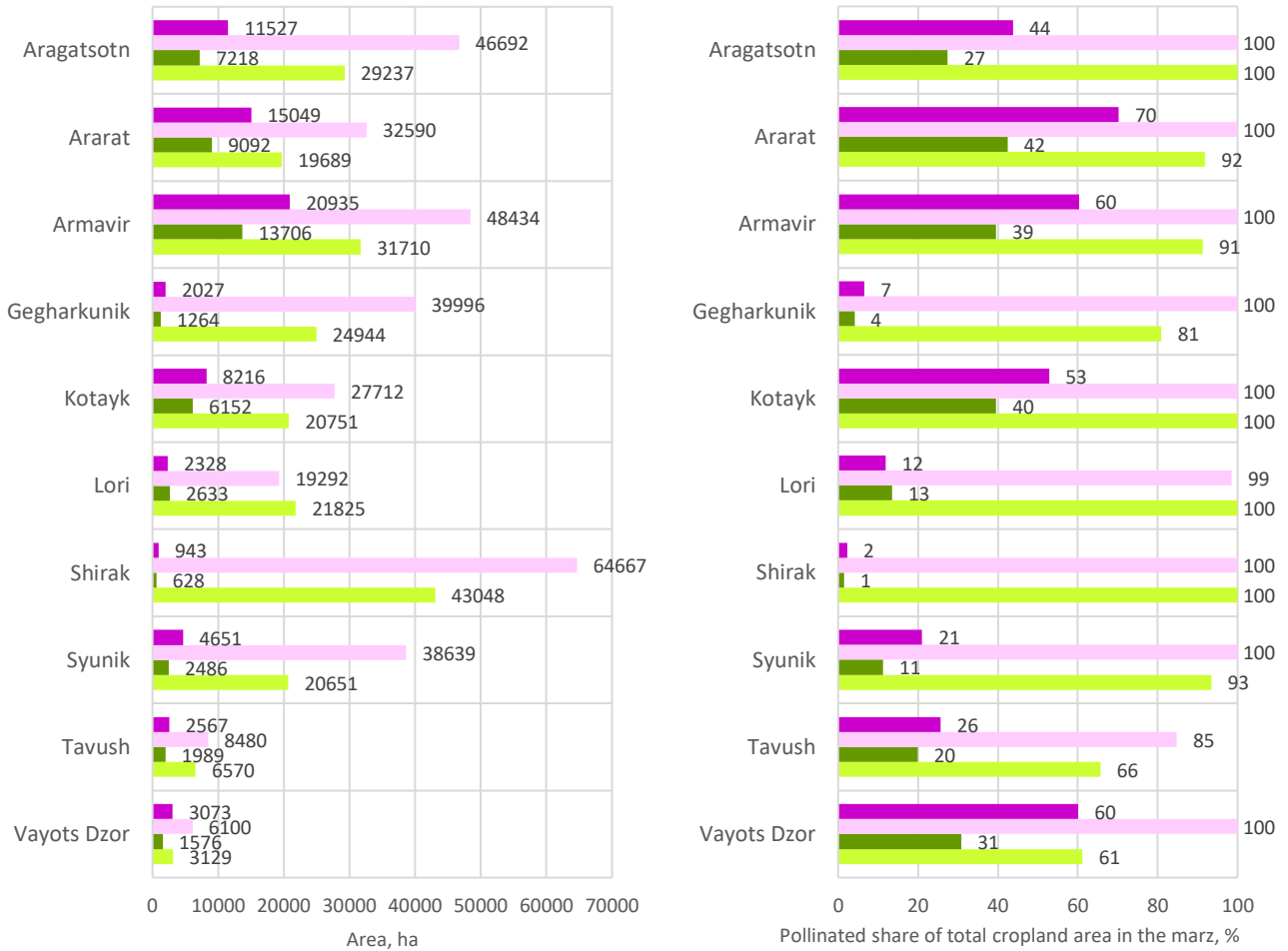

1093

- Actually pollinated cropland area based on ESA data
- Potentially pollinated cropland area based on ESA data
- Actually pollinated cropland area based on ESRI data
- Potentially pollinated cropland area based on ESRI data

1094

1095

Figure 3.1.H-15. Actually and potentially pollinated area across marzes (left) and pollinated share of total cropland area in the marz (right) based on Esri and ESA land cover data. Potentially pollinated area refers to all cropland, while actually pollinated area accounts for the share of entomophilous crops in the marz.

1096

1097

1098

The main conclusions that can be drawn from this assessment of pollination ES are as follows:

1099

- Mapping and assessment of potential pollination ES should be based on land cover data that accurately represent the spatial distribution of croplands and pollinator habitats within agricultural landscapes.
- Assessment of ES use requires maps of the distribution of entomophilous crops.
- The presence of even small patches of pollinator habitats within agricultural landscapes substantially increases the potential pollination area. Assessments that account for fine-scale habitat patches within croplands indicate that pollinators may potentially occur across nearly the entire cropland area.
- To enhance pollination ES, it is recommended to conserve and restore pollinator habitats, maintain shelterbelts (windbreak tree lines), and install artificial nesting structures (insect hotels) in proximity to agricultural fields.

1100

1101

1102

1103

1104

1105

1106

1107 **3.1.1. Regulating ES of protected areas**

1108 At the present stage, we do not have access to official data covering all Armenian PAs for the period after 2014, official
 1109 digitized maps of PA boundaries, or land cover data specifically refined for the territory of Armenia. Therefore, the
 1110 following analyses are based on the available digital PA map referenced below and the global Esri land cover dataset.

1111 The use of the Esri land cover dataset for relatively small PA areas leads to significant errors in area estimation. In the
 1112 examples below, we demonstrate only the type of analysis that can, in principle, be conducted for ecosystem accounting
 1113 of PAs based on land cover data. **All estimates are of methodological value only and should be refined using official PA**
 1114 **boundaries and land cover data provided by the PAs.**

1116 This example of accounting is based on the PA map provided by Acopian Center for the Environment, American
 1117 University of Armenia³⁰ (Figure 3.1.1-1), the vegetation map prepared in the framework of our project (Section 2.3), and
 1118 Esri land cover data from 2017 and 2023.

1119

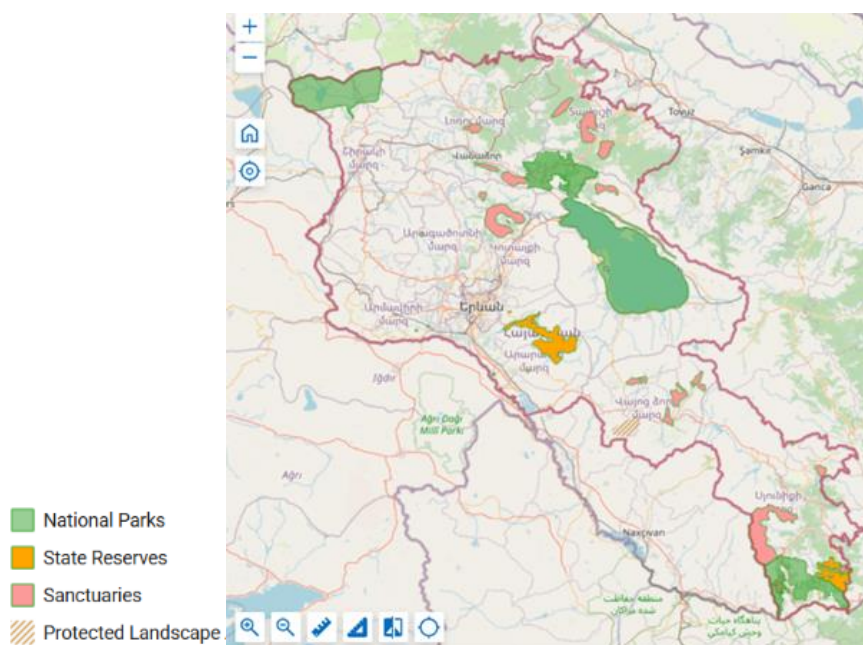

1120

1121 *Figure 311-1. The map of protected areas of Armenia. For details see project Web GIS <https://bccarmenia.nextgis.com/>,*
 1122 *section "Protected areas" (the location of the Goravan Sands Sanctuary needs to be clarified)*

1123 **ES of seasonal flow regulation and baseflow provision**

1124 In most PAs, the baseflow is lower than the national average for Armenia (Figure 3.1.1-2). However, in some PAs, it
 1125 significantly exceeds the average values. The highest baseflow has been identified in Aragats Alpine sanctuary, Arpi Lake
 1126 National Park and Pine of Banx sanctuary, which are in regions with relatively high precipitation. These three PAs are in
 1127 alpine, subalpine and meadow-steppe vegetation zones (Section 2.6.B), which are characterized by both a high level of
 1128 baseflow and a high proportion of baseflow in the total water flow (Section 3.1.A).

1129 **ES of flood risk mitigation**

1130 In most PAs, the runoff retention is higher than the national average for Armenia (Figure 3.1.1-3). The lowest values
 1131 of runoff retention are observed in PAs located in the Ararat Valley, which has been heavily modified by human activity.
 1132 The pattern for runoff retention differs from that of baseflow, as it reflects the influence of land cover and soil type, but
 1133 does not account for topography.

1134 **ES of prevention of soil erosion and sediment transport into waterbodies**

1135 Value of avoided erosion in most protected areas exceeds the national average for Armenia. This is explained by the
 1136 fact that PAs are primarily composed of natural grasslands and forests, which effectively prevent erosion (Section 2.6.B).
 1137 All PAs where Indicator avoided erosion exceeds 100 t/ha/year are mostly or entirely covered by woody vegetation, with
 1138 the exception of the Goris sanctuary, which has a small forested area (Figure 3.1.1-4).

³⁰ <https://ace.aua.am/>

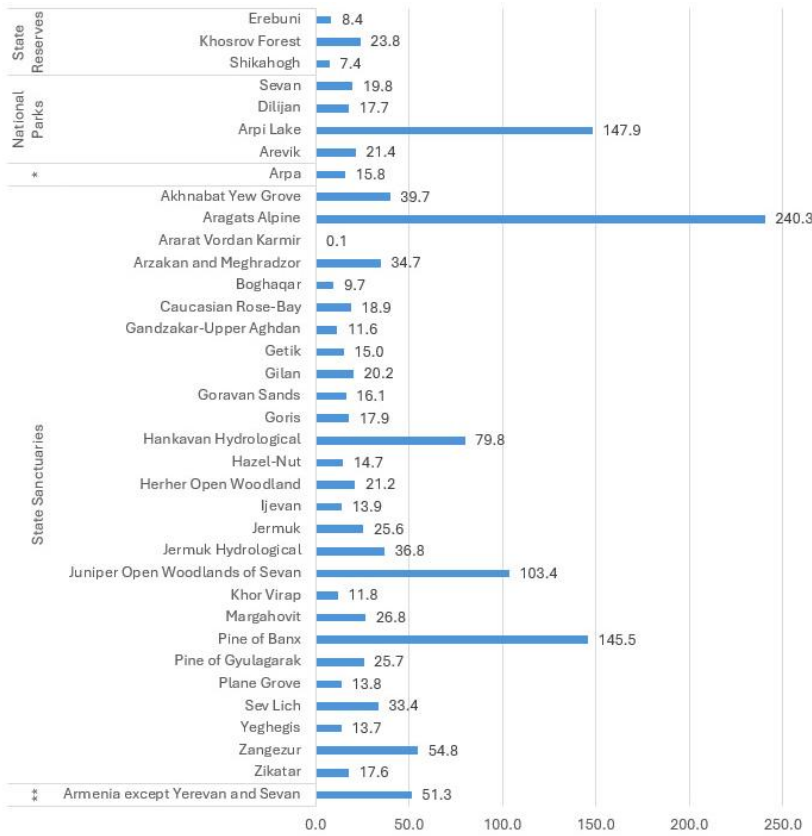

1139

1140

Figure 3.1.I-2. Baseflow in PAs, mm

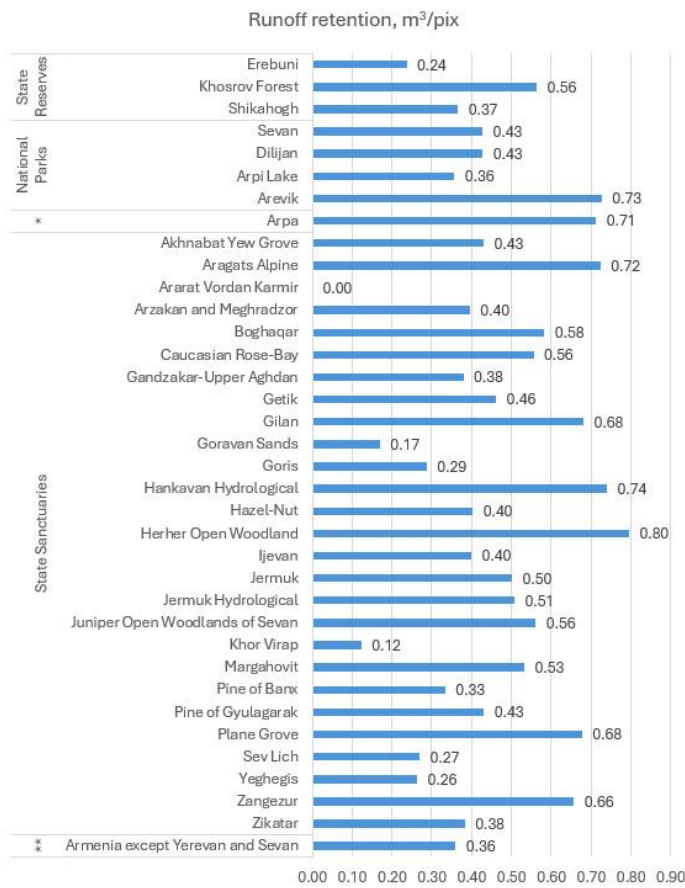

1141

1142

Figure 3.1.I-3. Runoff retention in PAs, m³/pixel

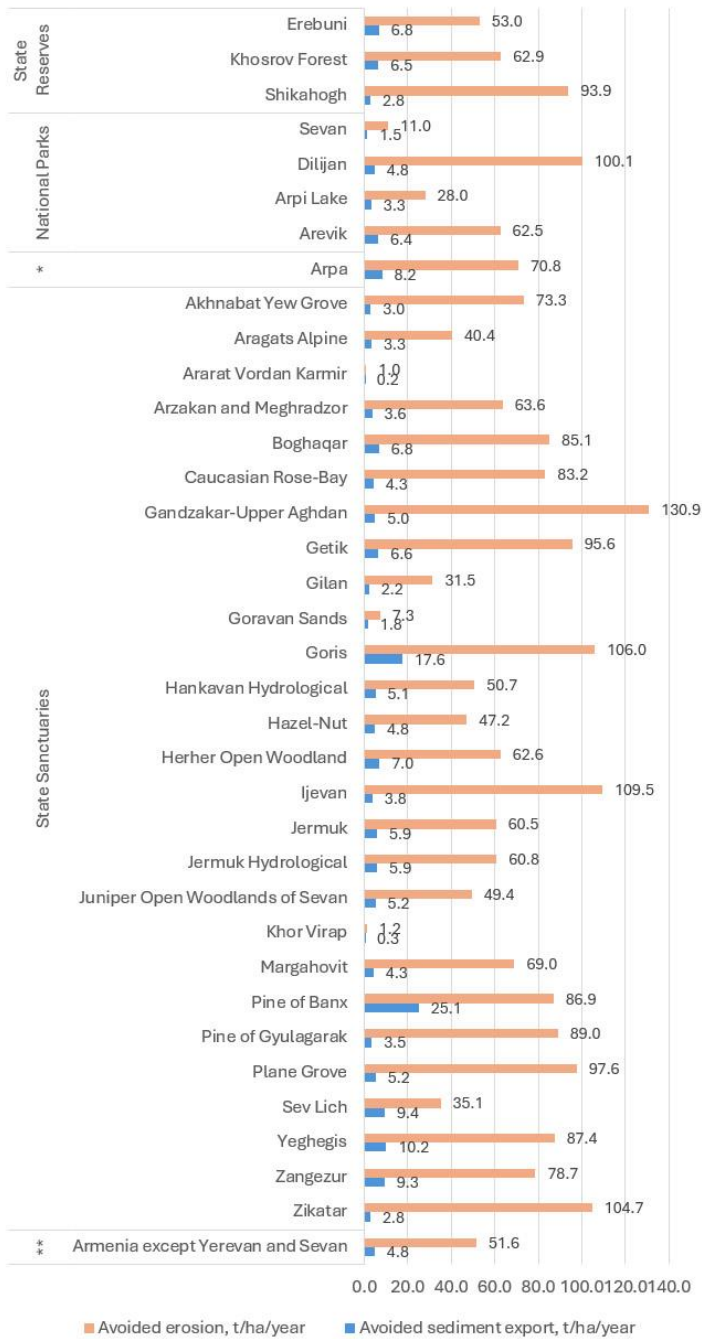

Figure 3.1.1-4. Indicators of the ES of prevention of erosion and sediment delivery to water bodies

Carbon storage in PAs

Carbon content in soil in the PAs fluctuate around the national average for Armenia. PAs located in the semi-desert zone have the lowest soil carbon content. The total carbon stock depends primarily on the size of each PA. The highest carbon stock in tree biomass is found in Dilijan National Park, which has the largest forest area (Figure 3.1.D-5). ES assessment for small PAs based on low-resolution maps is not advisable. For example, for the sanctuary Sev Lich, are inaccurate due to the low resolution (250 m) of the soil carbon map used (Figure 3.1.D-6). The carbon map we used accounts for carbon content only in terrestrial ecosystems, assigning a value of zero to water bodies. The sanctuary Sev Lich includes part of a water body. Due to the low resolution of the map, pixels with zero values overlapped significant part of small terrestrial area of this sanctuary. As a result, both the average soil carbon content and the total carbon stock in this PA are significantly underestimated.

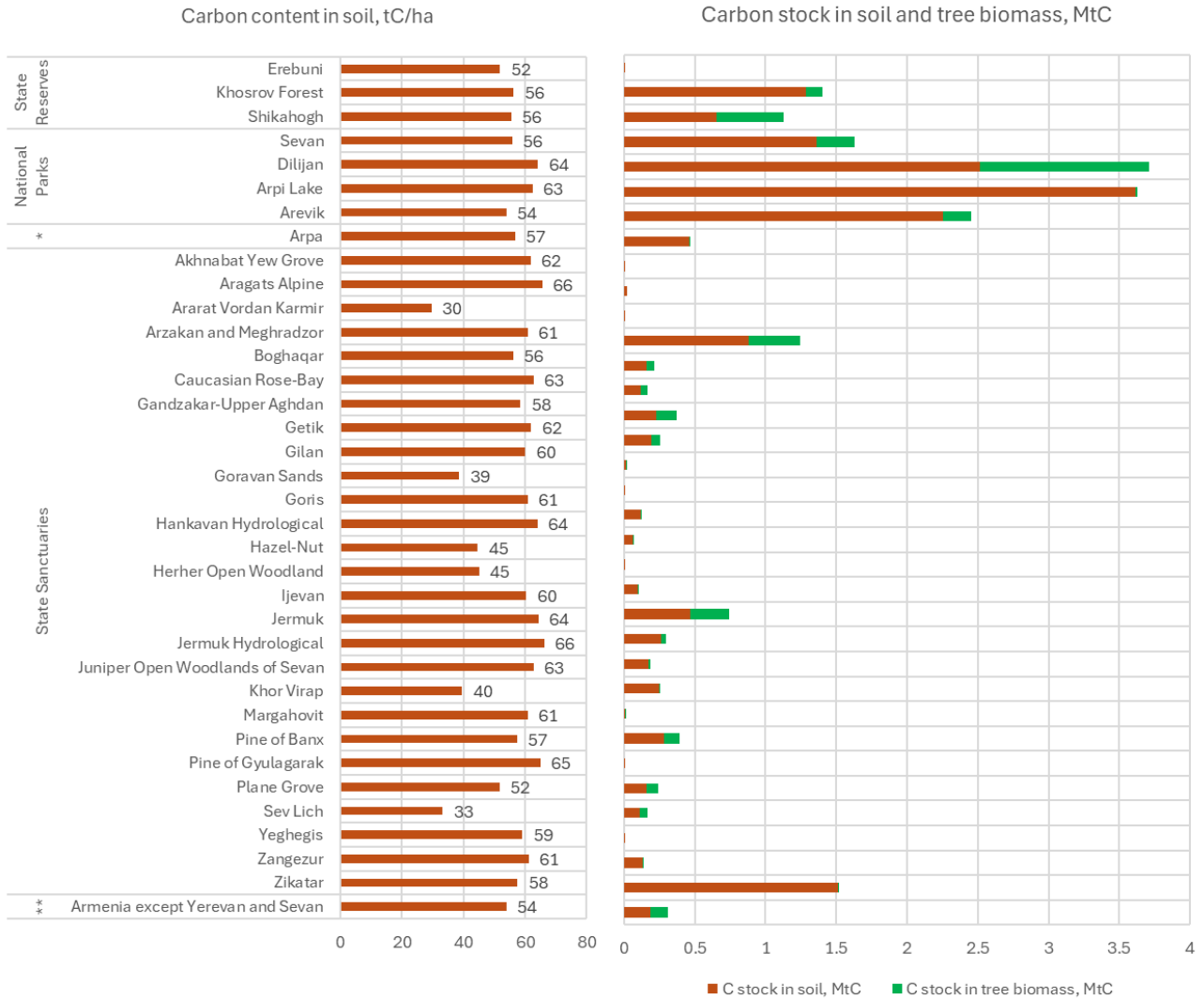

Figure 3.1.I-5. Carbon content in soil and total carbon stock in PAs

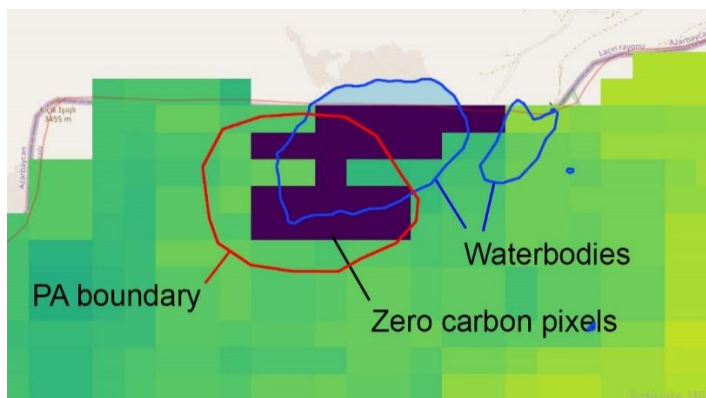
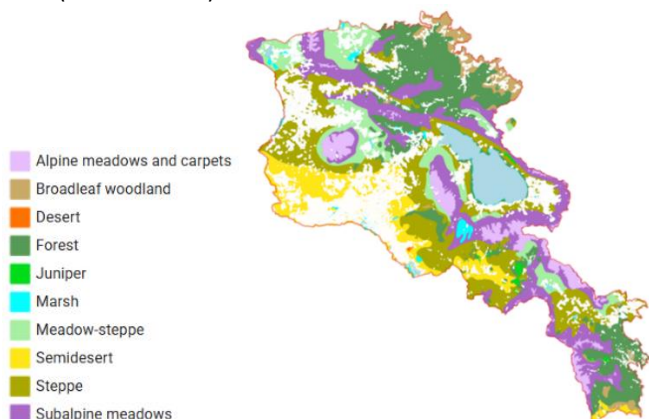

Figure 3.1.I-6. An example of a significant error in estimating carbon content in a small PA is observed in the case of the sanctuary Sev Lich.

1162

3.2. Provisioning services

1163 The assessment of supplied provisioning ES was made based on the vegetation map created in the project framework
 1164 excluding crops and built-up areas (Section 2.3.A).



1165
1166

3.2.A. Fodder production on natural pastures and hayfields

1167

3.2.A1. Provided potential ES

1168

1169 The volume of provided ES is equal to the amount of fodder that can be used by livestock without harming pasture
 1170 condition, that is, the maximum allowable stocking rate. The Government of Armenia Decision No. 389-N of 14 April
 1171 2011³¹ defines this value for the main grassland zones in Armenia (Table 3.2.A1-1). These values are defined based on
 1172 the relationship between grassland productivity and livestock demand for forage, so they can also be applied to hayfields.
 1173 Hereafter, for brevity, we will use the term “pastures” to also include hayfields. Livestock numbers were converted to
 1174 livestock units (LU), with 1 LU defined as one 500-kg cow.

1175 *Table 3.2.A1-1. Pasture area required to maintain one livestock unit (LU) for the entire grazing season, as defined in*
 1176 *Government of Armenia Decision No. 389-N, and the maximum permissible stocking density recalculated from the mean*
 1177 *required pasture-area values.*

Grassland types	Pasture area required per LU for the entire grazing season, ha		Maximum allowable stocking rate (LU/ha)
	Range of values	Average	
Alpine	2 - 2.5	2.25	0.44
Subalpine	1 - 1.2	1.1	0.91
Meadow-steppe and post-forest grasslands	1.5 - 1.7	1.6	0.63
Steppe	2 - 2.5	2.25	0.44
Semi-desert	6 - 7	6.5	0.15

1178

1179 For the preliminary ES mapping based on the vegetation map, we adopted the values shown in Table 1 for analogous
 1180 vegetation zones and for open woodlands, we used the steppe-zone value of 0.44. Forests (tree cover) and marshes were
 1181 excluded from the pasture category. The desert is also excluded because it has a very small area and no maximum grazing
 1182 load has been established for it.

1183 The map of the maximum permissible stocking rate (Figure 3.2.A1-1 a) shows the ES capacity. Totally, subalpine
 1184 meadows provide the largest amount of livestock forage (maximum permissible total number of livestock units—390,000
 1185 LU), with other grasslands contributing a substantial share (163,000 – 230,000 LU). Semi-desert and woodlands provide
 1186 the least of this ES due to their low productivity and limited extent (Figure 3.2.A1-1 b).

1187 Across marzes, the highest LU capacity is in the Gegharkunik and Syunik marzes (over 200,000 LU), with at least half
 1188 of this number provided by alpine and subalpine grasslands. The lowest capacity is in Armavir marz (3.2.A1-2).
 1189

³¹ <https://www.arlis.am/DocumentView.aspx?DocID=67394>

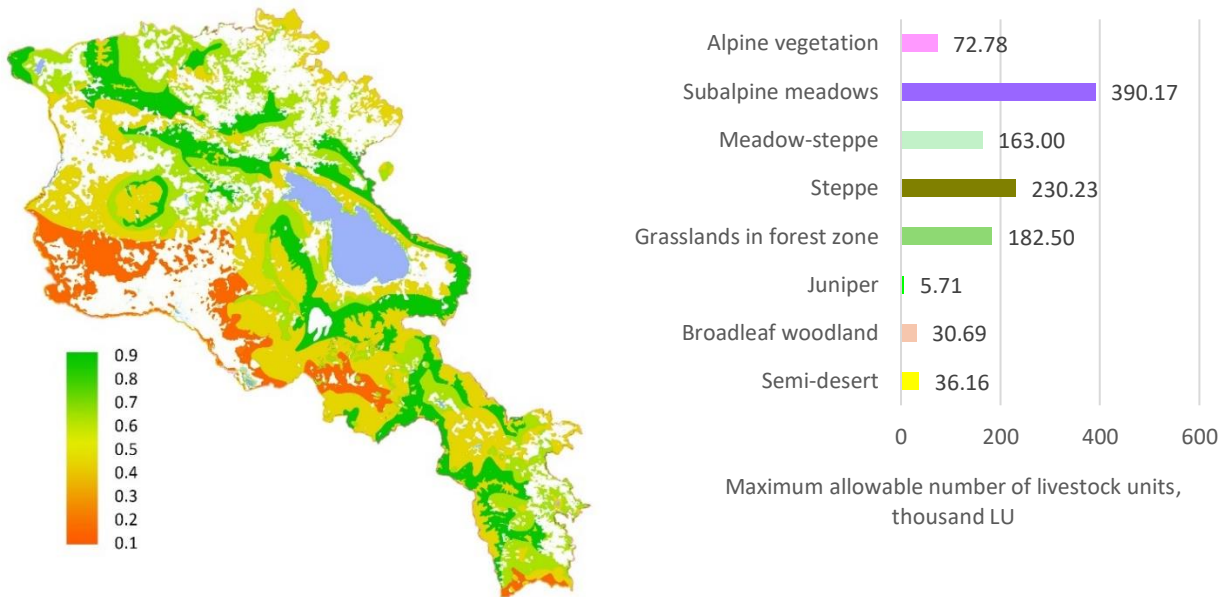

1190

1191

1192

Figure 3.2.A1-1. ES capacity: a) The map of maximum permissible stocking rate (LU/ha); b) ES capacity in different vegetation types, thousand LU

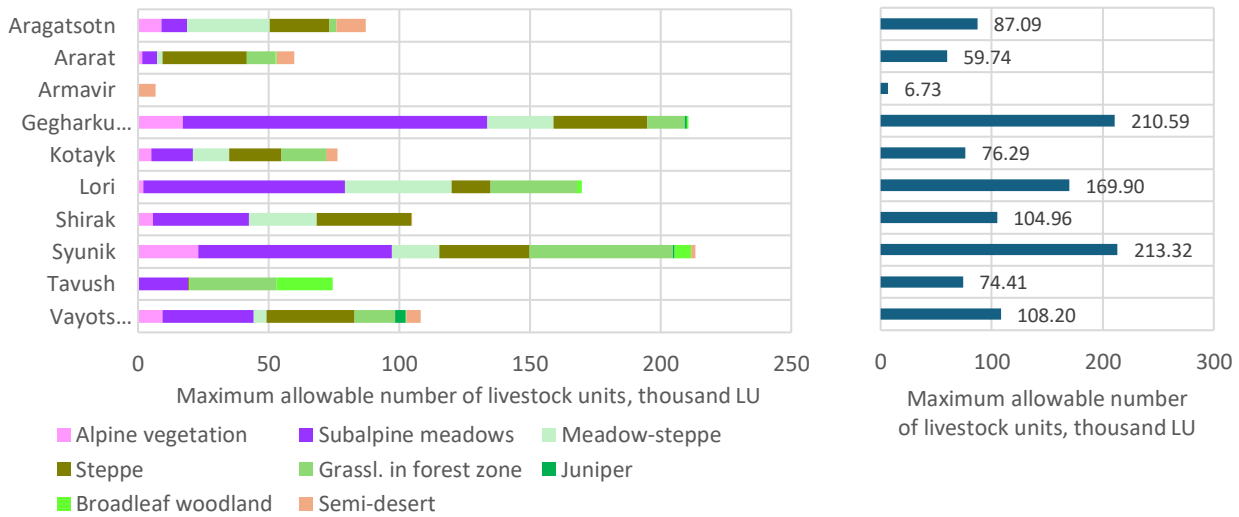

1193

1194

1195

Figure 3.2.A1-2. ES capacity in 2023: maximum allowable total number of livestock units (LU) in different vegetation types across marzes

1196

1197

Table 3.2.A1-2. ES capacity in 2023: maximum allowable total number of livestock units (LU) in different vegetation types across marzes, thousand LU

	Alpine vegetation	Subalpine meadows	Meadow-steppe	Steppe	Grasslands in forest zone	Juniper	Broadleaf woodland	Semi-desert	Total
Aragatsotn	9.00	9.75	31.67	22.77	2.70	0.00	0.00	11.20	87.09
Ararat	1.64	5.72	1.94	32.26	11.10	0.00	0.42	6.66	59.74
Armavir	0.00	0.00	0.00	0.00	0.00	0.00	0.00	6.73	6.73
Gegharkunik	17.16	116.55	25.22	35.98	14.30	0.92	0.47	0.00	210.59
Kotayk	5.01	16.01	13.97	19.87	17.17	0.00	0.07	4.18	76.29
Lori	1.98	77.16	40.92	14.84	33.16	0.00	1.84	0.00	169.90
Shirak	5.65	36.75	26.05	36.25	0.00	0.00	0.00	0.26	104.96
Syunik	23.07	73.99	18.34	34.38	54.92	0.55	6.41	1.65	213.32
Tavush	0.01	19.19	0.00	0.29	33.64	0.00	21.27	0.00	74.41
Vayots Dzor	9.27	35.04	4.90	33.59	15.50	4.24	0.20	5.47	108.20
Total	72.78	390.17	163.00	230.23	182.50	5.71	30.69	36.16	1111.24

1198 **3.2.A2. Changes in ES capacity from 2017 to 2023**

1199 Changes in carbon stock in natural areas of different vegetation types were assessed on the basis of changes in area
 1200 of vegetation types from accounting table for ecosystem extent (Table 2.3.C-2) using the indicator of carbon content per
 1201 ha across different vegetation types in 2023 (Table 3.1.G1-1). In this calculation, we did not take into account the changes
 1202 in per-hectare ES potential values between 2017 and 2023. This approach makes it possible to calculate the data for the
 1203 table recording the dynamics of the ES potential/capacity (Table 3.1.G2-1).

1204 *Table 3.2.A2-1. Accounting table for ES capacity changes, thousand LU*

	Alpine vegeta-tion	Subalpine meadows	Meadow-steppe	Steppe	Grassl. in forest zone	Juni-per	Broadleaf wood-land	Semi-desert	Total
Opening ES capacity in 2017	72.42	391.34	179.01	239.50	179.56	5.67	31.27	37.18	1135.95
Additions to ES capacity	0.21	7.00	2.22	8.50	16.93	0.10	2.52	2.89	40.36
Managed/unmanaged	NA								
Reductions ES capacity	0.13	7.63	18.23	17.77	13.99	0.05	3.09	3.05	63.95
Managed/unmanaged	NA								
Net change ES capacity	0.08	-0.63	-16.01	-9.27	2.94	0.04	-0.57	-0.16	-23.59
Closing ES capacity in 2023	72.50	390.71	163.01	230.23	182.50	5.71	30.70	37.01	1112.37
Additional row – see discussion below									
Closing ES capacity in 2023 of eco-systems unconverted since 2017	72.29	383.71	160.78	221.74	165.57	5.61	28.18	34.12	1072.00

1205 Changes in land cover recorded by Esri from 2017 to 2023 led to a reduction of ES capacity. The greatest reduction
 1206 occurred in the meadow-steppe and steppe zones, with the allowable livestock numbers decreasing by 16000 and 9000
 1207 LU, respectively (Figure 3.2.A2-1).

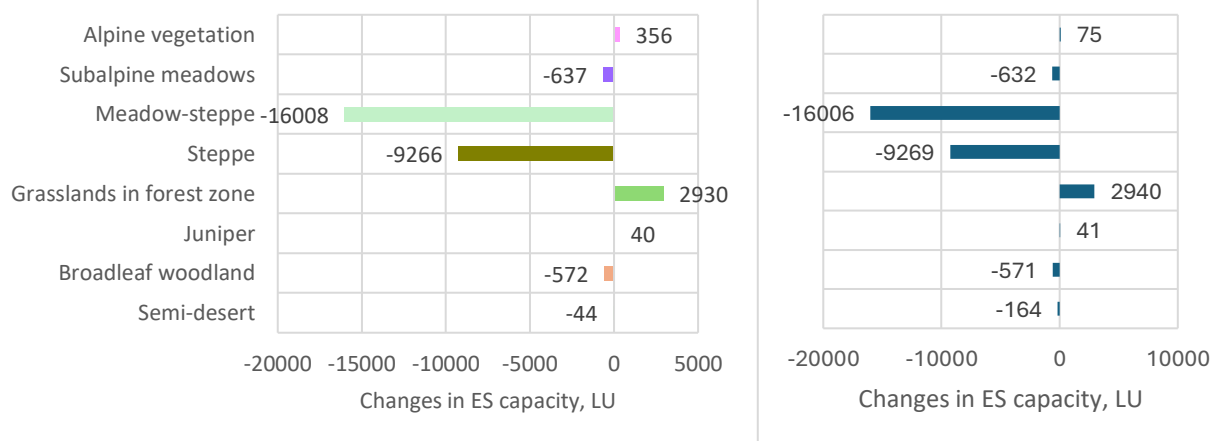

1208
 1209 *Figure 3.2.A2-1. Changes in ES capacity from 2017 to 2023 in different ecosystem types across marzes*

1210 Across marzes, the greatest reduction of ES capacity occurred in Shirak marz, reducing their total capacity by 12,000
 1211 LU. A noticeable reduction in carrying capacity—by thousands of LU —also occurred in Aragatsotn, Gegharkunik and Lori
 1212 marzes, while ES capacity increased in Syunik marz. Across all marzes, the decline in capacity was driven primarily by the
 1213 reduction in the area of steppe and meadow-steppe (Figure 3.2.A2-2).

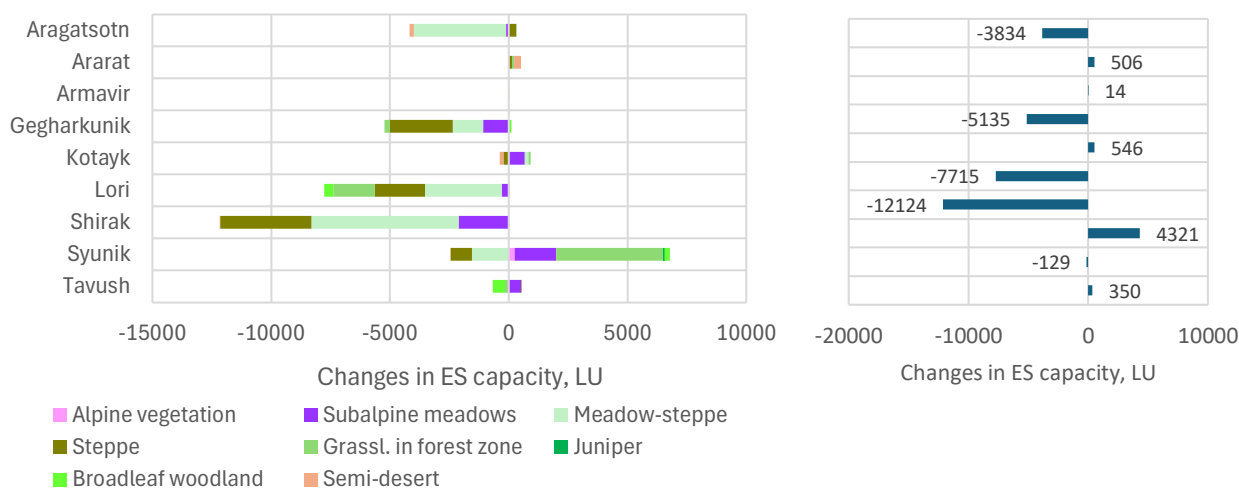

Figure 3.2.A2-2. Changes in ES capacity from 2017 to 2023 in different vegetation types across marzes

Table 3.2.A2-1. Changes in ES capacity from 2017 to 2023 in different vegetation types across marzes

	Alpine vegetation	Subalpine meadows	Meadow-steppe	Steppe	Grassl. in forest zone	Juniper	Broadleaf woodland	Semi-desert	Total
Aragatsotn	4	-100	-3887	312	25	0	0	-189	-3834
Ararat	-4	27	0	110	88	0	0	285	506
Armavir	0	0	0	0	0	0	0	14	14
Gegharkunik	26	-1074	-1273	-2649	-246	0	79	0	-5135
Kotayk	26	646	158	-233	95	0	0	-146	546
Lori	48	-282	-3251	-2103	-1758	0	-370	0	-7715
Shirak	18	-2111	-6206	-3824	0	0	0	-2	-12124
Syunik	238	1756	-1550	-902	4530	31	224	-6	4321
Tavush	0	510	0	26	-164	0	-502	0	-129
Vayots Dzor	0	-9	0	-4	359	9	-4	0	350
Total	356	-637	-16008	-9266	2930	40	-572	-44	-23202

3.2.A3. ES potential-supply-use balance

Grasslands provide forage in summer and, as hay, in winter, comprising 65–70% of total feed demand (Tovmasyan, 2020). However, an IFC/World Bank report (IFC, 2017) notes that silage and compound feeds are not widely used in Armenia, and in practice the share of concentrates is generally below the recommended 30–35%. For sheep and goats, the share of concentrates is generally lower than for cattle. For the preliminary assessment, we assumed that grasslands provide 70% of the diet for cattle and 80% of the diet for sheep and goats. We also assumed an average livestock unit (LU) coefficient of 0.75 for all the cattle of different ages and 0.14 for all sheep and goats of different age (Tovmasyan, 2015). Total number of LU adjusted for diet shares is shown in the Table 3.2.A3-1.

Table 3.2.A3-1. Livestock numbers in 2023, thousands

	Cattle			Sheep and goats			Total number of LU adjusted for diet shares
	Armstat data	LU	LU adjusted for the 70% diet share	Armstat data	LU	LU adjusted for the 80% diet share	
Aragatsotn Region	57.7	43.3	30.3	92.3	12.9	10.3	40.6
Ararat Region	38.1	28.6	20.0	106.0	14.8	11.9	31.9
Armavir Region	53.0	39.8	27.8	141.4	19.8	15.8	43.7
Gegharkunik Region	81.5	61.1	42.8	99.1	13.9	11.1	53.9
Kotayk Region	45.1	33.8	23.7	38.5	5.4	4.3	28.0
Lori Region	70.8	53.1	37.2	31.1	4.4	3.5	40.7
Shirak Region	70.1	52.6	36.8	73.7	10.3	8.3	45.1
Syunik Region	37.0	27.8	19.4	78.5	11.0	8.8	28.2
Tavush Region	29.1	21.8	15.3	18.4	2.6	2.1	17.3
Vayots Dzor Region	16.0	12.0	8.4	16.9	2.4	1.9	10.3

1226 In all marzes except Armavir the livestock numbers do not exceed the carrying capacity of grasslands, ranging from
 1227 53% in Ararat to 10% in Vayots Dzor (Table 3.2.A3-2). In Armavir marz, the livestock numbers are 6 times higher than the
 1228 carrying capacity. This figure may be explained by livestock registered in Armavir being grazed on areas classified as arable
 1229 land, kept under stall-feeding/zero-grazing, or grazed on pastures in the neighboring Aragatsotn marz. However, even if
 1230 all livestock from Armavir and Aragatsotn were evenly distributed across both marzes, their combined herd size would
 1231 exceed the combined grazing capacity of the two marzes.

1232 *Table 3.2.A3-2. The share of pasture capacity used in 2023*

	Carrying capacity of grasslands, LU (from Table 32A1-2.)	Total livestock number adjusted for diet shares, thousands of LU	Total share of pasture capacity used, %	Share of non-degraded non-woody natural areas, %	Capacity of non-degraded grasslands, thousands of LU	Share of carrying capacity used, excluding degraded lands, %
Aragatsotn	87.1	40.6	46.6	81.8	71.2	57.0
Ararat	59.7	31.9	53.4	91.2	54.4	58.6
Armavir	6.7	43.7	649.3	69.7	4.7	935.8
Gegharkunik	210.6	53.9	25.6	74.2	156.3	34.5
Kotayk	76.3	28	36.7	81.7	62.3	44.9
Lori	169.9	40.7	24	83.7	142.2	28.6
Shirak	105	45.1	43	79.7	83.7	53.9
Syunik	213.3	28.2	13.2	89.4	190.7	14.8
Tavush	74.4	17.3	23.2	59.4	44.2	39.1
Vayots Dzor	108.2	10.3	9.5	95.7	103.5	9.9
Total/average	1111.2	339.7	30.6		913.3	37.2

1233 In the above ES assessment, we do not take into account the degree of pasture degradation, which greatly reduces
 1234 the amount of ES provided. For example, according to Tovmasyan (2020), the permissible grazing rate on degraded
 1235 pastures at risk of erosion is reduced by 60% compared to pastures in good condition. Grazing should be prohibited
 1236 altogether on severely degraded pastures with a high risk of erosion. Thus, the above estimate represents an upper bound
 1237 that must be reduced to account for the degree of pasture degradation.

1238 The map of the degree of pasture degradation in Armenia was not available to us; therefore, for a preliminary
 1239 assessment we used a map of degraded lands from Armenian report for UNCCD (Government..., 2023) (Figure 3.2.A3-3
 1240 a), assuming that no grazing takes place in the areas identified there as degraded. The share of degraded non-woody
 1241 natural areas by marz was determined after excluding croplands, built-up areas, and tree cover from this map (Figure
 1242 3.2.A3-3 b).

1243 After subtracting from the total carrying capacity a portion equal to the share of degraded land in each marz, capacity
 1244 utilization in all marzes—except Armavir—did not exceed 100%, ranging from 59% in Ararat to 10% in Vayots Dzor (Table
 1245 3.2.A3-2; Figure 3.2.A3-3). In Armavir marz, the livestock numbers are 6–9 times higher than the total carrying capacity.
 1246 This indicates overuse of this ES in Armavir, if livestock are grazed on natural pastures.
 1247
 1248

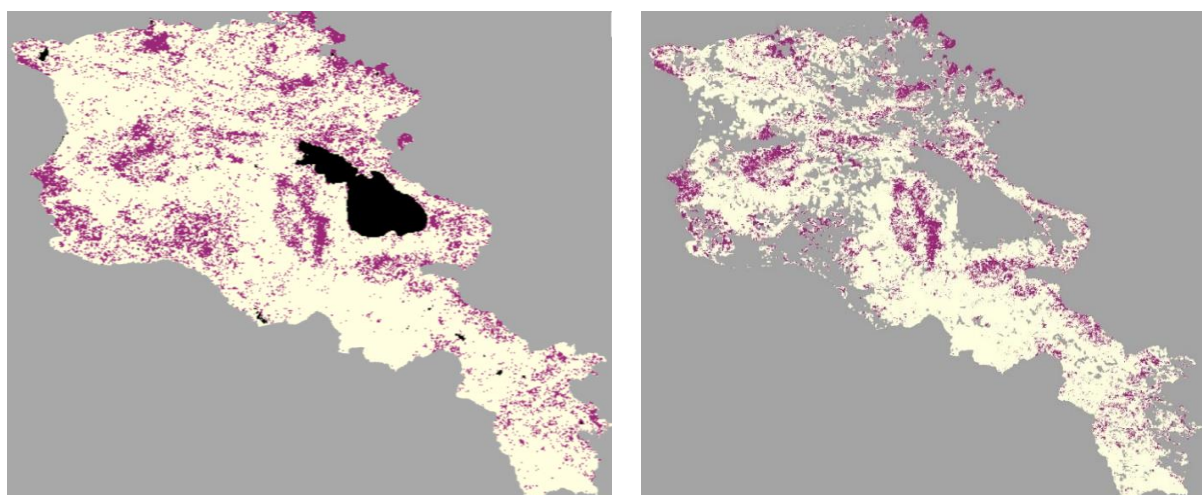

1249 *Figure 3.2.A3-3. The map of land degradation from UNCCD report (a) and the map used for this assessment with*
 1250 *croplands, built-up areas, and tree cover excluded (b)*
 1251

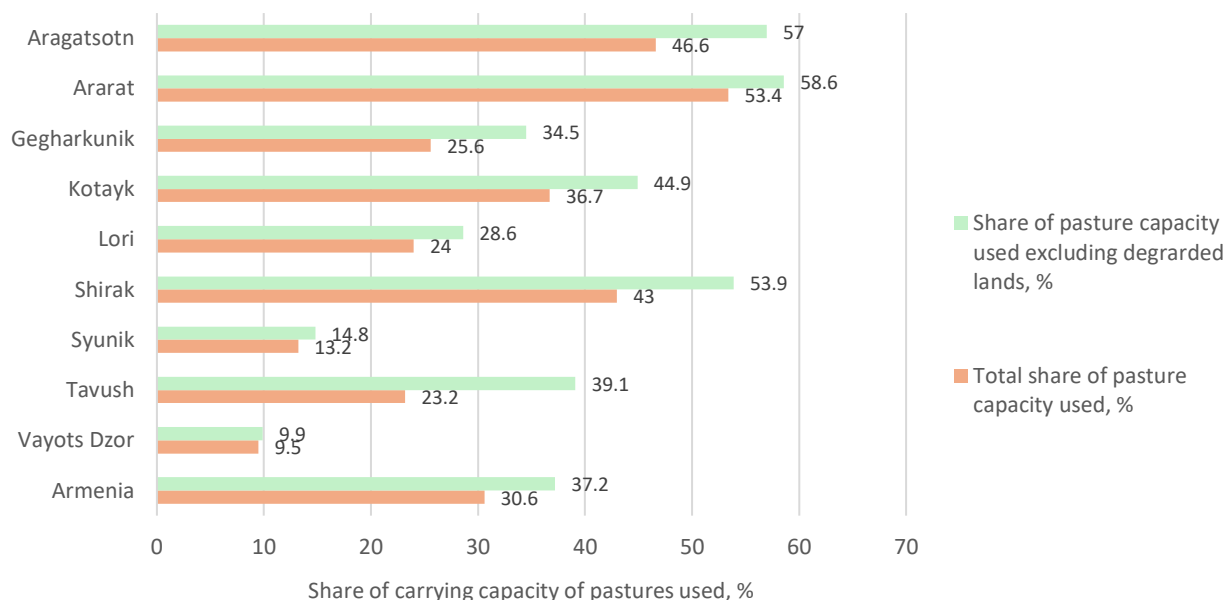

1252
1253
1254

Figure 3.2.A3-3. Share of carrying capacity of pastures used with and without taking into account pasture degradation (Armavir marz is not shown)

1255 Since we do not know how livestock is distributed across the territory, including across vegetation zones, the supply-
1256 demand table reduces into two columns in which the supplied and use values are repeated (Table 3.2.A3-3).

1257

Table 3.2.A3-3. Supply-use table

		Agriculture	Total ES supply
Aragatsotn	ES supply		40.6
	ES use	40.6	
Ararat	ES supply		31.9
	ES use	31.9	
Armavir	ES supply		6.73
	ES use	6.73*	
Gegharkunik	ES supply		53.9
	ES use	53.9	
Kotayk	ES supply		28
	ES use	28	
Lori	ES supply		40.7
	ES use	40.7	
Shirak	ES supply		45.1
	ES use	45.1	
Syunik	ES supply		28.2
	ES use	28.2	
Tavush	ES supply		17.3
	ES use	17.3	
Vayots Dzor	ES supply		10.3
	ES use	10.3	
Armenia	ES supply		339.7
	ES use	339.7	

1258

1259

1260

3.2.B. Wild plants used by humans

1261

In this section we assess three types of benefits to people from the use of wild plants: edible and culinary species, medicinal species, and the production of nectar by wild plants for honey production. The assessments of the provided ES are given in score based on the known number of species in the corresponding plant groups. In the future, these assessments should be refined using data on productivity and permissible levels of plant harvesting from the wild.

1262

1263

3.2.B1. Edible and culinary plants

1264

The wild flora of Armenia includes around 3,800 species of vascular plants, which accounts for more than half of the entire flora of the Caucasus. Many plant species have been used as food by the local population since ancient times. For this study, we selected species that are widely used both across Armenia and in specific regions. In the vast majority of cases, people collect these plants in natural ecosystems for personal use in households. They are more rarely sold in markets at small quantities, and large-scale commercial harvesting is practically absent.

1265

Our review includes 75 species used as vegetables (in fresh or home-cooked form), 27 species of fruit, berry, and nut-bearing plants (used fresh, or in the form of juices, compotes, etc.), 9 species of aromatic herbs typically used as flavoring for dishes or beverages, 5 species used in alcoholic beverage production, and 17 species used in the preparation of non-alcoholic drinks. These species are found in various altitudinal zones and natural ecosystems (Figure 3.2.B1-1, Table 3.2.B1-1, Appendix 3.2.B-1). The highest number of edible plant species is found in forest and steppe ecosystems, primarily within the mid-mountain belt. Slightly fewer species grow in broadleaf woodlands, meadow-steppes, and subalpine meadows. Edible plants are virtually absent in desert ecosystems and are very scarce in the alpine zone. Figure 3.2.B1-2 shows the uneven spatial distribution of species richness of culinary and edible plants.

1266

1267

1268

1269

1270

1271

1272

1273

1274

1275

1276

1277

1278

1279

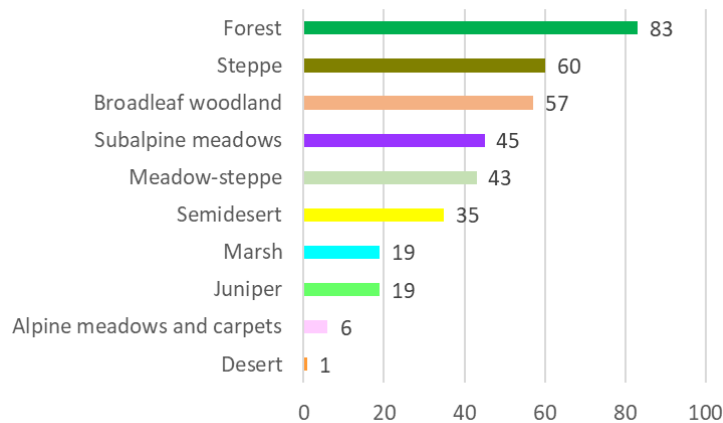

1280

Figure 3.2.B1-1. The number of edible and culinary plant species characteristic of different types of natural vegetation

1281

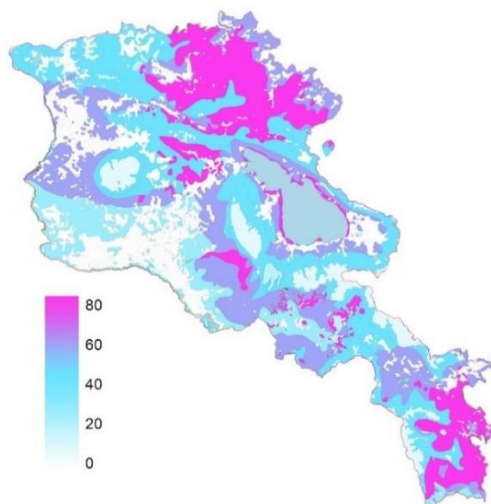

1282

Figure 3.2.B2-2. Map of the ES provided by natural vegetation, assessed by the total number of edible plant species

1283

1284

Table 3.2.B1-1. The number of edible and culinary plant species occurring in different ecosystem types

	Vegetable plants	Fruit-berry and nuts	Spicy plants	Used in alcohol drinks	Used in non-alcohol drinks	Total
Alpine vegetation	5	-	1	-	-	6
Broadleaf woodland	28	13	4	2	10	57
Desert	1	-	-	-	-	1
Forest	38	25	3	5	12	83
Juniper	12	1	4	-	2	19
Marsh	13	2	1	-	3	19
Meadow-steppe	27	5	3	-	8	43
Semidesert	28	2	3	-	2	35
Steppe	41	5	5	1	8	60
Subalpine meadows	27	7	2	1	8	45

1285

1286

1287

1288

1289

1290

1291

1292

1293

1294

1295

1296

1297

1298

1299

1300

Most edible plants are common in Armenia (taking into account the distribution of different ecosystems across the various regions of the country). The only species included in the Red Data Book of Plants of Armenia is *Gundelia hajastana* (listed in the Red Book as *Gundelia rosea*). This species was widely used as a food plant in the Kotayk Province (where its main range is located) until the 1950s. It was then largely forgotten and is now rarely gathered or used.

Edible plants in Armenia are collected primarily by the local rural population for personal use and in very small quantities for sale at urban markets. At the current level of use, wild populations of most species remain stable. Only a few species are collected in relatively large quantities for export. For example, several years ago, licorice (*Glycyrrhiza glabra*) was harvested for export to Georgia for the production of non-alcoholic beverages; however, even in that case, it was collected from abandoned agricultural fields where it was naturally spreading intensively.

Nevertheless, if large-scale commercial harvesting were to begin, many species could face the risk of overexploitation. Unfortunately, while some studies on wild plant resources were conducted during the Soviet period, in the past 30 years such research has been almost entirely lacking, and there is no available data on the current or potentially usable reserves of these plants.

3.2.B2. Medicinal plants of Armenia

1301

1302

1303

1304

1305

1306

1307

1308

1309

1310

1311

1312

1313

Armenia is home to a very large number of medicinal plant species. Only a small number of them are included in the official pharmacopoeia, while the vast majority are used in traditional medicine. The medicinal properties of plants native to Armenia have been known since ancient times. As early as the Middle Ages, Armenian scholars wrote specialized treatises on medicinal plants (Harutyunyan, 1990). During the Soviet period, the Institute of Fine Organic Chemistry of the Armenian Academy of Sciences had a department dedicated specifically to studying the medicinal properties of wild plants in Armenia. Today, people mostly rely on pharmaceutical industry products, but at the same time, there is a growing trend toward the use of natural products, including medicinal plants.

From the vast diversity of medicinal plants in Armenia, we selected 155 species for analysis — those that are most widespread and most commonly used in traditional medicine. These species are found across various elevation zones and natural ecosystems (Figure 3.2.B2-3, Table 3.2.B2-2, Appendix 3.2.B2). The highest number of medicinal plant species is concentrated in the middle and upper mountain belts, primarily in forests, steppes, meadow-steppes, open woodlands, and subalpine meadows. Figure 3.2.B-4 shows the uneven spatial distribution of species richness of culinary and edible plants.

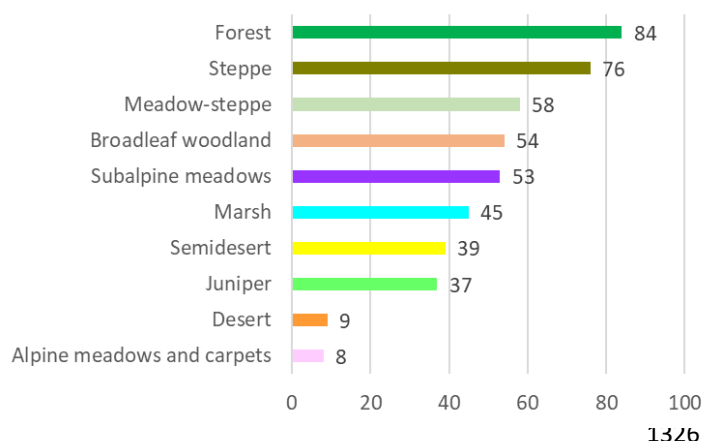

Figure 3.2.B2-3. The number of medicinal plant species characteristic of different types of natural vegetation

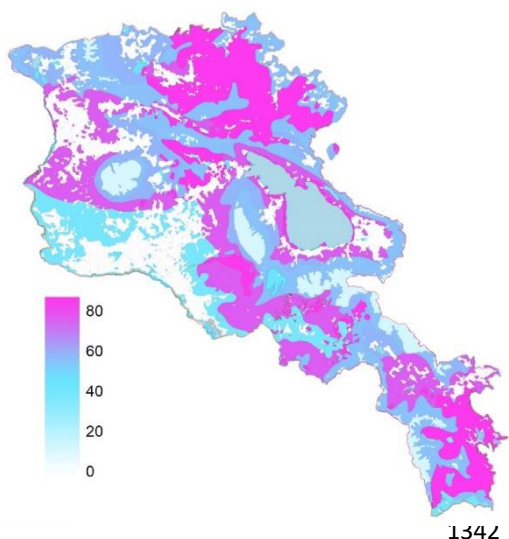

Figure 3.2.B2-4. Map of the ES provided by natural vegetation, assessed by the total number of medicinal plant species

1343 Table 3.2.B2-2. The number of medicinal plant species characteristic of different types of natural vegetation

Type of vegetation	Species number
Alpine meadows and carpets	8
Broadleaf woodland	54
Desert	9
Forest	84
Juniper	37
Marsh	45
Meadow-steppe	58
Semidesert	39
Steppe	76
Subalpine meadows	53

1344
 1345 Most populations of medicinal plants are found throughout Armenia within their respective natural ecosystems. They
 1346 are generally abundant, and the current level of harvesting does not pose a threat of overexploitation. However, a
 1347 number of species are rare and included in the Red Data Book of Plants of Armenia (Tamanyan et al., 2010) (Table 3.2.B2-
 1348 3). Most of the species presented in our study are either not used at all today or are used in minimal quantities for
 1349 personal household needs. Only a very small amount is sold in markets or on the streets of cities. Unfortunately, no
 1350 research is currently being conducted in Armenia to assess the wild reserves of medicinal plants or the potential for their
 1351 sustainable use.

1352 Table 3.2.B2-3. Medicinal plants included in the Red Data Book of Plants of Armenia

Species	Category in the Red Book	Comments
<i>Acorus calamus</i>	Endangered (EN)	Grows only in Armavir and Ararat marzes
<i>Atropa bella-donna</i>	Vulnerable (VU)	-
<i>Calendula persica</i>	Endangered (EN)	Grows only in Syuniqu marz
<i>Cocciganthe flos cuculi</i>	Critically Endangered (CR)	Only one population is known in Lori marz
<i>Cyclamen vernal</i>	Vulnerable (VU)	Grows only in the North of Tavush marz
<i>Halostachys belangeriana</i>	Endangered (EN)	Has small area of occurrence, grows on salt bodies (solonchaks) in Armavir and Ararat marzes
<i>Menyanthes trifoliata</i>	Vulnerable (VU)	Usually, size of populations is very small
<i>Nuphar lutea</i>	Critically Endangered (CR)	Very rare species, only one population is known in the North of Shirak marz
<i>Nymphaea alba</i>	Endangered	Rare species, the main area of distribution lies in Lori marz
<i>Paeonia tenuifolia</i>	Critically Endangered (CR)	Very rare species, only one small population is known in Syuniqu marz
<i>Potentilla erecta</i>	Critically Endangered (CR)	Only a few small populations are known in the North of Armenia
<i>Sphaerophysa salsula</i>	Vulnerable (VU)	Rare species, only one population was known, but in the last years some new small populations were found in Ararat marz

1353

1354 **3.2.B3. Nectar production by natural vegetation**

1355 In the strict narrow sense, the ES of wild honey production refers specifically to honey collected from wild bees.
 1356 However, this practice is currently rare in Armenia. Most honey in Armenia is produced through conventional beekeeping
 1357 using domesticated honeybees (*Apis mellifera*). Even so, much of this honey is still derived from natural vegetation. In
 1358 this case, natural ecosystems produce nectar, which is then processed into honey by domesticated bees. At this stage,
 1359 for a preliminary assessment of the potential supply of the ES, we used the number of honey plant species across different
 1360 types of natural vegetation in Armenia. Clearly, this estimate should be refined in the future using data on the abundance
 1361 and productivity of honey plants. The used ES can be considered as honey production for human consumption. However,
 1362 since we do not have such statistical data, the used ES was not assessed.

1363 Honey plants are those that produce large amounts of nectar and/or pollen. According to A.A. Grossheim (1952), all
 1364 honey plants can be divided into two groups: primary and secondary. Primary honey plants are those that produce
 1365 significant quantities of nectar and pollen accessible to bees and are, in most cases, characterized by a long flowering
 1366 period. A limited flowering period is not always a disadvantage for honey plants. For example, plants that bloom in early
 1367 spring—although for a relatively short time—are important seasonal sources of nectar. Secondary honey plants are of
 1368 lesser value but still contribute to the overall nectar potential of an area. Their presence in the vegetation increases the
 1369 usefulness of the land from the perspective of beekeeping.

1370 In Armenia, nearly half of all flowering plant species—over 1,400 species—are considered honey plants, either
 1371 primary or secondary (Muradyan, 2019). We analyzed only primary honey plants, as their abundance and diversity largely
 1372 determine the value of ecosystems in terms of the ecosystem service of wild honey provision. When assessing the
 1373 importance of plant species for this ES, in addition to the flowering period, it is also necessary to consider their
 1374 representation across various ecosystems, elevation zones, and ecological amplitude. The broader and more widespread
 1375 these characteristics are, the more valuable the species is as a honey plant.

1376 We identified 238 species of primary honey flowering plants from 47 families and 117 genera. These species are
 1377 distributed very unevenly across the main vegetation types of Armenia (Figure 3.2.B3-5, Table 3.2.B3-4, Appendix 3.2.B3).

1378 The great diversity of honey plants is found in the mid-mountain zone—from the middle to subalpine mountain belts
 1379 (steppe, meadow steppe, and subalpine zones), where natural ecosystems occupy the largest areas. However, the
 1380 relatively low number of honey plant species in the alpine belt should not be underestimated: almost all of them are
 1381 dominant species in alpine meadows and cover the largest areas there. Moreover, their mass flowering occurs in the
 1382 second half of summer, when most honey plants in the lower belts have already finished blooming. Semi-deserts should
 1383 also be considered valuable honey-producing ecosystems, despite the relatively low number of melliferous plant species.
 1384 This is because their flowering period occurs mainly in spring—when ecosystems at higher elevations have not yet begun
 1385 to bloom. It should also be noted that the main fruit orchards, which are among the most important honey resources,
 1386 are located in this zone. However, our analysis does not include cultivated plants. For desert zone, we identified only two
 1387 honey plant species. Given the very limited area of true deserts in Armenia, their value as honey-producing ecosystems
 1388 is minimal. Marsh ecosystems, represented by waterlogged habitats along the shores of water bodies, also have low
 1389 value as honey-producing areas. Forest ecosystems are mainly characterized by spring-flowering and wind-pollinated
 1390 species, which produce large amounts of pollen. Figure 3.2.B-6 shows the uneven spatial distribution of species richness
 1391 of culinary and edible plants.

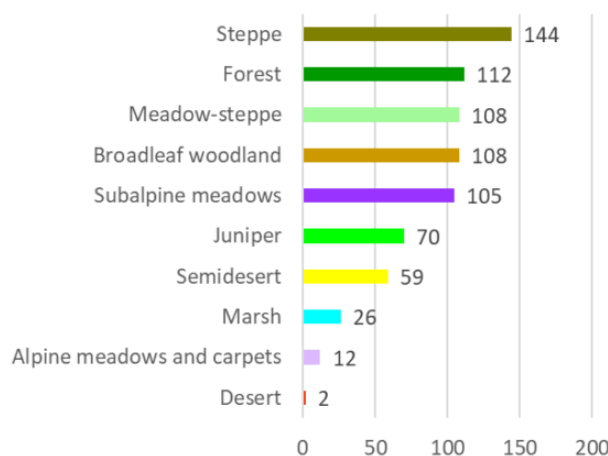

1392
 1393 *Figure 3.2.B3-5. Number of honey plant species in the main vegetation types*

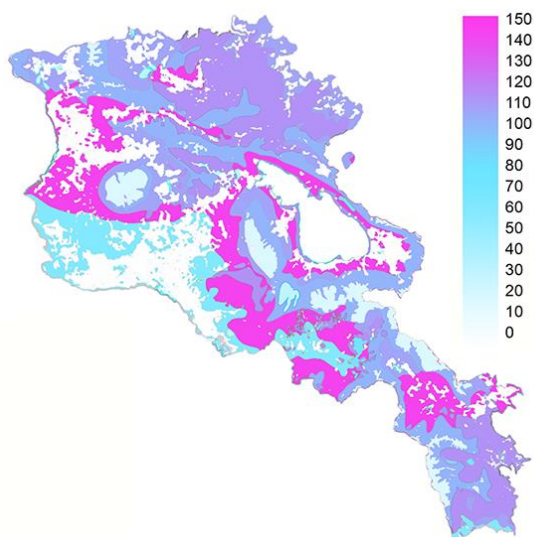

Figure 3.2.B3-6. Map of the ES provided by natural vegetation, assessed by the number of honey plant species

Table 3.2.B3-4. Number of honey plant species in the main vegetation types

Vegetation type	Number of honey plant species
Alpine meadows and carpets	12
Broadleaf woodland	108
Desert	2
Forest	112
Juniper	70
Marsh	26
Meadow-steppe	108
Semidesert	59
Steppe	144
Subalpine meadows	105

3.2.B4. Aggregate assessment of the ES provided by human-used plants

The total ES was calculated by adding together the scores for the three plant groups: culinary, medicinal, and honey plants. The scores were normalized within each group (to the maximum value) and expressed as percentages (Table 32B4-5). Overall, ES is provided to the greatest extent by forest and steppe ecosystems, and to the least extent by desert and alpine ecosystems (Figures 32B4-7, 32B4-8). This pattern is very similar across all three plant groups.

Table 3.2.B-5. Species number and score (normalized to the maximum value, %) of three groups of human-used plants in vegetation zones of Armenia

Type of vegetation	Medicinal plants		Edible plants		Honey plants		Total	
	Species number	Score	Species number	Score	Species number	Score	Species number	Summed score
Alpine meadows and carpets	8	10	6	7	12	8	26	25
Broadleaf woodland	54	64	57	69	108	75	219	208
Desert	9	11	1	1	2	1	12	13
Forest	84	100	83	100	112	78	279	278
Juniper	37	44	19	23	70	49	126	116
Marsh	45	54	19	23	26	18	90	95
Meadow-steppe	58	69	43	52	108	75	209	196
Semi-desert	39	46	35	42	59	41	133	130
Steppe	76	90	60	72	144	100	280	263
Subalpine meadows	53	63	45	54	105	73	203	190

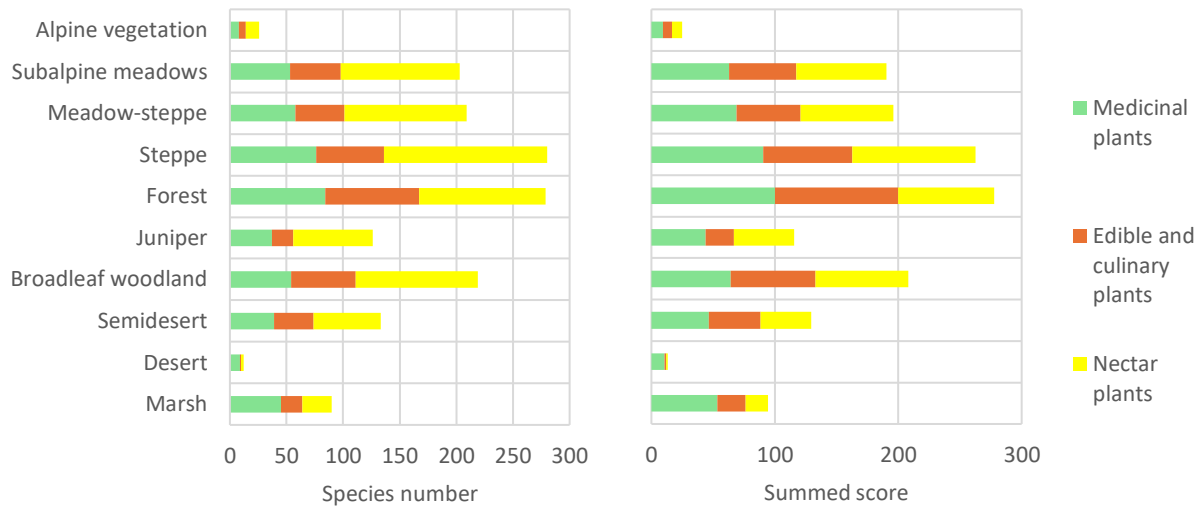

Figure 3.2.B4-7. Species number and summed ES scores across vegetation zones

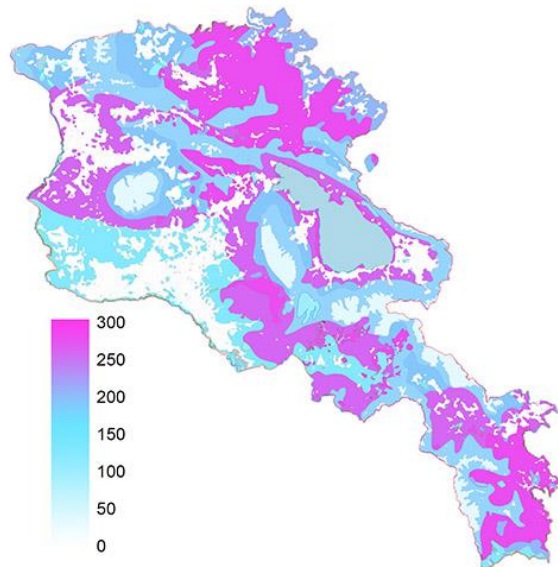

Figure 3.2.B4-8. The map of ES summed score

1406
1407

1408
1409

1410

ES potential of different ecosystem types across marzes was assessed by multiplying the total scores of vegetation types (Table 3.2.B-5) by the area of each vegetation zone in each marz (Section 2.3.D). The largest ES potential is found in marzes that have extensive areas of forest and steppe zones (Syunik, Lori, Tavush). The high ES value in the Gegharkunik marz is due to the large area of subalpine meadows, which, along with forests and steppes, also host a considerable number of useful plant species. The lowest level of ES provision is observed in Armavir marz due to the small area of remaining natural ecosystems which are almost entirely semi-deserts with a relatively low number of useful plant species (Figure 3.2.B-9). Figure 3.2.B-10 shows the share of ES provision contributed by different vegetation types in various marzes. In Tavush marz, the overwhelming majority of the ES is provided by forests and woodlands, while in Shirak and Aragatsotn marzes it is delivered mainly by typical and meadow steppes.

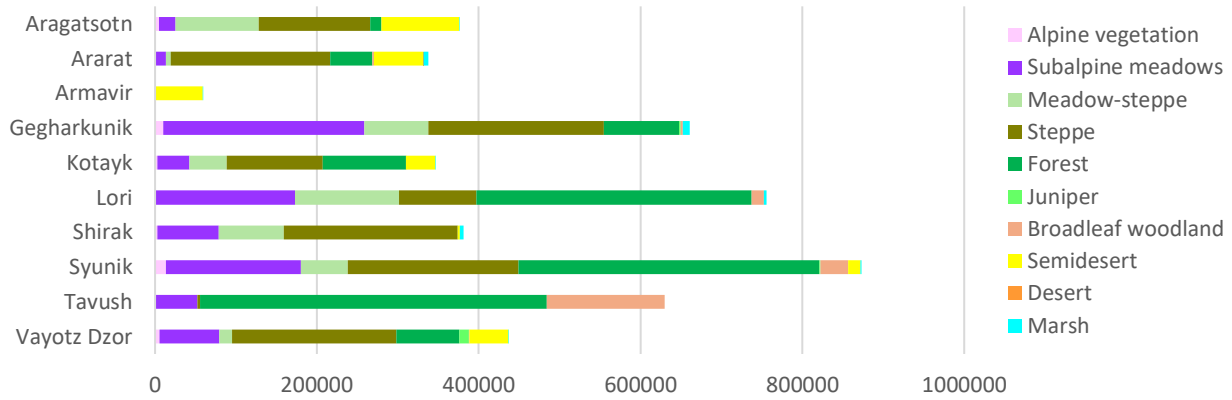

1420

1421

Figure 3.2.B4-9. ES provision by ecosystems within marzes (summed scores)

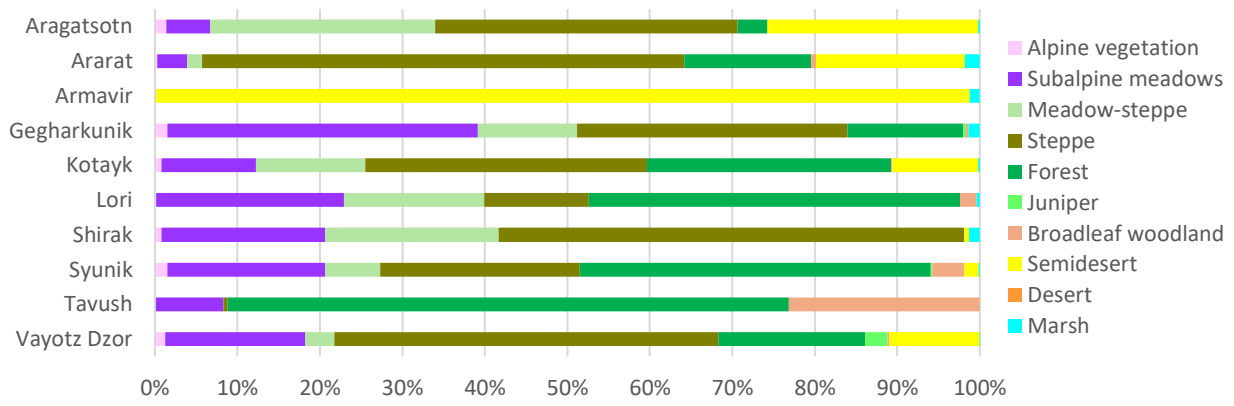

1422

1423

Figure 3.2.B4-10. The share of ES provided by different vegetation types within marzes (%)

1424

1425

1426

1427

According to the applied scoring method for assessing ES provided by different vegetation types, the changes in ES across marzes differ from changes in the area of various vegetation types (Section 2.3.D) being multiplied by their corresponding total ES scores (Figure 3.2.B-11).

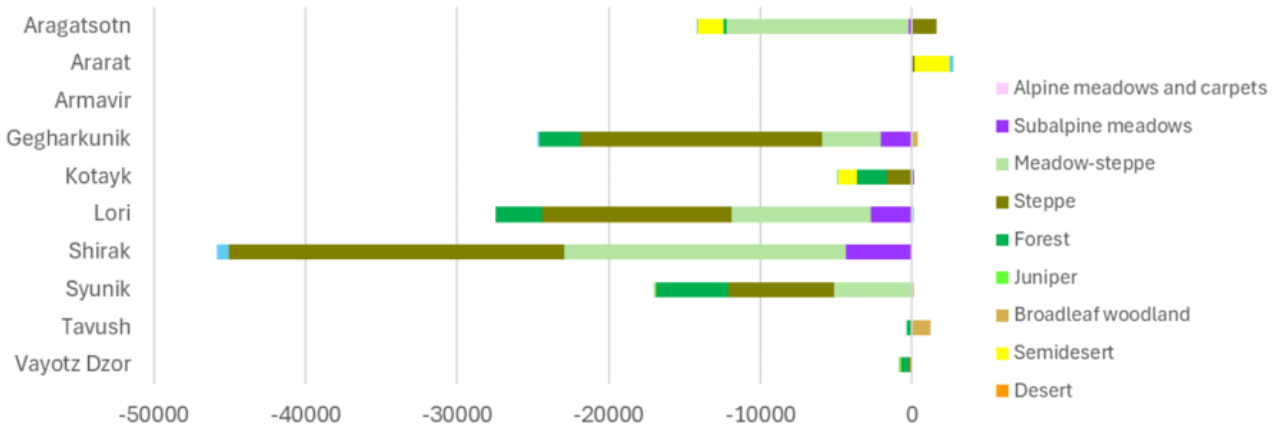

1428

1429

Figure 3.2.B4-11. Changes in ES provision by ecosystems within marzes (summed scores)

3.3. Recreational ES: maximum permissible recreational load

3.3.A. General approach to assess ES capacity

Recreation is a multifaceted interaction between humans and nature. Different forms of recreation require different conditions and have different impacts on the environment. This assessment considers only one rather narrow aspect of this phenomenon — hiking and off-trail recreation in terrestrial ecosystems.

Although recreation has in recent years been classified as a cultural ecosystem service, many of the factors that determine the quality of this service are quite material in nature (such as water and air quality, and the condition of natural ecosystems). The impacts of unregulated and excessive recreation are also largely material, leading to trampling, ecosystem degradation, disturbance of wildlife, deterioration of water quality, and other effects. Therefore, in this assessment, recreation is considered as the material use of ecosystems by humans, in which the level of ES use should not exceed the capacity of ecosystems to provide this service.

The ES of providing natural conditions for recreation is understood here as ensuring that people have the opportunity to be in a non-degraded natural environment. Based on this, the ES potential/capacity is determined by the maximum permissible recreational load, which indicates the maximum number of recreationists that does not yet lead to recreational digression of ecosystems. Actual recreational load is considered as indicator of ES use. When ES use exceeds the capacity of ecosystems to provide it, depletion of the ES occurs. Thus, when the permissible recreational load is exceeded, ecosystem degradation begins, and they lose the qualities for which people seek out nature.

There are two main experimental approaches to determining the maximum permissible recreational load: 1) the maximum number of passes over the surface that does not lead to noticeable changes in vegetation and soil, or leads to a level of change that is considered acceptable for the given area or route; 2) the maximum permissible density of visitors in different ecosystem types that does not lead to recreational degradation, or leads to a degree of recreational degradation that is considered acceptable for the given area.

Experimentally, it has been established that several dozen or hundred passes over the same spot lead to degradation of vegetation and soil, resulting in the formation of a trail. In alpine and subalpine ecosystems, 50% of vegetation cover is lost after 100–500 passes, with herbfields being less resistant than grasslands; for the understory of mountain broadleaf forests, this threshold is 70–270 passes (Godefroid & Koedam, 2004; Hill & Pickering, 2009; Piscová et al., 2021; Yuejin et al., 2022). An important point for recreation assessment is that the relationship between the degree of vegetation and soil degradation and the number of passes is nonlinear: most degradation occurs under low to moderate use, after which further intensification of use on an already formed trail becomes less significant, provided that no lateral trails are created (Bernhardt-Römermann et al., 2011; Marion et al., 2016; Piscová et al., 2021). However, applying these data to estimate the maximum permissible number of visitors is difficult because we do not know exactly how people move across natural areas. This method is also unsuitable for assessing the carrying capacity of already established tourist trails and routes, as a trail or even an unpaved road already exists there.

Therefore, we applied the second approach—namely, the assessment of the ES potential/capacity, i.e. maximum permissible density and number of visitors in areas of natural ecosystems adjacent to roads and the Transcaucasian Trail. We did not assess service use, as the actual number of recreationists and their spatial distribution across the area are unknown to us.

As a map of current ecosystems, we used the vegetation map created within the project (Section 2.3), combined with the tree, crops, and built-up classes from the Esri 2023 land cover (Fig. 3.3.A-1).

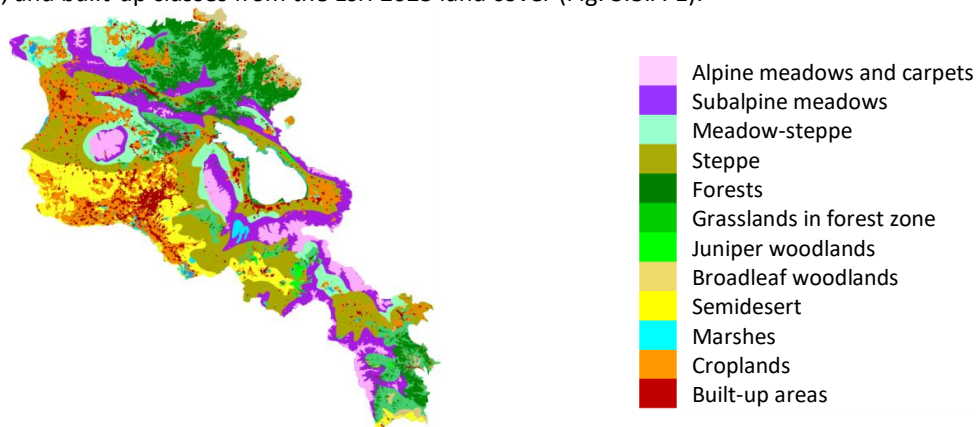

Figure 3.3.A-1. Actual terrestrial ecosystems of Armenia

1472 The maximum permissible recreational load for terrestrial ecosystems of Armenia was calculated based on a
 1473 methodology developed by Soviet scientists and approved by the USSR State Committee for Forestry [Temporary
 1474 methodology..., 1988]. This methodology does not directly include the ecosystems of Armenia; however, it contains
 1475 indicators for steppes, meadows, and bogs of different types in Russia and Ukraine, as well as for mountain forests of the
 1476 Caucasus using Georgia as an example. On the basis of these data, we determined the following values of the maximum
 1477 permissible recreational load for natural ecosystems of Armenia for planned and tourism (Table 33A-1). The estimates
 1478 were done for four kinds of recreation:

- 1479 - Excursions: people follow a designated trail with a guide, without campfires or overnight stays.
- 1480 - Managed tourism: multi-day hike with overnight stays along an equipped route, where designated areas for
 1481 campfires and tents are available.
- 1482 - Self-organized tourism: multi-day hikes along any chosen routes with overnight stays and campfires.
- 1483 - Mass daily recreation: no overnight stays, but activities may include barbecues, games, and other leisure activities

1484 *Table 33A-1. Average annual maximum allowable simultaneous recreational load (persons/ha)*

	<i>Excursions</i>	<i>Managed tourism</i>	<i>Self-organized tourism</i>	<i>Mass daily recreation</i>	<i>Corresponding vegetation types from the Temporary methodology (1988)</i>
Alpine meadows and carpets	1.2	0.45	0.2	0.3	Averaged value for: lichen, sphagnum, herb-sphagnum, herb-bog pine and birch forests; wet floodplain and lowland meadows
Subalpine meadows	6.0	2.0	0.9	1.5	Wet floodplain and lowland meadows. Fresh upland meadows and steppes
Meadow-steppe	4.6	1.5	0.7	1.15	Averaged value for: dry floodplain, lowland, and upland meadows and steppes; wet floodplain and lowland meadows, fresh upland meadows and steppes
Steppe	3.2	1.1	0.5	0.8	Dry meadows and steppes
Forests	1.2	0.4	0.2	0.3	Averaged value for forests in the territory of the former Central Transcaucasian and Upper Kartli regions of the Georgian SSR
Grasslands in forest zone	3.2	1.1	0.5	0.8	Dry meadows and steppes
Broadleaf woodlands	0.8	0.3	0.1	0.2	Dry pine forests, very dry oak forests
Juniper woodlands	0.9	0.3	0.1	0.2	Dry juniper woodlands
Semidesert	1.6	0.5	0.2	0.4	Very dry upland meadows and steppes
Marshes	1.2	0.45	0.2	0.3	Averaged value for: herb-bog and bog tall-herb pine and birch forests; wet floodplain and lowland meadows

1485

1486 **3.3.B. Maximum permissible number of recreationists for daily weekend recreation in roadside-accessible**
 1487 **zones**

1488 Estimates of permissible recreational load directly depend on the spatial distribution of recreationists across natural
 1489 ecosystems: seasonal and daily activity, the areas where they mainly concentrate, how far they travel from roads,
 1490 settlements, and tourist centers, and the extent to which they deviate from established tourist routes and trails.

1491 An important factor in the spatial distribution of recreationists is landscape accessibility. Data from OpenStreetMap
 1492 (OSM)³² show that informal tracks (farm tracks, forest and field access roads, service paths, seasonal routes, foot-access
 1493 paths) cover almost the entire territory of Armenia, with the exception of some mountainous and semi-desert areas (red
 1494 in Figure 3.3.B-1). The nature of these tracks varies, and the data require careful verification. Nevertheless, they indicate
 1495 that the vast majority of Armenia is potentially accessible to people, which should be taken into account when planning
 1496 biodiversity conservation measures.

1497 Since data on informal tracks provide only a preliminary general impression of the potential accessibility of the
 1498 territory and require verification, we used the network of formal roads (black in Figure 3.3.B-1), which includes the
 1499 following categories: motorway and trunk (major high-speed roads and national roads connecting major cities and
 1500 regions); primary roads (main regional roads linking large settlements); secondary (smaller regional roads connecting
 1501 towns and rural areas); tertiary (local roads providing access between villages and minor settlements).

1502 Collecting data on the actual spatial and temporal distribution of recreationists is a major task, and at this stage we
 1503 did not have access to such data. Therefore, all estimates presented below are methodological examples intended to
 1504 demonstrate how an assessment of the recreational carrying capacity of ecosystems could be conducted if data on the
 1505 spatial and temporal distribution of recreationists were available.

³² <https://download.geofabrik.de/asia/armenia.html>

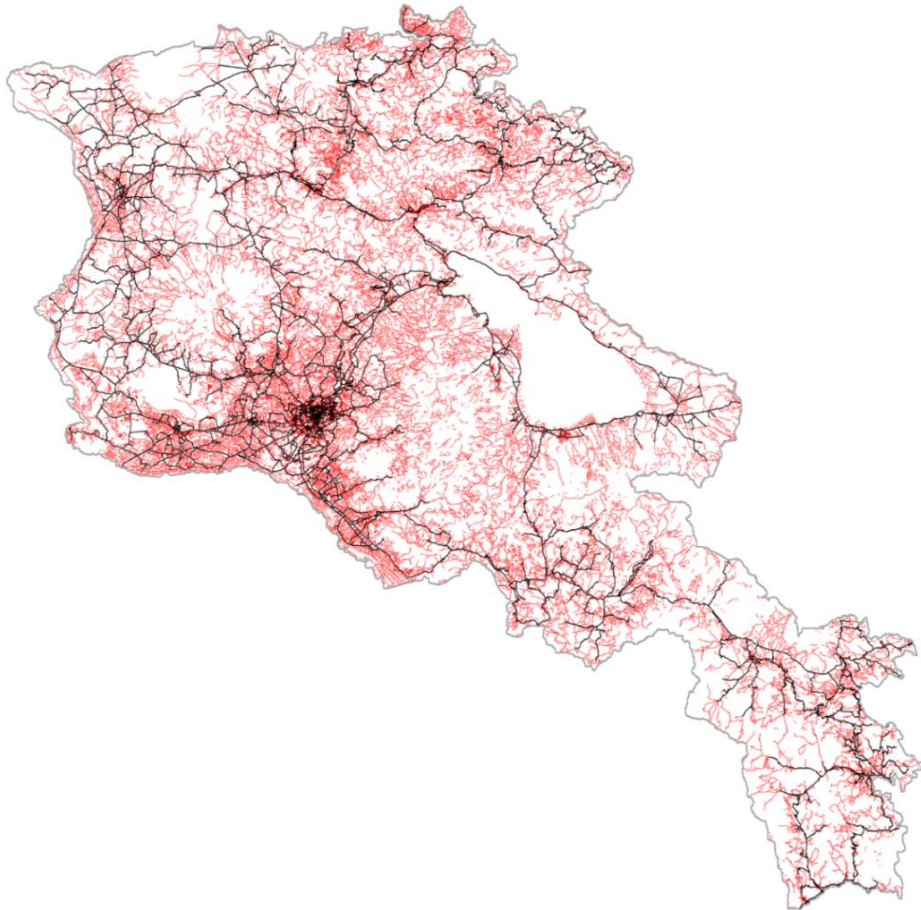

1506

1507

1508

Figure 3.3.B-1. Accessibility of the territory of Armenia based on OSM data. Formal roads are shown in black, and informal tracks in red.

1509

1510

1511

1512

1513

1514

1515

To determine the maximum permissible number of recreationists, it is necessary to know the area they occupy and the duration of their stay. The assumption of their uniform year-round distribution across the entire area of ecosystems appears completely unrealistic; therefore, as a methodological example, we assessed this indicator over a period of 6 months in zones located 0.5 and 2 km away from roads and settlements. Car roads were sourced from OpenStreetMap³³ and built-up areas were extracted from the Esri 2023 land cover data. 500 m and 2000 m buffers around roads and settlements were constructed, and the area of each ecosystem type within these buffers was calculated (Figure 3.3.B-2).

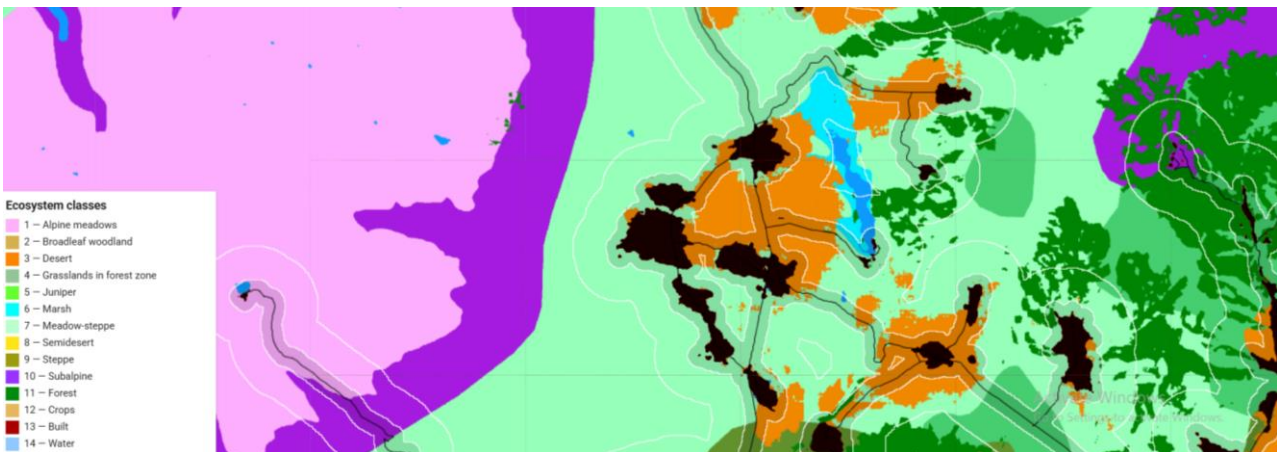

1516

1517

1518

Figure 3.3.B-2. Map fragment showing 0.5 km and 2 km accessibility zones around roads to the east of Mount Aragats. For details see project Web GIS <https://bccarmenia.nextgis.com/>, section "Ecosystem services. Recreation"

³³ <https://download.geofabrik.de/asia/armenia.html>

1519 Within the 500 m accessibility zone from roads, croplands occupy nearly one third of the area, while in the 2 km zone
 1520 they account for 21%. Among natural ecosystems, steppe and semi-desert ecosystems cover the largest area. Forests
 1521 make up 8.8% in the 500 m zone and 12.2% in the 2 km zone. Alpine meadows, juniper woodlands, and marshes are
 1522 extremely scarce within these accessibility zones (Figure 3.3.B-3; Table 3.3.B-1).

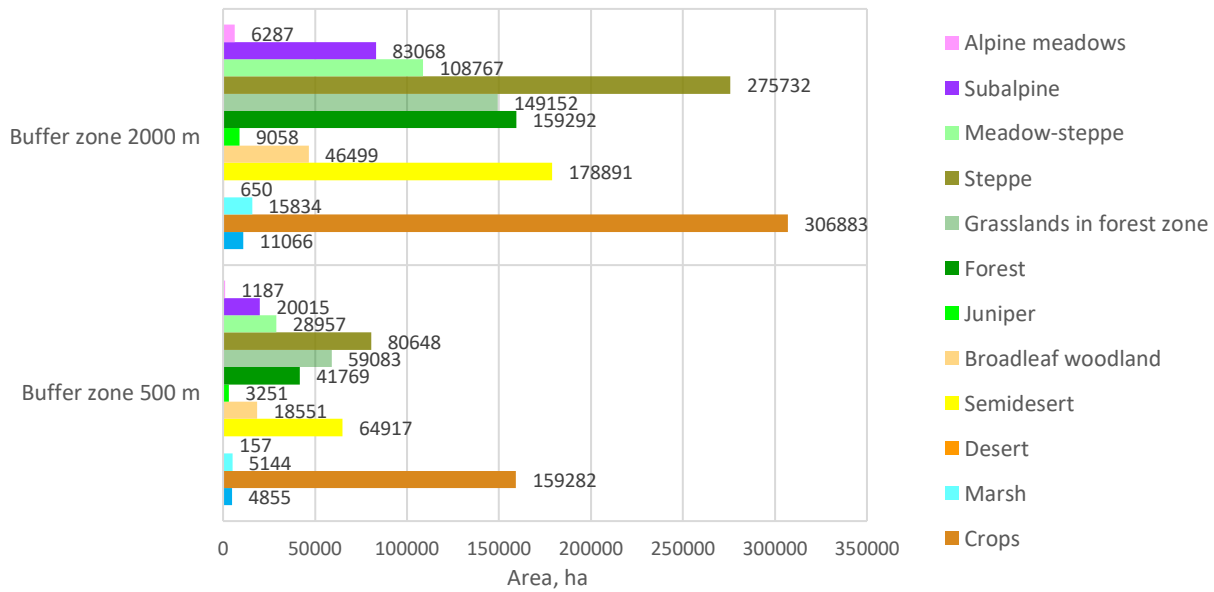

1523

1524 *Figure 3.3.B-3. Area of different ecosystem types within the 0.5 km and 2 km recreational accessibility zones*

1525 However, the small area of a particular ecosystem type within an accessibility zone does not mean that these
 1526 ecosystems are free from the threat of recreational degradation. In the most accessible 500 m zone, about a quarter of
 1527 the total area of juniper, broadleaved woodlands, semi-desert, desert, and marshes are located. Within the 2 km
 1528 accessibility zone, 70–80% of these ecosystems are found, including almost all remaining desert area (Figure 3.3.B-4).

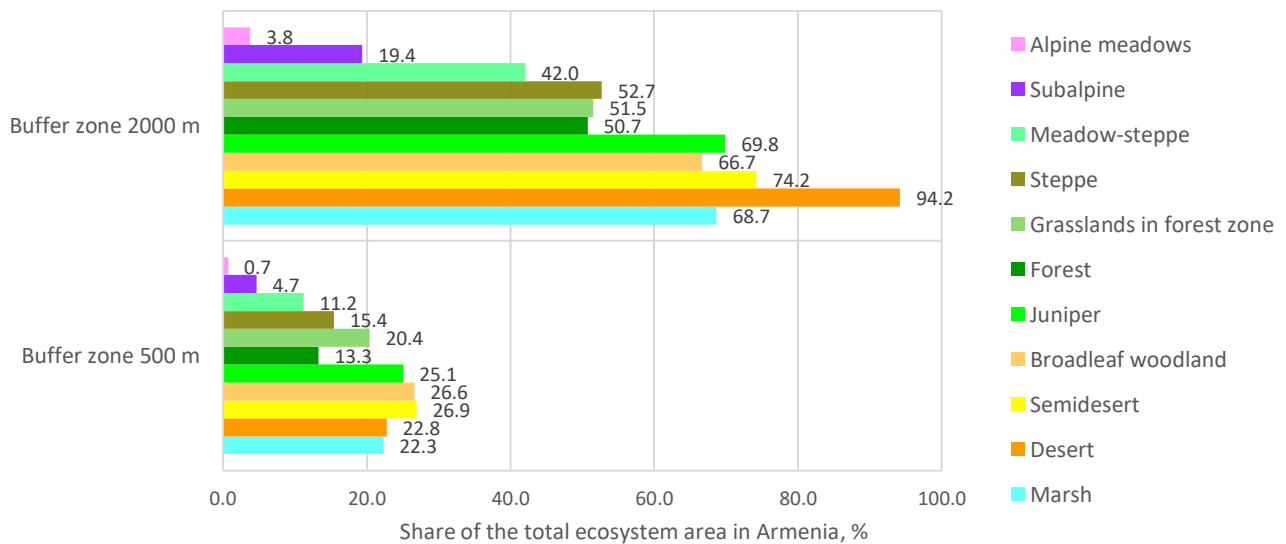

1529

1530 *Figure 3.3.B-4. Share of the total ecosystem area in Armenia located within recreational accessibility zones, %*

1531 In accordance with the Temporary Methodology (1988), the permissible average seasonal one-time recreational load
 1532 is determined as

$$R_s = R_y(T_y/T_s) \tag{3.3.B-1}$$

1533 where R_y is the permissible average annual one-time recreational load indicated in Table 33B-1, $T_y = 8760$ hours per
 1534 year, and T_s is the number of hours in the recreational season, which in our example amounts to 624 hours (12 hours ×
 1535 52 weekend days). Thus, the permissible average seasonal load is $R_s = 14 R_y$ (Table 3.3.B-2). It is important to emphasize
 1536 that with an increase in the time recreationists spend in nature — for example, under year-round recreation — their
 1537 maximum permissible number will not increase but decrease, as longer presence leads to greater pressure on
 1538 ecosystems.
 1539

1540

Table 3.3.B-1. Area of different ecosystem types within the 0.5 km and 2 km recreational accessibility zones

	Accessibility zone 500 m			Accessibility zone zone 2000 m			Total ecosystem area in Armenia, ha
	Area, ha	Share of the zone area, %	Share of the total ecosystem area in Armenia, %	Area, ha	Share of the zone area, %	Share of the total ecosystem area in Armenia, %	
Alpine vegetation	1187.2	0.2	0.7	6287.1	0.4	3.8	165410
Subalpine meadows	20015.0	3.6	4.7	83068.4	5.6	19.4	428760
Meadow-steppe	28957.4	5.3	11.2	108766.7	7.4	42.0	258730
Steppe	80647.8	14.7	15.4	275732.1	18.7	52.7	523250
Grasslands in forest zone	59082.9	10.7	20.4	149152.3	10.1	51.5	289690
Forest	41769.2	7.6	13.3	159291.7	10.8	50.7	314030
Juniper	3251.2	0.6	25.1	9058.5	0.6	69.8	12970
Broadleaf woodland	18550.9	3.4	26.6	46499.3	3.1	66.7	69740
Semidesert	64917.0	11.8	26.9	178890.7	12.1	74.2	241050
Desert	157.1	0.0	22.8	650.0	0.0	94.2	690
Marsh	5144.0	0.9	22.3	15833.8	1.1	68.7	23060
Crops	159282.0	28.9	46.3	306882.9	20.8	89.2	344000
Water	4855.4	0.9	35.7	11065.5	0.7	81.3	13610
Total	550217.5	100.0		1477087.7	100.0		

1541
1542

Table 3.3.B-2. Permissible recreational load for 12-hour weekend recreation over a 6-month period in the total area of accessibility zones around roads and in the 5% of area of these zones, persons

	Total area of accessibility zones				5% of area of accessibility zones			
	500 m zone		2000 m zone		500 m zone		2000 m zone	
	Excursions	Mass daily recreation	Excursions	Mass daily recreation	Excursions	Mass daily recreation	Excursions	Mass daily recreation
Alpine vegetation	19,946	4,986	105,623	26,406	997	249	5,281	1,320
Subalpine meadows	1,681,259	420,315	6,977,748	1,744,437	84,063	21,016	348,887	87,222
Meadow-steppe	1,864,855	466,214	7,004,574	1,751,143	93,243	23,311	350,229	87,557
Steppe	3,613,023	903,256	12,352,798	3,088,199	180,651	45,163	617,640	154,410
Grasslands in forest zone	2,646,912	661,728	6,682,024	1,670,506	132,346	33,086	334,101	83,525
Forest	701,722	175,431	2,676,101	669,025	35,086	8,772	133,805	33,451
Juniper	40,965	9,103	114,137	25,364	2,048	455	5,707	1,268
Broadleaf woodland	207,771	51,943	520,792	130,198	10,389	2,597	26,040	6,510
Semidesert	1,454,141	363,535	4,007,151	1,001,788	72,707	18,177	200,358	50,089
Desert	3,519	880	14,560	3,640	176	44	728	182
Marsh	86,419	21,605	266,007	66,502	4,321	1,080	13,300	3,325
Total	12,320,532	3,078,996	40,721,515	10,177,208	616,027	153,950	2,036,076	508,859

1543
1544
1545
1546
1547
1548
1549
1550

Thus, under uniform distribution of visitors, the total maximum recreational capacity of accessibility zones around roads amounts to many thousands of people, and for grassland ecosystems — to millions of people (Table 3.3.B-3). However, a uniform distribution of recreationists never occurs. As a rule, they concentrate in specific points of interest associated with scenic views, historical sites, or the presence of tourist infrastructure. If we assume that such locations make up, for example, 5% of the total area of each ecosystem type within roadside accessibility zones, then the permissible number of recreationists decreases to tens of thousands in grasslands and hundreds in alpine and juniper ecosystems (Table 3.3.B-3; Figure 3.3.B-5).

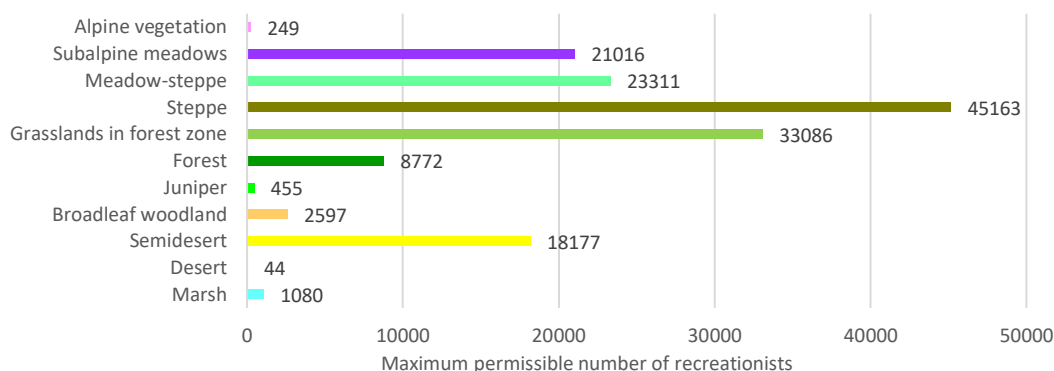

1551
1552
1553

Figure 3.3.B-5. Maximum permissible number of recreationists for 12-hour weekend daily mass recreation over a 6-month period, assuming use is concentrated within 5% of the 0.5 km road-accessible zone in Armenia.

1554 Around 5% of the area of roadside accessibility zones is located within three national parks — Arevik, Arpi Lake, and
 1555 Dilijan (Sevan National Park is not considered in this assessment). In Arevik NP, the road accessibility zones are dominated
 1556 by grasslands in forest zone, with smaller areas of forest, subalpine meadows, and broadleaf woodlands (Fig. 3.3.B-6), in
 1557 Arpi Lake NP, these zones are dominated by meadow-steppe, with smaller areas of subalpine meadows and marshes (Fig.
 1558 3.3.B-7); in Dilijan NP, they are dominated by forests and grasslands in forest zone (Fig. 3.3.B-8; Table 3.3.B-3).
 1559

1560

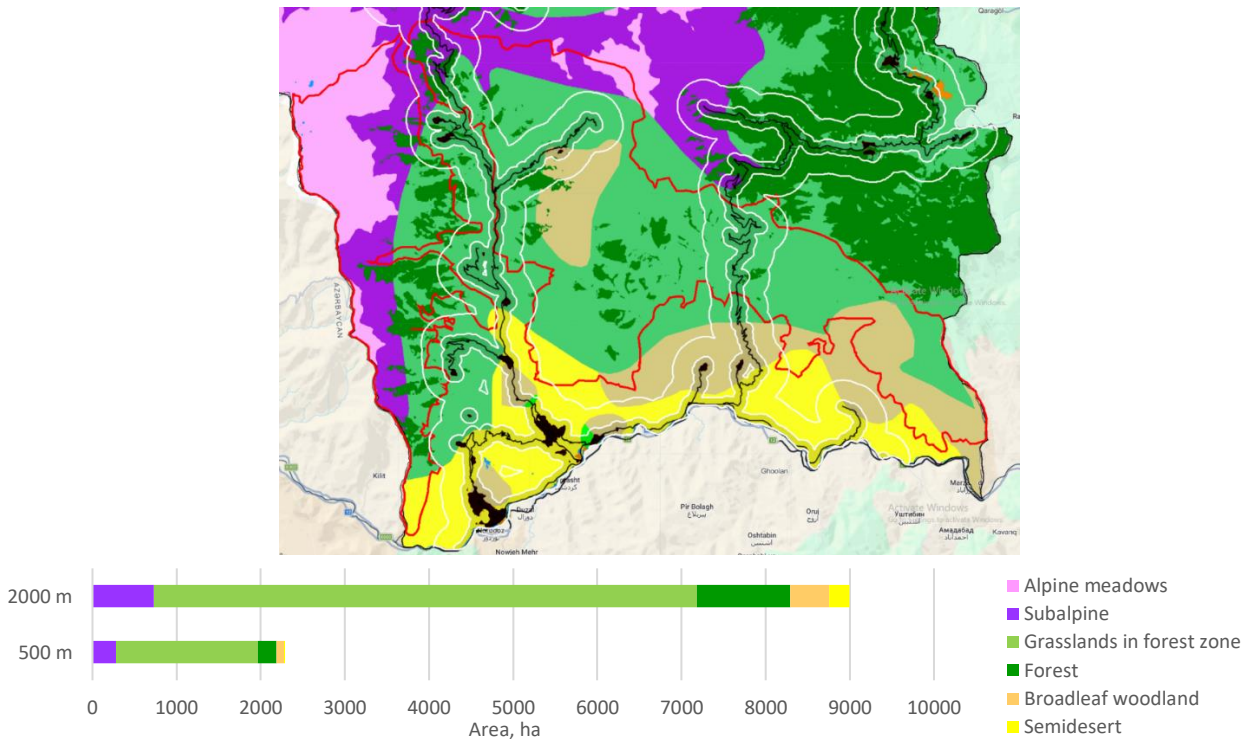

1561

1562 *Figure 3.3.B-6. Accessibility zones of 0.5 km and 2 km around roads in Arevik National Park: a) map showing the NP*
 1563 *boundary in red, settlements and roads in black, and buffer zone boundaries in thin white lines; b) area of different*
 1564 *ecosystem types within the 0.5 km and 2 km accessibility zones. For details see project Web GIS*
 1565 *<https://bccarmenia.nextgis.com/>, section "Ecosystem services. Recreation"*

1566

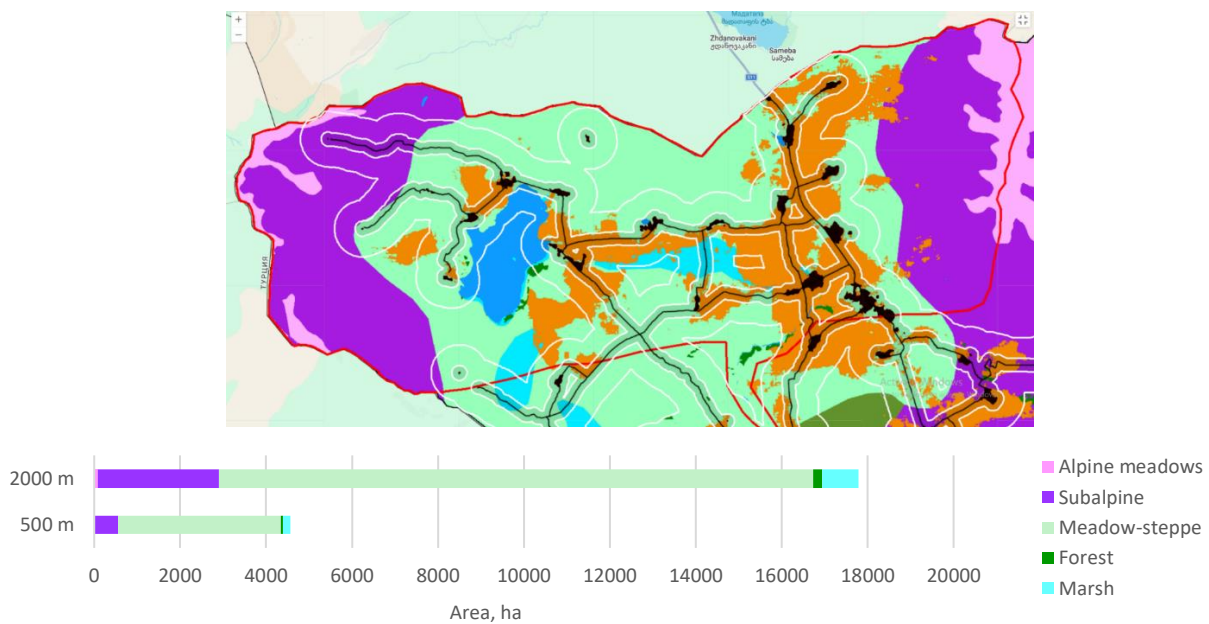

1567

1568 *Figure 3.3.B-7. Accessibility zones of 0.5 km and 2 km around roads in Arpi Lake National Park: a) map showing the NP*
 1569 *boundary in red, settlements and roads in black, and buffer zone boundaries in thin white lines; b) area of different*
 1570 *ecosystem types within the 0.5 km and 2 km accessibility zones. For details see project Web GIS*
 1571 *<https://bccarmenia.nextgis.com/>, section "Ecosystem services. Recreation"*

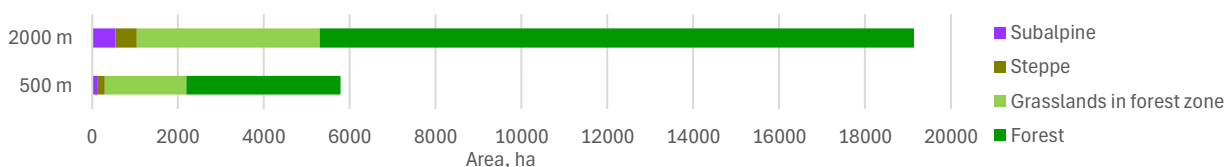
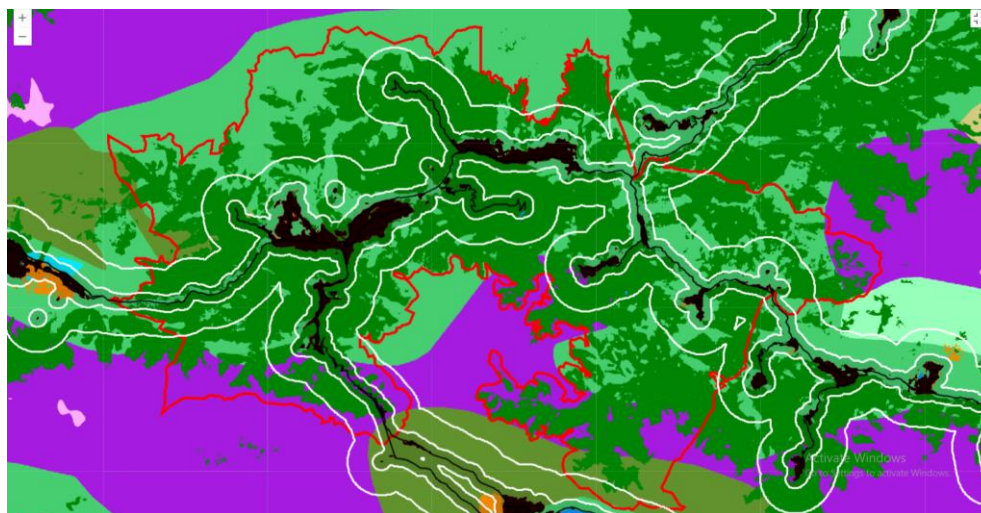

1572

1573

1574 Figure 3.3.B-8. Accessibility zones of 0.5 km and 2 km around roads in Dilijan National Park: a) map showing the NP
 1575 boundary in red, settlements and roads in black, and buffer zone boundaries in thin white lines; b) area of different
 1576 ecosystem types within the 0.5 km and 2 km accessibility zones. For details see project Web GIS
 1577 <https://bccarmenia.nextgis.com/>, section "Ecosystem services. Recreation"

1578

Table 3.3.B-3. Area of different ecosystem types within the 0.5 km and 2 km accessibility zones in three national parks

	Arevik NP		Arpi Lake NP		Dilijan NP	
	500 m	2000 m	500 m	2000 m	500 m	2000 m
Alpine meadows	0	0	0	85.8	0	0
Subalpine	277.6	730.5	558.6	2820.9	130.4	535.8
Meadow-steppe	0	0	3783.8	13828.2	0	0
Steppe	0	0	0	0	156.4	506.3
Grasslands in forest zone	1685.7	6449.0	0	0	1911.1	4254.3
Forest	221.1	1111.2	55.5	208.9	3585.5	13845.2
Broadleaf woodland	90.6	466.1	0	0	0	0
Semidesert	13.4	238.4	0	0	0	0
Marsh	0	0	164.7	844.6	0	0

1579

1580

1581

1582

1583

1584

1585

1586

The maximum permissible average seasonal one-time recreational load R_s for the total roadside 0.5 km accessible zone is determined using the ratio $R_s = 14 R_y$ where R_y is the permissible average annual one-time recreational load indicated in Table 33B-1. Under uniform distribution of visitors, the total maximum recreational capacity of 0.5 km accessibility zone amounts to hundreds and tens of thousands of people (Table 33B-4). However, as in the previous example, a uniform distribution of recreationists across the entire zone appears to be an unrealistic scenario. If we assume, for example, that they concentrate within 20% of this zone, then their maximum permissible number amounts to thousands and tens of thousands (Table 33B-4).

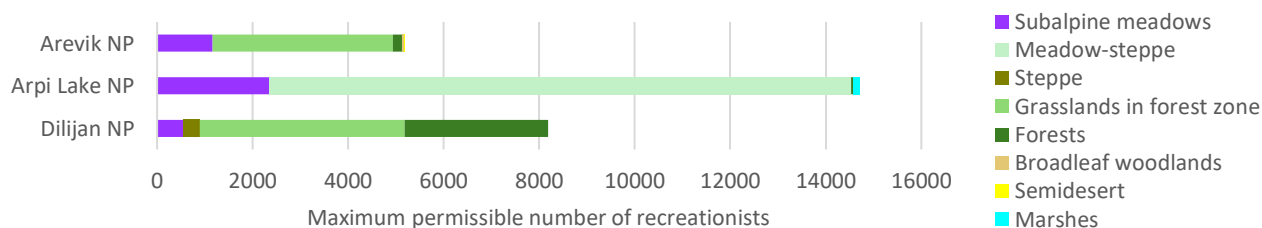

1587

1588

1589

Figure 3.3.B-9. Maximum permissible number of recreationists for 12-hour weekend daily mass recreation over a 6-month period, assuming use is concentrated within 20% of the 0.5 km road-accessible zone in three national parks.

1590
1591

Table 3.3.B-4. Permissible recreational load for 12-hour weekend recreation over a 6-month period in the total area of 0.5 km accessibility zone around roads, in the 20% of this area, persons

	Total area of 500 m accessibility zones						5% of 500 m accessibility zones					
	Arevik NP		Arpi Lake NP		Dilijan NP		Arevik NP		Arpi Lake NP		Dilijan NP	
	Excursions	Mass daily recreation	Excursions	Mass daily recreation	Excursions	Mass daily recreation	Excursions	Mass daily recreation	Excursions	Mass daily recreation	Excursions	Mass daily recreation
Subalpine meadows	23320	5830	46922	11731	10956	2739	4664	1166	9384	2346	2191	548
Meadow-steppe	0	0	243680	60920	0	0	0	0	48736	12184	0	0
Steppe	0	0	0	0	7004	1751	0	0	0	0	1401	350
Grassl. in forest zone	75522	18880	0	0	85617	21404	15104	3776	0	0	17123	4281
Forests	3714	928	933	233	60237	15059	743	186	187	47	12047	3012
Broadleaf woodlands	1015	254	0	0	0	0	203	51	0	0	0	0
Semidesert	301	75	0	0	0	0	60	15	0	0	0	0
Marshes	0	0	2766	692	0	0	0	0	553	138	0	0
Total	103871	25968	294302	73576	163815	40954	20774	5194	58860	14715	32763	8191

1592

3.3.C. Maximum permissible number of hikers in zones accessible from the Transcaucasian Trail

1593
1594
1595
1596

To assess the maximum permissible number of tourists on the Transcaucasian trail (TCT), it was divided into six segments: 1) NP Arpi Lake; 2) segment between NP Arpi Lake and NP Dilijan; 3) NP Dilijan; 4) segment between NP Dilijan and Vayotz Dzor marz boundary; 5) segment between Gegharkunik marz boundary and NP Arevik; 6) NP Arevik (Figure 3.3.C-1).

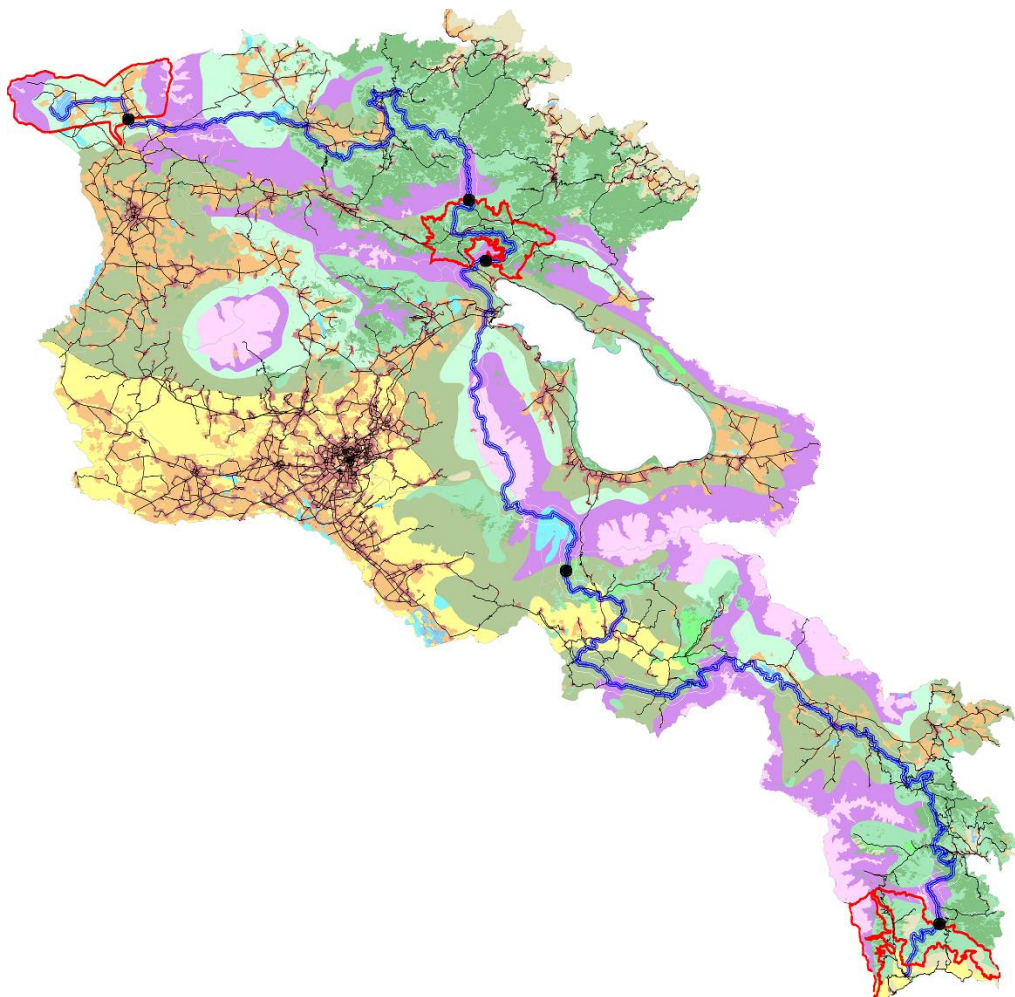

1597
1598
1599
1600

Figure 3.3.C-1. Transcaucasian Trail. The points dividing the TCT into segments are shown in black. The boundaries of the national parks are shown with red lines. The ecosystem map is displayed in a lighter shade for better visibility of the TCT.

1601 Accessibility zones of 50 m and 500 m on both sides of the TCT were delineated. Map fragments showing these
 1602 accessibility zones around the TCT for the three national parks are presented in Fig. 3.3.C-2.
 1603

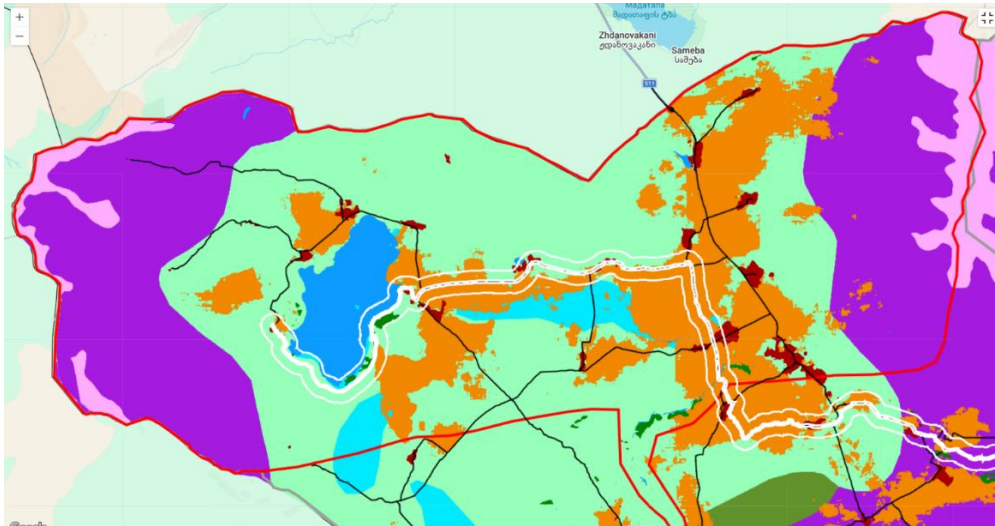

a

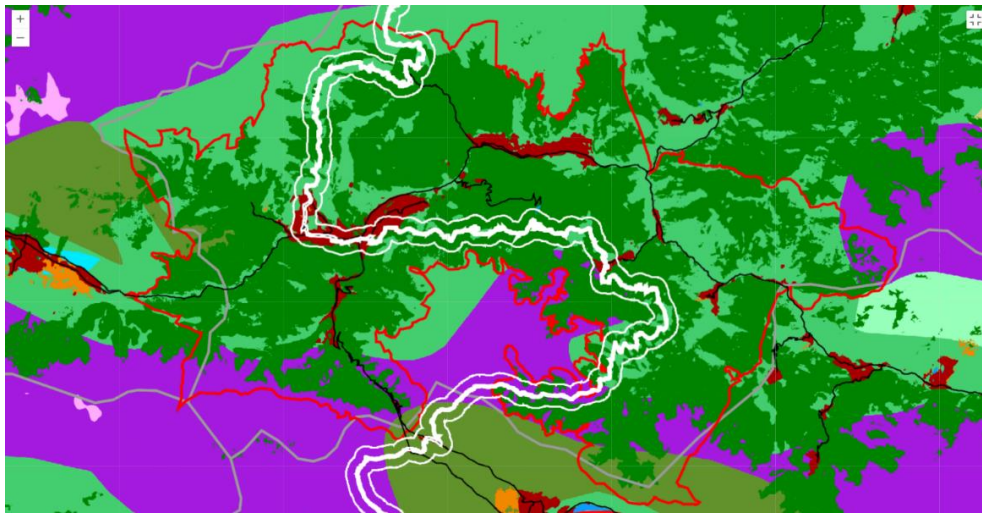

b

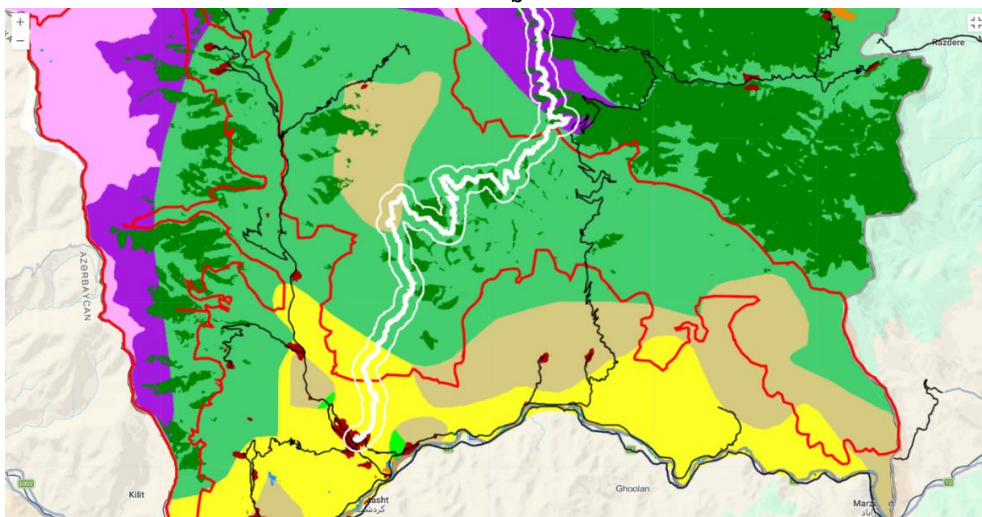

c

1604
1605

1606
1607

1608
1609

1610 *Figure 3.3.C-2. Map fragments showing accessibility zones 500 m and 2000 m around the TCT within three national*
 1611 *parks: a) NP Arpi Lake; b) NP Dilijan; c) NP Arevik. For details see project Web GIS <https://bccarmenia.nextgis.com/>,*
 1612 *section "Ecosystem services. Recreation"*

1613 The TCT segments represent different combinations of ecosystems and anthropogenic areas (Table 3.3.B-5). Within
 1614 the 50 m accessibility zone, they are as follows (Figure 3.3.C-3):

- 1615 - NP Arpi Lake – predominance of croplands and meadow-steppe;
- 1616 - between NP Arpi Lake and NP Dilijan – predominance of grasslands in the forest zone, with significant areas of
 1617 forests, subalpine meadows, and steppe ecosystems; noticeable areas are occupied by croplands and
 1618 settlements;
- 1619 - NP Dilijan – predominance of forests and grasslands in the forest zone;
- 1620 - between NP Dilijan and the Vayots Dzor marz boundary – predominance of alpine and subalpine vegetation and
 1621 steppe ecosystems; there are also substantial areas of marshes;
- 1622 - between the Gegharkunik marz boundary and NP Arevik – predominance of steppe ecosystems with substantial
 1623 areas of grasslands in the forest zone, forests, subalpine and semi-desert ecosystems; this is the only segment of
 1624 the route whose accessibility zone includes juniper open woodlands;
- 1625 - NP Arevik – predominance of grasslands in the forest zone with small patches of forests and semi-desert.

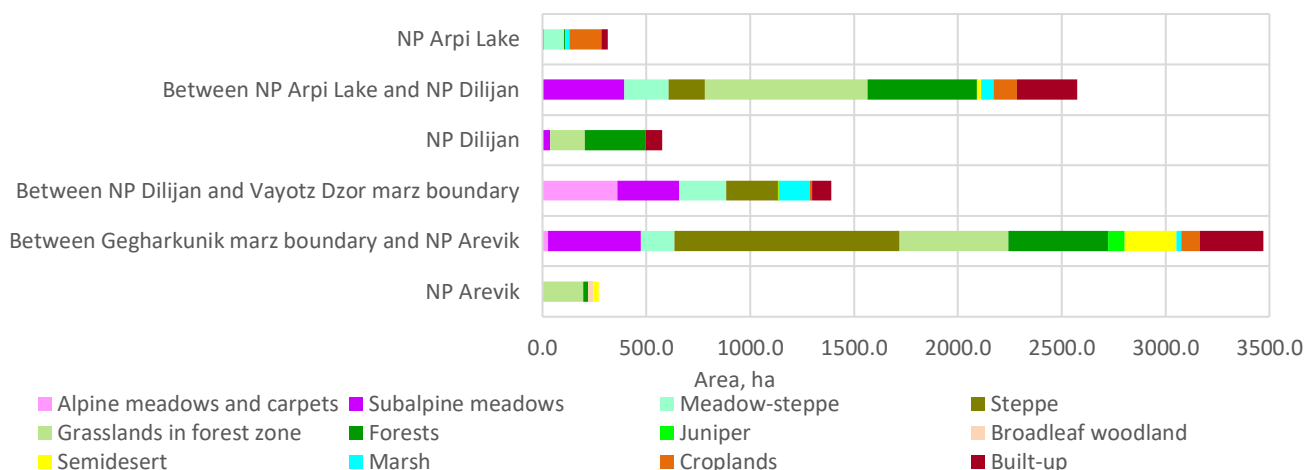

1626
 1627 *Figure 3.3.C-3. Area of different ecosystem types and anthropogenic areas within the 50 m accessibility zone of the TCT*

1628 *Table 3.3.B-5. Area of different ecosystem types and anthropogenic areas within the 50 m and 500 m accessibility zones*
 1629 *of the TCT, ha*

		NP Arpi Lake	Between NP Arpi Lake and NP Dilijan	NP Dilijan	Between NP Dilijan and Vayots Dzor marz boundary	Between Gegharkunik marz boundary and NP Arevik	NP Arevik
Accessibility zone of 50 m	Alpine vegetation	0.0	0.0	0.0	361.1	27.5	0.0
	Subalpine meadows	6.2	393.8	37.6	297.7	446.9	0.0
	Meadow-steppe	96.7	212.7	0.0	227.0	160.5	0.0
	Steppe	0.0	174.8	0.0	247.0	1083.1	0.0
	Grasslands in forest zone	0.0	783.8	167.5	2.3	524.9	197.0
	Forests	5.6	525.7	291.7	1.6	481.6	25.4
	Juniper	0.0	0.6	0.0	0.0	79.7	0.0
	Broadleaf woodland	0.0	0.0	0.0	0.0	0.0	23.9
	Semidesert	0.0	20.5	0.0	2.1	249.3	23.3
	Marsh	20.5	59.3	0.0	149.8	23.0	0.0
	Croplands	154.1	112.8	1.1	10.1	89.2	0.0
	Built-up	30.3	289.9	79.1	92.7	304.8	0.0
Accessibility zone of 500 m	Alpine vegetation	0.0	0.0	0.0	3521.8	207.7	0.0
	Subalpine meadows	34.2	3291.2	243.9	2701.5	4008.4	0.0
	Meadow-steppe	1078.4	1969.7	0.0	2095.7	1465.7	0.0
	Steppe	0.0	1388.1	0.0	2409.9	9501.0	0.0
	Grasslands in forest zone	0.0	5207.5	1237.2	55.8	4356.1	1606.0
	Forests	89.9	2525.9	2855.5	24.3	3900.7	296.8
	Juniper	0.0	4.0	0.0	0.5	606.4	0.0
	Broadleaf woodland	0.0	0.0	0.0	0.0	0.0	191.7
	Semidesert	0.0	192.7	0.0	18.8	2207.7	216.8
	Marsh	100.2	563.4	0.0	1457.0	168.7	0.0
	Croplands	1428.2	1342.3	0.0	235.5	873.1	0.0
	Built-up	135.7	1364.9	497.6	614.1	1821.6	0.0

1630 The permissible seasonal number of tourists R_s was calculated assuming their 24-hour presence throughout all days
 1631 of the six-month period, i.e., half of the year. Thus, in accordance with the equation 3.3.B-1, $R_s = 2 R_y$ where R_y is the
 1632 permissible average annual one-time recreational load indicated in Table 3.3.A-1.

1633 *Table 3.3.B-6. The maximum allowable simultaneous number of hikers in 50 m and 500 m accessibility zones around TCT*
 1634 *for 6-month period*

		NP Arpi Lake	Between NP Arpi Lake and NP Dilijan	NP Dilijan	Between NP Dilijan and Vayots Dzor marz boundary	Between Gegharkunik marz boundary and NP Arevik	NP Arevik	Total
Managed tourism in 50 m accessibility zone	Alpine vegetation	0	0	0	325	25	0	350
	Subalpine meadows	25	1,575	151	1,191	1,787	0	4,729
	Meadow-steppe	290	638	0	681	482	0	2,091
	Steppe	0	385	0	543	2,383	0	3,311
	Grasslands in forest zone	0	627	134	2	420	158	1,340
	Forests	12	1,156	642	3	1,060	56	2,929
	Juniper	0	0	0	0	48	0	48
	Broadleaf woodland	0	0	0	0	0	14	14
	Semidesert	0	20	0	2	249	23	295
	Marsh	18	53	0	135	21	0	227
	Total	346	4,456	926	2,883	6,474	251	15,335
Managed tourism in 500 m accessibility zone	Alpine vegetation	0	0	0	3,170	187	0	3,357
	Subalpine meadows	137	13,165	976	10,806	16,034	0	41,118
	Meadow-steppe	3,235	5,909	0	6,287	4,397	0	19,828
	Steppe	0	3,054	0	5,302	20,902	0	29,258
	Grasslands in forest zone	0	4,166	990	45	3,485	1,285	9,971
	Forests	198	5,557	6,282	53	8,582	653	21,325
	Juniper	0	2	0	0	364	0	366
	Broadleaf woodland	0	0	0	0	0	115	115
	Semidesert	0	193	0	19	2,208	217	2,637
	Marsh	90	507	0	1,311	152	0	2,060
	Total	3,660	32,553	8,247	26,993	56,310	2,270	130,033
Self-organized tourism in 50 m accessibility zone	Alpine vegetation	0	0	0	144	11	0	155
	Subalpine meadows	11	709	68	536	804	0	2,128
	Meadow-steppe	135	298	0	318	225	0	976
	Steppe	0	175	0	247	1,083	0	1,505
	Grasslands in forest zone	0	314	67	1	210	79	670
	Forests	6	526	292	2	482	25	1,332
	Juniper	0	0	0	0	16	0	16
	Broadleaf woodland	0	0	0	0	0	5	5
	Semidesert	0	8	0	1	100	9	118
	Marsh	8	24	0	60	9	0	101
	Total	160	2,053	426	1,308	2,940	118	7,006
Self-organized tourism in 500 m accessibility zone	Alpine vegetation	0	0	0	1,409	83	0	1,492
	Subalpine meadows	62	5,924	439	4,863	7,215	0	18,503
	Meadow-steppe	1,510	2,758	0	2,934	2,052	0	9,254
	Steppe	0	1,388	0	2,410	9,501	0	13,299
	Grasslands in forest zone	0	2,083	495	22	1,742	642	4,984
	Forests	90	2,526	2,856	24	3,901	297	9,694
	Juniper	0	1	0	0	121	0	122
	Broadleaf woodland	0	0	0	0	0	38	38
	Semidesert	0	77	0	8	883	87	1,055
	Marsh	40	225	0	583	67	0	915
	Total	1,701	14,982	3,789	12,252	25,566	1,064	59,354

1635 Under a uniform distribution of self-organized hikers i within a 50-m zone around the TCT, their maximum permissible
 1636 number for a TCT segment in Arpi Lake National Park at any given time is 160 people, in Dilijan National Park – 426 people,
 1637 and in Arevik National Park – 118 people, with a total of 7,006 people along the route. If hikers are concentrated in
 1638 specific scenic and convenient locations, for example within 20% of this zone, their permissible numbers should be
 1639 reduced accordingly to 32, 85, and 24 people, respectively, with an overall allowable total of 1400 people along the entire
 1640 TCT (Figure 3.3.C-4). Subalpine meadows, steppes, meadow-steppes, and forests have the highest total recreational
 1641

1642 capacity along the entire TCT. Within the Arpi Lake NP segment, this capacity is highest in meadow-steppes; in Dilijan NP
 1643 – in forests; and in Arevik NP – in grasslands within the forest zone (Figure 3.3.C-4).

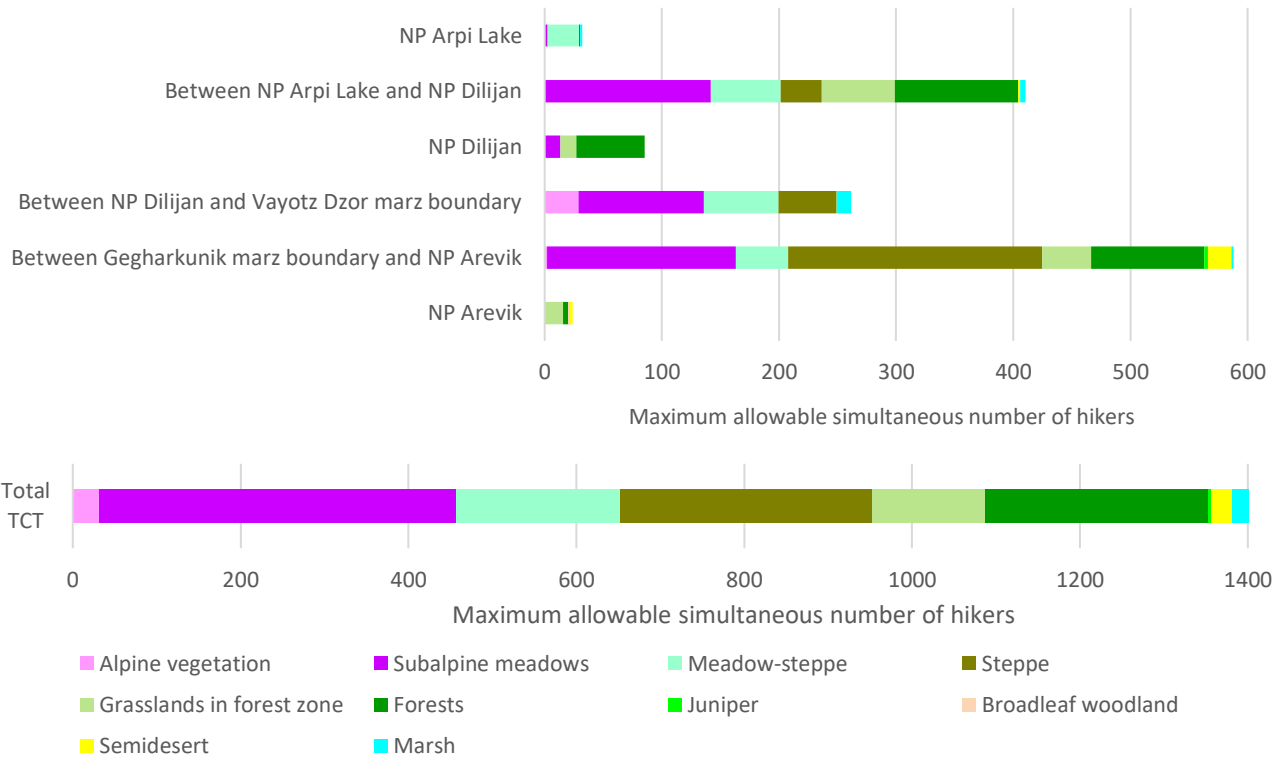

1644

1645

1646

1647

Figure 3.3.C-4. The maximum allowable simultaneous number of self-organized hikers under their uniform distribution within 20% of the 50-m accessible zone around the TCT during a six-month period

3.4. Non-material ES: biodiversity in Armenian culture

Photographs by Armine Arshakyan and Elena Bukvareva are used as illustrations unless another source is indicated

Armenia's rich biodiversity has left an indelible mark on the culture, beliefs, and traditions of its people for centuries. The diverse ecosystems of the Armenian Highlands—from forests to alpine meadows and mountain rivers—not only provided livelihoods but also shaped national identity.

Armenian folklore is rich in myths and tales about nature. In the epic of David of Sassoun and other legends, animals and plants often appear as symbols or helpers. The bear, the eagle, and other native animals have become symbols of bravery, wisdom, and strength.

In Armenian art and architecture, natural motifs hold a prominent place. In the patterns of khachkars (cross-stones), manuscript miniatures, and temple ornaments, depictions of local flora and fauna are often found. Motifs of pomegranate, grapevine, and wheat—plants that grow abundantly on Armenian soil—have become symbols of fertility and abundance.

The traditional way of life of Armenian rural communities has always been closely connected to nature. Since ancient times, Armenians have developed agricultural practices adapted to local natural conditions. This traditional knowledge has been passed down from generation to generation, helping to maintain a sustainable relationship between humans and nature.

In the Armenian calendar of holidays, many celebrations and rituals are dedicated to nature and its cycles. Vardavar, Ascension, and other festivals symbolize the rebirth of nature, fertility, and the connection between humans and the environment.

In modern Armenia, there is increasing emphasis on the need for nature conservation and sustainable development. The preservation of Lake Sevan, the forests of Dilijan, and other biodiversity hotspots has become not only an environmental issue but also a cultural one, aimed at safeguarding national heritage.

3.4.A. Ancient times: the sacred power and beauty of Nature

In ancient Armenia, nature held a sacred meaning. Trees, stones, and water sources often became objects of worship. In ancient Armenian beliefs, animals frequently acted as embodiments of natural forces, both good and evil. Dangerous or mythical creatures were associated with chaos, destructive forces, or the struggle between good and evil.

In the beliefs of the pagan period, many deities and spirits were associated with various natural phenomena and animals. For example, the figure of Vahagn, the god of thunder and lightning, was closely linked to the natural elements. Vahagn was known for his struggle against evil, often embodied in giant snakes or dragons (Fig. 3.4.A-1).

Powerful animals symbolize strength, protection, and divine order (Fig. 3.4.A-2).



Figure 3.4.A-1. Vahagn the Dragonslayer engraving by Austrian artist J. Rotter (https://commons.wikimedia.org/wiki/File%3AVahaqn_the_Dragonslayer.jpg?utm_source=)



1683



1684

1685

1686

Figure 3.4.A-2. Wall painting from the Temple of the god Haldi, 8th–7th century BC, Erebuni; bull head, 7-8 century BC, Echmiadzin; lion, 7th century BC, Karmir Blur; bear-shaped rhyton, 1 century, History Museum of Armenia

1687

1688

1689

1690

1691

However, since ancient times, art has reflected not only power but also the beauty of nature. The elegance of animals depicted in ancient treasures found in the territory of Armenia is truly striking. At the famous Bronze Age archaeological site of Lchashen on the shores of Lake Sevan, figurines of deer, goats, and birds were found as part of the ritual burial assemblage. They may have symbolized the soul or served as intermediaries between the earthly and spiritual worlds. Extremely refined depictions of animals were also found in other places (Fig. 3.4.A-3).



1692

1693

1694

1695

Figure 3.4.A-3. Birds, 15th–14th centuries BC, found in Lchashen (a); deer, 12-11 century BC, Tolors (b); ibex, 13 century BC, Artik (c), History Museum of Armenia

1696

3.4.B. Middle ages

1697

Christianity: nature as a manifestation of God's creation - the fusion of ancient and new meanings

1698

1699

1700

1701

After the adoption of Christianity, although overt forms of nature worship disappeared, respect for nature and its symbolic significance was preserved. Many monasteries and churches were built in picturesque natural settings, emphasizing the harmony between spirituality and nature. In miniature images, on khachkars, and in other works of art, plant and animal motifs are often found, carrying both decorative and symbolic significance (for example, the tree of life).

1702 In the doctrine of the Armenian Apostolic Church, nature is regarded as part of God's creation, imbued with harmony
 1703 and beauty. Many spiritual figures and theologians have reflected on nature in their works, emphasizing human
 1704 responsibility toward it and the importance of its preservation. In prayers and hymns, references to nature are frequently
 1705 found, praising the greatness and wisdom of God as manifested in the natural world.
 1706



1707



1708



1711



1713



1714

1715 *Figure 3.4.A-4. Fragment of Canon Table Page from the Zeytun Gospels, Toros Roslin, 1256³⁴ ; vegetal motif on a temple*
 1716 *portal at Geghard, 13th century; ram-shaped tombstone, 1579, History Museum of Armenia; the upper frieze of the*
 1717 *Cathedral of the Holy Cross in Aghtamar Island (Lake Van, Turkey) 10 century³⁵; animals on the same Cathedral³⁶; ibex*
 1718 *on the Holy_Mother_of_God_Church,_Yeghvard³⁷; fragment of ornament with plants and animals, wooden door from*
 1719 *the monastery in Mush, 1134, History Museum of Armenia.*

³⁴ Wikimedia Commons: https://commons.wikimedia.org/wiki/Special:FilePath/T%27oros_Roslin_%28Armenian%2C_active_1256_-_1268%29_-_Canon_Table_Page_-_Google_Art_Project_%283789685%29.jpg

³⁵ Photograph by Verity Cridland, Flickr, licensed under CC BY 2.0 <https://www.flickr.com/photos/58789412@N00/1532507101/in/photostream/>

³⁶ Photograph by Verity Cridland, Flickr, licensed under CC BY 2.0. <https://www.flickr.com/photos/58789412@N00/1533391042/>

³⁷ Photograph by Dav Sargsyan / Wikimedia Commons. Licensed under CC BY-SA 4.0. https://en.wikipedia.org/wiki/Holy_Mother_of_God_Church,_Yeghvard

1720
1721
1722
1723
1724
1725
1726

Nature symbols in culture

Ancient symbols of the strength of nature were organically integrated into Christian symbolism. Each of them carries a profound, multilayered meaning, combining the most ancient and later symbolic traditions.

The eagle, the lion, and the bull. These ancient symbols of strength, fertility, and authority were adopted by the Christian tradition, where they acquired different meanings depending on the context, while simultaneously preserving their ancient significance and referring to the Evangelists and other Christian symbols (Figures 3.4.A-5, 3.4.A-6)



1727
1728
1729

Figure 3.4.A-5. Eagle on the capital of early-Christian temple, Zvartnots, 7th century; bull and lion on the Holy Mother of God Church, Yeghvard³⁸



1730
1731

Figure 3.4.A-6. Lions, bulls, and eagles as symbols of the Evangelists in the Amida Gospels, Armenia, early 17th century³⁹

1732
1733
1734
1735
1736
1737
1738

A lion-like hero. In Armenian cultural tradition, the lion embodies extraordinary strength, bravery, protection, and royal authority. In the national epic *David of Sassoun*, which took shape in the Middle Ages, the figure of Great Mher (Mets Mher) is closely associated with the symbol of the lion. Mher proves his heroic nature by defeating a giant lion that had blocked the people’s access to bread. By tearing the beast in two, he restores the flow of life and sustenance to the community. For this feat, he was given the name Lion-Mher, a mighty defender of his people. Confirmation of the medieval association of a fearless and strong man with a lion is the tombstone of Elikum III Orbelian in Noravank (Figure 3.4.A-7).

³⁸ Photograph by Steven C. Price / Wikimedia Commons. Licensed under CC BY-SA 4.0, https://en.wikipedia.org/wiki/Holy_Mother_of_God_Church,_Yeghvard

³⁹ Walters Art Museum, MS W.541, fol. 5r. <https://www.thedigitalwalters.org/Data/WaltersManuscripts/html/W541/>



1739
1740
1741

Figure 3.4.A-7. Illustration by Mihran Sosoyan for the 1966 edition of the epic *David of Sassoun*; tombstone of Elikum III Orbelian, 1300, Noravank.

1742
1743
1744
1745
1746
1747
1748
1749

The struggle between the lion and the bull. One of the most ancient symbols of opposing natural forces, order and chaos, light and darkness, and even astronomical and seasonal cycles — came to signify the triumph of the Christian faith over pagan or chaotic forces. The wild bull was pacified and became a helper of humankind and one of the symbols of Christianity. This scene may also be associated with the power of princely or royal authority. At Geghard, on the famous relief with lions in the rock-cut church, the head of a horned animal (bull, ram, or ibex) is depicted above them. This may symbolize the interconnection and balance of these ancient symbols, or it could relate to Proshyan dynastic or regional iconography. (Figure 3.4.A-8).

1750
1751
1752



Figure 3.4.A-8. The struggle between a lion and a bull above the portal of the temple at Geghard and lions in rock temple in Geghard, 13th century.

1753
1754
1755
1756

The eagle with its prey. In Christian tradition, this motif came, on the one hand, to signify the salvation of the soul through the association of the eagle with lofty faith and spirit and the lamb with sacrificial purity; on the other hand, it conveyed the idea of the protection of the Church and the people by royal authority, long symbolically linked with the eagle (Figure 3.4.A-9).



1757

1758 *Figure 3.4.A-9. Eagles with prey: an eagle depicted above the portal of the church at Noravank Monastery, 13 century⁴⁰;*
 1759 *an eagle from Kecharis monastery, 11 century, History Museum of Armenia.*

1760

1761 **The dove.** In the Christian context, the dove symbolized the Holy Spirit and is depicted on many churches, both on
 1762 the exterior and in the interior (Figure 3.4.A-10).

1763 **The peacock.** In Armenian Christian art, the peacock symbolizes immortality and eternal life and is often depicted in
 1764 manuscripts beside paradise trees, evoking the imagery of the heavenly garden and resurrection. (Figure 3.4.A-11).
 1765



1766



1767

1768 *Figure 3.4.A-10. Doves on the temple portal in Geghard, 13th century; dove inside the temple in Noravank, 13th–14th*
 1769 *century; wooden capital, Sevanavank, 847, History Museum of Armenia*

⁴⁰ Photograph by Soghomon Matevosyan / Wikimedia Commons. Licensed under CC BY-SA 4.0,
https://commons.wikimedia.org/wiki/Category%3ANoravank_%28sculpture%29?utm_source



1770

1771 *Figure 3.4.A-11. Peacock and other birds on paradise trees in Canon Tables: the Gladzor Gospels, early XIV century⁴¹; the*
 1772 *Zeyton Gospels, Toros Roslin, 1256⁴²*

1773 **The pomegranate.** This tree has been considered an important part of Armenian culture since pagan times and carries
 1774 several significant symbolic meanings:

- 1775 - Fertility and motherhood. The numerous seeds of the pomegranate symbolize many children and the continuation
 1776 of life.
- 1777 - Unity. The many seeds contained within a single fruit have become a symbol of solidarity and national unity.
- 1778 - Wedding symbol. In ancient times, pomegranate seeds were scattered in front of the bride during a wedding
 1779 ceremony as a wish for fertility.

1780 After the adoption of Christianity, the pomegranate remained a symbol of holiness and eternal life. Images of
 1781 pomegranates can be found in the sculpture and manuscript illumination of Armenian church art (Figure 3.4.A-12).
 1782



1783

1784 *Figure 3.4.A-12. Pomegranate and grape on the temple portal in Geghard, 13 century; fragment of the upper frieze of*
 1785 *the Cathedral of the Holy Cross in Aghtamar Island (Lake Van, Turkey) 10 century⁴³*

⁴¹ <https://www.getty.edu/art/collection/object/107SQF>

⁴² [https://commons.wikimedia.org/wiki/File:T%27oros_Roslin_\(Armenian,_active_1256_-_1268\)_-Canon_Table_Page_-_Google_Art_Project_\(6908051\).jpg](https://commons.wikimedia.org/wiki/File:T%27oros_Roslin_(Armenian,_active_1256_-_1268)_-Canon_Table_Page_-_Google_Art_Project_(6908051).jpg)

⁴³ Photograph by Verity Cridland, Flickr, licensed under CC BY 2.0. <https://www.flickr.com/photos/58789412@N00/1532519029/in/photostream/>

1786 **The plane tree.** *Platanus orientalis*, with its majestic appearance, longevity, and strength, has deep roots in the
 1787 culture, history, and beliefs of the Armenian people, becoming the bearer of numerous symbolic meanings. The plane
 1788 tree has at times been regarded as sacred, with various rituals and customs associated with it. In some regions, people
 1789 believed that the tree could help fulfill wishes, and for this reason pieces of cloth were tied to its branches. It was also
 1790 sometimes considered the dwelling place of nature spirits or the spirits of ancestors. The attitude toward the plane tree
 1791 was one of care and reverence, and damaging it was regarded as a sin or an act that could bring misfortune.

1792 **Tree of Life.** In Armenian Christian tradition, the cross is usually surrounded by vegetal ornamentation and depicted
 1793 as a growing or blossoming tree. The Armenian cross symbolizes the triumph of life over death, resurrection, and eternal
 1794 life (Figure 3.4.A-13).
 1795



Figure 3.4.A-13. Crosses in Tatev monastery

1796
 1797
 1798 Ancient symbols are still preserved in Armenian culture today (Figure 3.4.A-14).
 1799



Figure 3.4.A-14. Fragments of khachkars in Tsaghkevank

1800
 1801
 1802

1803
1804
1805
1806
1807
1808
1809
1810
1811
1812
1813
1814
1815

Bird letters

The method of drawing letters in which birds or other animals are not interwoven into the letter as a part of it, but themselves form entire letters, which are not only used as initials but can also compose whole words, is to a large extent a unique achievement of Armenian medieval calligraphy. In Armenian manuscripts there are letters in the form of people, animals, fish, and dragons. However, bird letters became the most enduring form. Birds are plastic in form and are the easiest to transform into letters, as they have elements that easily correspond to the strokes of a letter: the curves of the neck, and strokes resembling a beak, a tail, or a wing. But most importantly, they carry a special positive and elevated meaning in Christian symbolism, representing heaven, the soul, ascension, and the message of God. Therefore, bird letters, beyond their beauty, conveyed the idea of the connection between earth and heaven and of spiritual ascent through the reading of the sacred text. In the Middle Ages, the sacred book was perceived as a small model of the world, adorned with images of human life and nature. With bird letters, it seems that writing itself becomes a part of living nature.

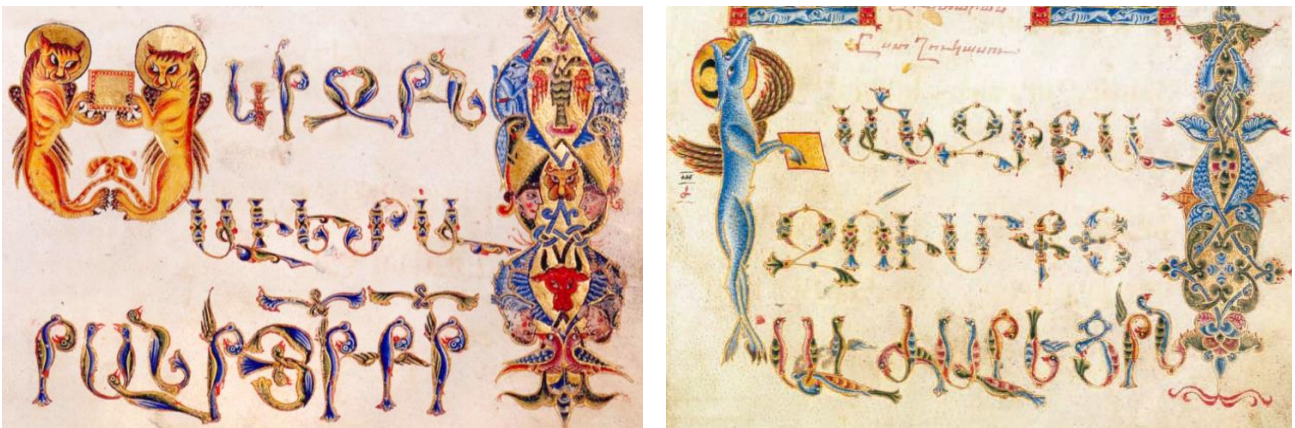

1816
1817

Figure 3.4.A-15. Fragments of the Gladzor Gospels, early XIV century⁴⁴



1818
1819

Figure 3.4.A-16. Fragments of the Bible, 1637–1638⁴⁵

⁴⁴ Mathews, Thomas F., and Alice Taylor. The Armenian Gospels of Gladzor: The Life of Christ Illuminated. Los Angeles: J. Paul Getty Museum, 2001. Available at: The Getty Virtual Library, <https://www.getty.edu/publications/resources/virtuallibrary/0892366273.pdf>

⁴⁵ The J. Paul Getty Museum, Los Angeles, Ms. Ludwig I 14, fol. 321, 83.MA.63.321, <https://www.getty.edu/art/collection/object/103RTM>

1820
1821
1822
1823
1824
1825
1826
1827
1828
1829
1830
1831
1832
1833
1834
1835
1836
1837

3.4.C. Animals and plants in Armenian folk culture

Folklore

Animals and plants play an important role in Armenian folklore. In proverbs, fairy tales, songs, and sayings, animals and plants frequently appear as symbols that embody human qualities or convey moral lessons. For example, the fox often symbolizes cunning, the bear strength, and the swallow the arrival of spring and hope.

In Armenian folk tales, animals and plants represent different character traits, natural forces, and human values. Foxes, wolves, bears, birds, and domestic animals appear as clever, brave, or wise characters, teaching lessons about survival, cooperation, and respect for nature. These stories reflect careful observation of the surrounding environment and demonstrate how communities understood and valued the diversity of local species.

For instance, the clever fox often outsmarts stronger animals, symbolizing intelligence and adaptability. Birds may carry messages or guide heroes, while domestic animals such as sheep or horses emphasize the close relationship between people and the land.

Through such narratives, Armenian communities preserved knowledge about species, their behavior, and their roles in nature, embedding ecological wisdom in cultural memory. Folk tales thus serve as a bridge between tradition and the natural world, encouraging respect for biodiversity and awareness of ecological balance.

Many fables and parables were written by the Armenian fabulist and preacher Vardan Aygektsi as early as the 13th century (Figure 3.4.C-1)



1838
1839
1840
1841
1842
1843
1844
1845
1846
1847
1848
1849
1850
1851
1852

Figure 3.4.C-1. The Fables of Vardan Aygektsi.

Folk crafts and artisanry

Armenia’s folk crafts and traditional artisanry reflect the country’s rich natural heritage. Artisans have long depicted plants, animals, and other natural motifs in their works, celebrating the surrounding environment. Carpets (Fig. 3.4.C-2), woodcarving (Fig. 3.4.C-3), embroidery, pottery, and metalwork often feature flowers, trees, birds, and animals, illustrating the close relationship between cultural expression and nature. These representations preserve elements of Armenian artistic heritage and reflect a traditional awareness of the natural world. By incorporating images of local species into decorative designs, artisans express a deep connection with the landscape and its living forms. Folk crafts thus serve as a bridge between culture and nature, demonstrating how artistic traditions can reflect and celebrate the richness of the natural environment.

Armenian pottery and ceramics have a history that spans thousands of years, reflecting close relationship with nature. Traditional pottery uses locally sourced clay, often shaped by hand or on a potter’s wheel, and is decorated with geometric patterns, floral designs, or animal motifs. These decorations are not merely ornamental—they often symbolize cultural beliefs, local legends, or the natural world (Fig. 3.4.C-4).



1853

1854

1855

Figure 3.4.C-2. Artsakh carpet, 1896⁴⁶; odzagorg – armenian “snake-carpet, 1860, Chondzoresk, Karabakh, 1860⁴⁷; carpet with the pair of peacocks⁴⁸



1856

1857

1858

1859

Figure 3.4.C-3. Daghdghan is a traditional amulet and protective charm. Daghdghans were made from trees that were considered sacred. In its simplest form, such an amulet could take the shape of a simple bead, because the wood of a sacred tree was believed to provide protection on its own.

⁴⁶ https://ru.wikipedia.org/wiki/%D0%A4%D0%B0%D0%B9%D0%BB:Karabagh_Carpet_1896_Will.jpg

⁴⁷ https://ru.wikipedia.org/wiki/%D0%A4%D0%B0%D0%B9%D0%BB:Chondzoresk_Karabakh_1860_AlbertoLeviGallery.jpg

⁴⁸ https://commons.wikimedia.org/wiki/File:Armenian_rug_,_No._0588626.jpg



Figure 3.4.C-4. Modern Armenian ceramics from Jerusalem⁴⁹.

1860

1861

1862

3.4.D. Contemporary art

1863

1864

1865

1866

1867

1868

In Armenian literature, from ancient times to the modern period, nature has always been an important theme and source of inspiration. Poets, prose writers, and painters have often depicted the beauty of Armenia's natural world: mountains, fields, rivers, trees, and flowers. Scenes of nature not only create a backdrop for action, but also express the feelings and thoughts of the characters or symbolize universal ideas. Prominent writers and artists (for example, Hovhannes Tumanyan, Derenik Demirchyan, Martiros Saryan) devoted much attention to Armenian nature in their works.

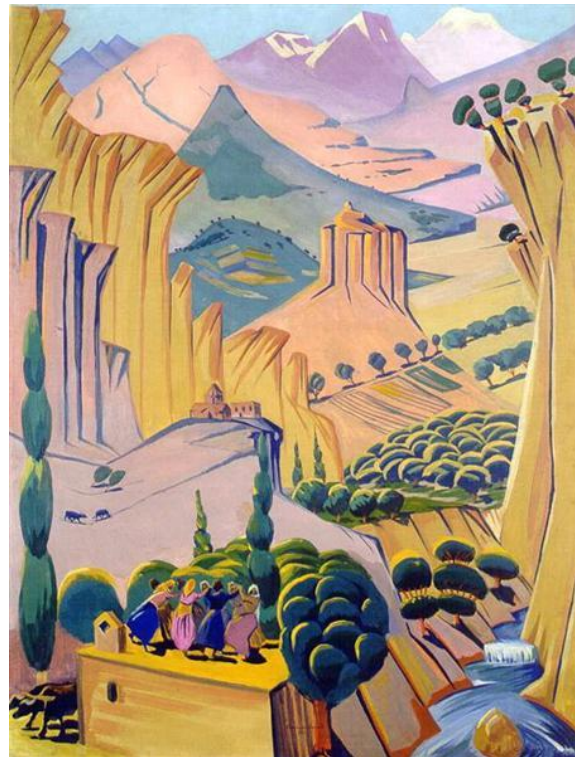

Figure 3.4.D-1. Martiros Sarian: Mountains, 1923; Armenia, 1923⁵⁰

1869

1870

1871

⁴⁹ Armenian ceramics, Armenian Quarter, Jerusalem. Photo: Deror avi, Wikimedia Commons, CC BY-SA 3.0.

https://commons.wikimedia.org/wiki/File%3AArmenian_Ceramics_IMG_5016.JPG?utm_source;

https://commons.wikimedia.org/wiki/File:Armenian_Ceramics_P1130729.JPG

⁵⁰ <https://www.wikiart.org/en/martiros-sarian/>. Public Domain.

1872

1873

3.5. ES accounting: summary and discussion

1874

The aggregate values of ES potential demonstrate their key importance for the economy and population of Armenia, as well as for assessing the country’s contribution to mitigating global and regional environmental problems, including climate change and water crisis.

1875

1876

1877

Table 3.5-1. Total potential/capacity of quantitatively estimated ES

ES	Indicators of ES potential/capacity	Indicator values
Production of forage and fodder by natural grasslands	Maximum allowable stocking rate (all grasslands)	0.54 LU/ha* 1,111,000 LU
	Maximum allowable stocking rate (non-degraded grasslands)	0.44 LU/ha 913,000 LU
Storage of carbon in ecosystems in soil and tree biomass	Carbon content	53 tC/ha
	Carbon stock	151 Mtc
Ecosystem effect on surface temperature	Ecosystem effect on cooling capacity	0.04
Prevention of soil water erosion	Avoided erosion	46.4 t/ha/year 140.4 Mt/year
Prevention of ediment export to streams	Avoided sediment export	4.3 t/ha/year 13.0 Mt/year
Baseflow maintenance	Baseflow provided by ecosystems	47.8 mm/year 2212 million m ³ /year
Flood risk mitigation	Ecosystem effect on quick runoff	- 4.1 mm/year
	Runoff retention provided by ecosystems	0.4 mm/year 119 million m ³ /year

1878

*LU – livestock unit

1879

Terrestrial ecosystems perform between 11% and 96% of the modeled water-related regulating ES (Table 3.5-2). Ecosystems have the strongest impact on baseflow supply and erosion prevention, performing these functions almost entirely (93–96%). ES maps show that under the bare ground scenario, baseflow is almost absent (Section 3.1.A2), meaning that the existing baseflow is almost entirely provided by terrestrial ecosystems. At the same time, under the current land cover, erosion is virtually absent (Section 3.1.A3), indicating that ecosystems almost completely prevent it. Only in the case of ES for flood mitigation under the average spring rainfall scenario (12 mm) was the effect of ecosystems negligible. Runoff retention and quick runoff values change only slightly in absolute terms between the current land cover and the bare ground scenario. However, even in this case, ecosystems reduce quick runoff by 14%.

1880

1881

1882

1883

1884

1885

1886

1887

Table 3.5-2. Results of ES modeling for the territory of Armenia.

ES and InVEST model	Indicator	Land cover 2023	Bare ground scenario	ES Provided by natural ecosystems	The share of ES provided by ecosystems %
Seasonal water flow regulation and baseflow provision SWY	Baseflow	51.3 mm (BFI * = 34%)	3.4 mm (BFI = 3%)	47.8 mm	+93%
	Quick flow	98.0 mm	120.2 mm	-22.2 mm	-18%
Prevention of soil water erosion and sediment transport to waterbodies SDR	Erosion	2.3 t/ha/year 6.8 Mt/year	48.6 t/ha/year 147.2 Mt/year	Avoided erosion -46.4 t/ha/year -140.4 Mt/year	-95%
	Sediment export	0.15 t/ha/year 0.47 Mt/year	4.5 t/ha/year 13.5 Mt/year	Avoided sediment export -4.3 t/ha/year -13.0 Mt/year	-96%
Flood risk mitigation, 50 mm rainfall scenario UFRM	Quick runoff, mm	13.3	17.4	-4.1	-24%
	Runoff retention, m ³	3.7	3.3	0.4	+11%
12 mm rainfall scenario UFRM	Quick runoff, mm	0.19	0.22	-0.03	-14%
	Runoff retention, m ³	1.18	1.18	0	0
Cooling effect UC	Cooling capacity	0.19	0.15	0.04	+21%

1888

* BFI—baseflow index, BFI = B/(B + QF).

1889 Our average estimate of the erosion rate for Armenia, 2.3 t/ha/year, is very close to the values for Armenia (2.44–
 1890 2.47) in the global database of modeled erosion values⁵¹ (Borrelli et al., 2017). Neighboring countries (Georgia,
 1891 Azerbaijan, Iran, Turkey) have similar estimates in this database—around 2–3 t/ha/year. According to Eurostat, erosion
 1892 in most Mediterranean countries has a similar intensity, ranging from 2 to 5 t/ha/year⁵².

1893 The average share of baseflow in total flow, calculated based on SWY modeling results, is 34%, which corresponds to
 1894 the baseflow index estimate for Armenia according to the AQUASTAT data⁵³ and methodology of 35.5% (the overlap
 1895 share of the internal renewable surface water resources) (Vallée and Margat, 2003).

1896 Modeling results for the prevention of erosion and sediment transport (SDR model) align most closely with the
 1897 commonly accepted understanding of this ES. The SDR model identified forests as the most effective land cover class for
 1898 preventing erosion, with rangelands and croplands performing worse. Among natural vegetation types, forests and
 1899 woodlands provide this ES most effectively, followed by mountain meadows and then by steppes (Section 3.1.C1). The
 1900 model also showed that avoided erosion and avoided sediment export are the highest in areas with pronounced terrain
 1901 and steep slopes, indicating that this ES is most important in those areas. While the SDR model gives plausible outputs,
 1902 its accuracy depends heavily on soil, evapotranspiration, and rainfall data. The coefficients we used are based on global
 1903 or European values, which should be adjusted to Armenian conditions and agricultural practices accurately.

1904 The SWY model predicted the highest baseflow values—155 and 137 mm—in alpine and subalpine grasslands, while
 1905 the forest zone showed a minimal baseflow of 29 mm, similar to that of the steppes (25 mm); both are lower than those
 1906 in the semidesert and desert zones (Section 3.1.B1). The proportion of baseflow contributed by ecosystems is also minimal
 1907 in the forest and steppe zones (89%). This counterintuitive result, in our view, is explained by the combined effects of
 1908 multiple factors that determine baseflow—precipitation, terrain slope, and soil permeability. Very high absolute baseflow
 1909 values in mountain grasslands result from the high precipitation in the mountains. In other mountainous regions, higher
 1910 baseflow values have also been found in upper elevation areas (e.g., Rumsey et al., 2015). The low baseflow values in the
 1911 forest zone are most likely the result of forests occurring predominantly on the steep slopes of gorges and mountains.
 1912 According to our assessment, the highest mean slope among the vegetation zones occurs in the forest and juniper zones
 1913 —about 20°, whereas mountain grasslands and steppes occupy gentler slopes from 10° to 17°, and the semideserts and
 1914 the single desert patch lie on plains with an average slope of about 6° (Fig. 3.5-1). The moderate baseflow of 38 mm and
 1915 the high proportion of it contributed by ecosystems (94%) in the semidesert zone are most likely due to its location in
 1916 areas with the gentlest relief and a high proportion of highly permeable soils. The only small desert patch remaining in
 1917 Armenia exhibits moderate baseflow of 34 mm an extremely high proportion of baseflow provided by ecosystems (98%),
 1918 probably because it is entirely located on soils with the highest permeability.

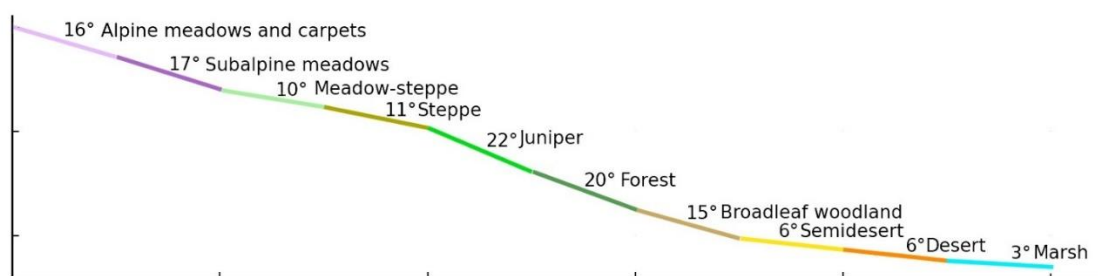

1919
 1920 *Figure 3.5-1. Average slope for vegetation zones (the zones are arranged by elevation for illustration only; in reality, the*
 1921 *elevation distribution may differ).*

1922 The recommended in the InVEST guide values of albedo and evapotranspiration used for modeling of cooling capacity
 1923 CC (Section 3.1.E), calculated that grasslands in dry zones is lower CC than that of bare soil, i.e. grasslands exert a weak
 1924 net warming effect. This result may seem counterintuitive; however, it is plausible in arid zones because
 1925 evapotranspiration from grasslands is minimal or absent during the dry season, and the albedo of dry bare soils can
 1926 exceed that of dried grass. Additionally, due to surface roughness, dry grass cools more slowly than bare ground. There
 1927 are examples of dry vegetation being warmer than bare soil from the tropical zone (Feldman et al., 2022) and from Central
 1928 Europe (Hesslerová et al., 2013). Nevertheless, this CC relationship for Armenia requires careful verification. Changing
 1929 any of the coefficients determining CC (evapotranspiration, albedo, and tree canopy cover (shade) can alter the ratio of
 1930 CC among different land cover classes. This highlights the need for model calibration.

⁵¹ <https://esdac.jrc.ec.europa.eu/content/global-soil-erosion>

⁵² https://ec.europa.eu/eurostat/statistics-explained/index.php?title=Agri-environmental_indicator_-_soil_erosion#Analysis_at_EU_and_country_level

⁵³ <https://www.fao.org/aquastat/en/countries-and-basins/country-profiles/country/ARM>

1931 Changes in ES were estimated as the result of land-cover changes. The overall 2.5% reduction in the extent of natural
 1932 ecosystems from 2017 to 2023 has led to a 0.5–2.7% reduction in the potential of all assessed ES (Table 3.5-3). These
 1933 data clearly show how changes in ecosystem extent directly affect both ES overall supply and their spatial distribution.
 1934 Such information is essential for planning and prioritizing measures that maintain or enhance ecosystem benefits for
 1935 communities and sectors across Armenia.

1936 *Table 3.5-3. Total changes in ES from 2017 to 2023*

<i>ES</i>	<i>Indicator</i>	<i>Absolute changes</i>	<i>Relative changes to 2017 value, %</i>
Baseflow provisioning	Baseflow volume, provided by ecosystems	-49.1 millions of m3	-2.2%
Preventing soil erosion	Avoided erosion	-1.18 Mt	-0.9%
Preventing sediment export	Avoided sediment export	-0.06 Mt	-0.5%
Flood mitigation	Runoff retention, provided by ecosystems	-2.79 millions of m3	-2.3%
Ecosystem effect on surface temperature	Cooling capacity	-0.002	-1%
Carbon storage	Carbon stock in ecosystems	-4.26 Mt	-2.7%
Fodder production	Carrying capacity of grasslands	-23600 LU	-2.1%

1937

1938
1939
1940
1941

3.6. Examples of accounting tables

ES of baseflow provision (Section 3.1.B2)

Table 3.1.B2-3. ES indicators across watersheds and vegetation types, millions of m3 (according to INKA recommendations)

		Alpine vegetation	Subalpine meadows	Meadow-steppe	Steppe	Grasslands in forest zone	Forests	Juniper	Broadleaf woodland	Semidesert	Desert	Marsh	Total in watersheds
Potential ES: baseflow volume provided by ecosystems	Aghstev	0.08	16.35	0.00	0.55	20.75	10.28	0.00	28.47	0.00	0.00	0.00	76.47
	Akhuryan	33.80	94.65	71.86	47.41	0.00	0.24	0.00	0.00	0.22	0.00	3.99	252.17
	Arpa	100.43	45.41	41.32	96.20	44.70	1.74	6.91	0.00	80.61	0.00	6.18	423.49
	Debed	17.19	185.76	66.66	25.53	44.09	11.22	0.00	1.88	0.00	0.00	1.37	353.69
	Hrazdan	41.83	47.49	41.32	25.97	43.32	2.44	0.00	0.08	12.69	0.00	0.94	216.07
	Metsamor	91.88	34.47	97.68	30.75	8.44	1.42	0.00	0.00	123.33	0.00	1.94	389.90
	Sevan	35.71	71.25	11.99	28.70	5.60	0.71	1.72	0.15	0.00	0.00	2.35	158.19
	Vorotan	100.63	67.45	25.75	49.61	44.26	11.69	0.57	21.12	19.90	0.00	0.81	341.79
Armenia	421.56	562.83	356.57	304.71	211.15	39.74	9.20	51.68	236.75	0.00	17.58	2211.78	
Baseflow demand	Aghstev	0.02	4.15	0.00	0.13	5.32	3.04	0.00	6.55	0.00	0.00	0.00	19.2
	Akhuryan	14.52	39.13	29.82	20.23	0.00	0.16	0.00	0.00	0.10	0.00	1.65	105.6
	Arpa	4.26	1.84	1.54	4.04	1.83	0.10	0.12	0.06	3.19	0.01	0.21	17.2
	Debed	0.96	9.55	3.53	1.32	2.38	0.89	0.00	0.10	0.00	0.00	0.08	18.8
	Hrazdan	83.65	93.94	83.09	54.63	87.27	7.36	0.00	0.17	26.11	0.00	1.97	438.2
	Metsamor	137.02	52.80	149.13	48.10	10.61	5.05	0.00	0.00	370.28	0.00	3.52	776.5
	Sevan	13.21	26.58	4.62	10.87	2.16	0.38	0.63	0.06	0.00	0.00	0.92	59.3
	Vorotan	25.86	17.82	6.78	13.29	11.74	3.53	0.15	5.26	4.88	0.00	0.21	89.5
Armenia	279.50	245.81	278.52	152.61	121.31	20.51	0.90	12.20	404.56	0.01	8.56	1524.3	
Actual flow (supply=use)	Aghstev	0.02	4.15	0.00	0.13	5.32	3.04	0.00	6.55	0.00	0.00	0.00	19.21
	Akhuryan	14.52	39.13	29.82	20.23	0.00	0.16	0.00	0.00	0.10	0.00	1.65	105.61
	Arpa	4.26	1.84	1.54	4.04	1.83	0.10	0.12	0.00	3.19	0.00	0.21	17.13
	Debed	0.96	9.55	3.53	1.32	2.38	0.89	0.00	0.10	0.00	0.00	0.08	18.81
	Hrazdan	41.83	47.49	41.32	25.97	43.32	2.44	0.00	0.08	12.69	0.00	0.94	216.07
	Metsamor	91.88	34.47	97.68	30.75	8.44	1.42	0.00	0.00	123.33	0.00	1.94	389.90
	Sevan	13.21	26.58	4.62	10.87	2.16	0.38	0.63	0.06	0.00	0.00	0.92	59.42
	Vorotan	25.86	17.82	6.78	13.29	11.74	3.53	0.15	5.26	4.88	0.00	0.21	89.52
Armenia	192.54	181.02	185.29	106.60	75.19	11.95	0.90	12.05	144.19	0.00	5.95	915.68	
Unused potential/ unmet demand	Aghstev	0.06	12.20	0.00	0.42	15.43	7.24	0.00	21.92	0.00	0.00	0.00	57.26
	Akhuryan	19.28	55.52	42.04	27.18	0.00	0.08	0.00	0.00	0.12	0.00	2.34	146.56
	Arpa	96.17	43.57	39.78	92.16	42.87	1.64	6.79	-0.06	77.42	-0.01	5.97	406.29
	Debed	16.23	176.21	63.13	24.21	41.71	10.33	0.00	1.78	0.00	0.00	1.29	334.88
	Hrazdan	-41.82	-46.46	-41.77	-28.66	-43.95	-4.92	0.00	-0.09	-13.42	0.00	-1.03	-222.13
	Metsamor	-45.14	-18.33	-51.45	-17.35	-2.17	-3.63	0.00	0.00	-246.95	0.00	-1.58	-386.61
	Sevan	22.51	44.68	7.36	17.84	3.44	0.34	1.09	0.09	0.00	0.00	1.43	98.76
	Vorotan	74.77	49.63	18.97	36.32	32.52	8.16	0.42	15.86	15.02	0.00	0.60	252.27
Armenia	142.06	317.02	78.05	152.11	89.84	19.23	8.29	39.49	-167.81	-0.01	9.02	687.29	

1942
1943
1944

Table 3.1.B2-4. Supply-use table for ES of baseflow maintenance in format recommended by SEEA EA. The figures in parentheses indicate the volumes of water use that exceed the supplied ES, i.e., unmet demand.

		Drinking	Industrial, domestic and construction	Agriculture, fish, breeding and forestry	Total ES use	Alpine vegetation	Subalpine meadows	Meadow-steppe	Steppe	Grasslands in forest zone	Forests	Juniper	Broadleaf woodland	Semidesert	Desert	Marsh	Total ES supply
Aghstev	Supply					0	4	0	0	5	3	0	7	0	0	0	19
	Use	8	1	10	19												
Akhuryan	Supply					15	39	30	20	0	0	0	0	0	0	2	106
	Use	8	2	96	106												
Arpa	Supply					4	2	2	4	2	0	0	0	3	0	0	17
	Use	2	1	14	17												
Debed	Supply					1	10	4	1	2	1	0	0	0	0	0	19
	Use	10	4	5	19												
Hrazdan	Supply					42	47	41	26	43	2	0	0	13	0	1	216
	Use	28	19	169	216												
	Demand	57 (13%)	41 (9%)	341(78%)	438												

Metsamor	Supply					92	34	98	31	8	1	0	0	123	0	2	390
	Use	12	12	367	390												
	Demand	23 (3%)	21 (3%)	733(94%)	777												
Sevan	Supply					13	27	5	11	2	0	1	0	0	0	1	59
	Use	12	1	46	59												
Vorotan	Supply					26	18	7	13	12	4	0	5	5	0	0	90
	Use	7	63	19	90												
Armenia	Supply					193	181	185	107	75	12	1	12	144	0	6	916
	Use	46	55	815	916												
	Demand	133 (5%)	140 (6%)	2150 (89%)	2422 (100%)												

1945

Table 3.1.B3-3. Accounting table for the ES capacity for 2017 and 2023

	Alpine vegetation	Subalpine meadows	Meadow-steppe	Steppe	Grasslands in forest zone	Forests	Juniper	Broadleaf woodland	Semidesert	Desert	Marsh
Opening ES capacity in 2017	427.94	559.06	397.81	326.59	199.51	32.80	9.01	49.74	247.85	0.00	14.21
Additions to ES capacity	1.24	10.00	4.94	11.59	18.81	2.31	0.15	4.01	19.27	0.00	1.08
Managed expansion	NA										
Unmanaged expansion	NA										
Reductions in ES capacity	0.79	10.90	40.51	24.23	15.55	3.70	0.09	4.91	20.36	0.00	1.46
Managed reductions	NA										
Unmanaged reductions	NA										
Net change in ES capacity	0.44	-0.90	-35.57	-12.64	3.27	-1.39	0.07	-0.91	-1.09	0.00	-0.37
Closing ES capacity in 2024	428.39	558.16	362.24	313.96	202.78	31.41	9.08	48.84	246.76	0.00	13.84
Additional row											
Closing ES capacity in 2024 of eco-systems unconverted since 2017	427.15	548.16	357.30	302.37	183.97	29.10	8.93	44.83	227.49	0.00	12.75

1946

1947

1948

ES of prevention of erosion and sediment export to streams (Section 3.1.C2)

Table 3.1.C2-2. Accounting table for the ES potential changes

	Value of per-ha ES provisioning used	Alpine vegetation	Subalpine meadows	Meadow-steppe	Steppe	Grassl. in forest zone	Forests	Juniper	Broadleaf woodland	Semi-desert	Desert	Marsh	Total	
Avoided erosion, Mt/year	Opening ES capacity in 2017	2017	9.27	26.24	10.53	26.66	21.18	36.08	0.89	5.02	5.74	0.01	0.38	142.00
	Additions to ES capacity	2023	0.03	0.47	0.14	0.97	2.02	2.55	0.02	0.39	0.45	0.00	0.03	7.07
	Managed/unmanaged	NA												
	Reductions ES capacity	2017	0.02	0.51	1.07	1.98	1.65	4.07	0.01	0.50	0.47	0.00	0.04	10.31
	Managed/unmanaged	NA												
	Net change ES capacity	2023	0.01	-0.04	-1.00	-1.06	0.35	-1.54	0.01	-0.09	-0.03	0.00	-0.01	-3.40
	Closing ES capacity in 2023	2023	9.33	26.52	10.18	26.24	21.76	34.75	0.90	4.77	5.77	0.01	0.38	140.61
Additional row														
Closing ES capacity in 2023 of ecosystems unconverted since 2017,	2023	9.30	26.04	10.04	25.27	19.74	32.20	0.89	4.38	5.32	0.01	0.35	133.54	
Avoided sediment export, Mt/year	Opening ES capacity in 2017	2017	0.844	2.966	1.072	2.817	1.977	1.227	0.105	0.510	0.608	0.001	0.044	0.844
	Additions to ES capacity	2023	0.002	0.054	0.014	0.102	0.193	0.088	0.002	0.039	0.047	0.000	0.003	0.002
	Managed/unmanaged	NA												
	Reductions ES capacity	2017	0.002	0.058	0.109	0.209	0.154	0.138	0.001	0.050	0.050	0.000	0.004	0.002
	Managed/unmanaged	NA												
	Net change ES capacity	2023	0.001	-0.005	-0.102	-0.111	0.034	-0.053	0.001	-0.009	-0.003	0.000	-0.001	0.001
	Closing ES capacity in 2023	2023	0.800	2.990	1.041	2.765	2.084	1.203	0.107	0.475	0.600	0.001	0.043	0.800
Additional row														
Closing ES capacity in 2023 of ecosystems unconverted since 2017,	2023	0.797	2.937	1.027	2.663	1.891	1.114	0.105	0.436	0.553	0.001	0.040	0.797	

1949
1950

Table 3.1.C3-2. Supply-use table for ES of prevention of sediment export to streams. Sediment amount in water use, prevented by ecosystems, Mt

Watershed		Drinking	Industrial, domestic and construction	Agriculture, fish breeding and forestry	Total	Total ES supply by all ecosystems
Aghstev	ES supply					0.100
	ES use	0.043	0.007	0.050	0.100	
Akhuryan	ES supply					0.093
	ES use	0.007	0.002	0.085	0.093	
Arpa	ES supply					0.032
	ES use	0.004	0.001	0.026	0.032	
Debed	ES supply					0.040
	ES use	0.020	0.009	0.011	0.040	
Hrazdan	ES supply					0.353
	ES use	0.046	0.033	0.274	0.353	
Metsamor	ES supply					0.483
	ES use	0.014	0.013	0.456	0.483	
Sevan	ES supply					0.143
	ES use	0.029	0.002	0.111	0.143	
Vorotan	ES supply					0.211
	ES use	0.017	0.148	0.045	0.211	
Armenia	ES supply					1.455
	ES use	0.181	0.216	1.057	1.455	

1951

1952

ES of flood risk mitigation (Section 3.1.D2)

1953

Table 3.1.D2-2. Accounting table for the changes in ES potential

	Alpine vegetation	Subalpine meadows	Meadow-steppe	Steppe	Grassl. in forest zone	Forests	Juniper	Broadleaf woodland	Semi-desert	Desert	Marsh	Total
Opening ES capacity in 2017	9.32	23.92	13.37	26.95	15.49	15.21	0.80	2.87	12.76	0.05	0.95	121.69
Additions to ES capacity	0.03	0.43	0.17	0.96	1.46	1.07	0.01	0.23	0.99	0.00	0.07	5.42
Managed/unmanaged	NA											
Reductions ES capacity	0.02	0.47	1.36	2.00	1.21	1.72	0.01	0.28	1.05	0.00	0.10	8.21
Managed/unmanaged	NA											
Net change ES capacity	0.01	-0.04	-1.20	-1.04	0.25	-0.64	0.01	-0.05	-0.06	0.00	-0.02	-2.79
Closing ES capacity in 2023	9.33	23.89	12.18	25.90	15.75	14.57	0.80	2.82	12.71	0.05	0.92	118.91
Closing ES capacity in 2023 of ecosystems unconverted since 2017	9.30	23.46	12.01	24.95	14.29	13.50	0.79	2.59	11.71	0.05	0.85	113.49

1954

1955

ES of carbon storage in soil and tree biomass (Section 3.1.G)

1956

Table 3.1.G2-1. Accounting table for the changes in ES potential

	Alpine vegetation	Subalpine meadows	Meadow-steppe	Steppe	Grassl. in forest zone	Forests		Juniper	Broadleaf woodland	Semi-desert	Desert	Marsh	Total
						C in soil	C in wood						
Opening ES capacity in 2017	10.48	27.71	18.29	31.65	16.63	19.81	15.74	0.73	3.45	9.46	0.02	1.17	155.14
Additions to ES capacity	0.03	0.50	0.23	1.12	1.57	1.39	1.11	0.01	0.28	0.74	0.00	0.09	7.06
Managed/unmanaged	NA												
Reductions ES capacity	0.02	0.54	1.86	2.35	1.30	2.23	1.78	0.01	0.34	0.78	0.00	0.12	11.32
Managed/unmanaged	NA												
Net change ES capacity	0.01	-0.04	-1.64	-1.22	0.27	-0.84	-0.67	0.01	-0.06	-0.04	0.00	-0.03	-4.26
Closing ES capacity in 2023	10.49	27.66	16.65	30.43	16.90	18.97	15.08	0.74	3.39	9.42	0.02	1.14	150.88

1957

1958

1959
1960

ES of fodder production in natural pastures and hayfields (Section 3.2.A)

Table 3.2.A2-1. Accounting table for ES capacity changes

	Alpine vegetation	Subalpine meadows	Meadow-steppe	Steppe	Grassl. in forest zone	Juniper	Broadleaf woodland	Semi-desert
Opening ES capacity in 2017	72420.92	391341.9	179012.6	239502.6	179562	5666.32	31267.72	37177.95
Additions to ES capacity	209.44	6997.9	2223.27	8496.84	16932.51	95.48	2518.12	2890.65
Managed/unmanaged	NA							
Reductions ES capacity	134.2	7629.44	18229.68	17765.44	13992.93	54.56	3088.8	3054.3
Managed/unmanaged	NA							
Net change ES capacity	75.24	-631.54	-16005.8	-9269.04	2939.58	40.92	-570.68	-163.8
Closing ES capacity in 2023	72496.16	390710.3	163006.8	230234	182501.6	5707.24	30697.48	37014.15
Additional row								
Closing ES capacity in 2023 of ecosystems unconverted since 2017	72286.72	383712.4	160782.9	221737.1	165569	5611.76	28178.92	34123.65

1961
1962

Table 3.2.A3-3. Supply-use table

		Agriculture	Total ES supply
Aragatsotn	ES supply		40.6
	ES use	40.6	
Ararat	ES supply		31.9
	ES use	31.9	
Armavir	ES supply		6.73
	ES use	6.73*	
Gegharkunik	ES supply		53.9
	ES use	53.9	
Kotayk	ES supply		28
	ES use	28	
Lori	ES supply		40.7
	ES use	40.7	
Shirak	ES supply		45.1
	ES use	45.1	
Syunik	ES supply		28.2
	ES use	28.2	
Tavush	ES supply		17.3
	ES use	17.3	
Vayots Dzor	ES supply		10.3
	ES use	10.3	
Armenia	ES supply		339.7
	ES use	339.7	

1963
1964

Table 3.4-1. Supply-use table for all ES with assessed use

		Drinking	Industrial, domestic and construction	Agriculture, fish breeding and forestry	Total ES use	Alpine vegetation	Subalpine meadows	Meadow-steppe	Steppe	Grasslands in forest zone	Forests	Juniper	Broadleaf woodland	Semidesert	Desert	Marsh	Total ES supply
Baseflow provisioning	Supply					193	181	185	107	75	12	1	12	144	0	6	916
	Use	46	55	815	916												
	Demand	133 (5%)	140 (6%)	2150 (89%)	2422 (100%)												
Preventing sediment export	ES supply																1.45
	ES use	0.181	0.216	1.057	1.455												5
Forage and fodder production	ES supply																339.7
	ES use			339.7													7

1965

4. Contribution to Global Biodiversity Framework

The EA PV1 makes a direct informational contribution to Targets 1, 3, 11, 14 and 21, as well as Goals A and B of the Global Biodiversity Framework (<https://www.gbf-indicators.org/>) and indirectly contributes to other GBF targets by providing an informational basis for management and educational efforts (Figure 4-1; Table 4-1).

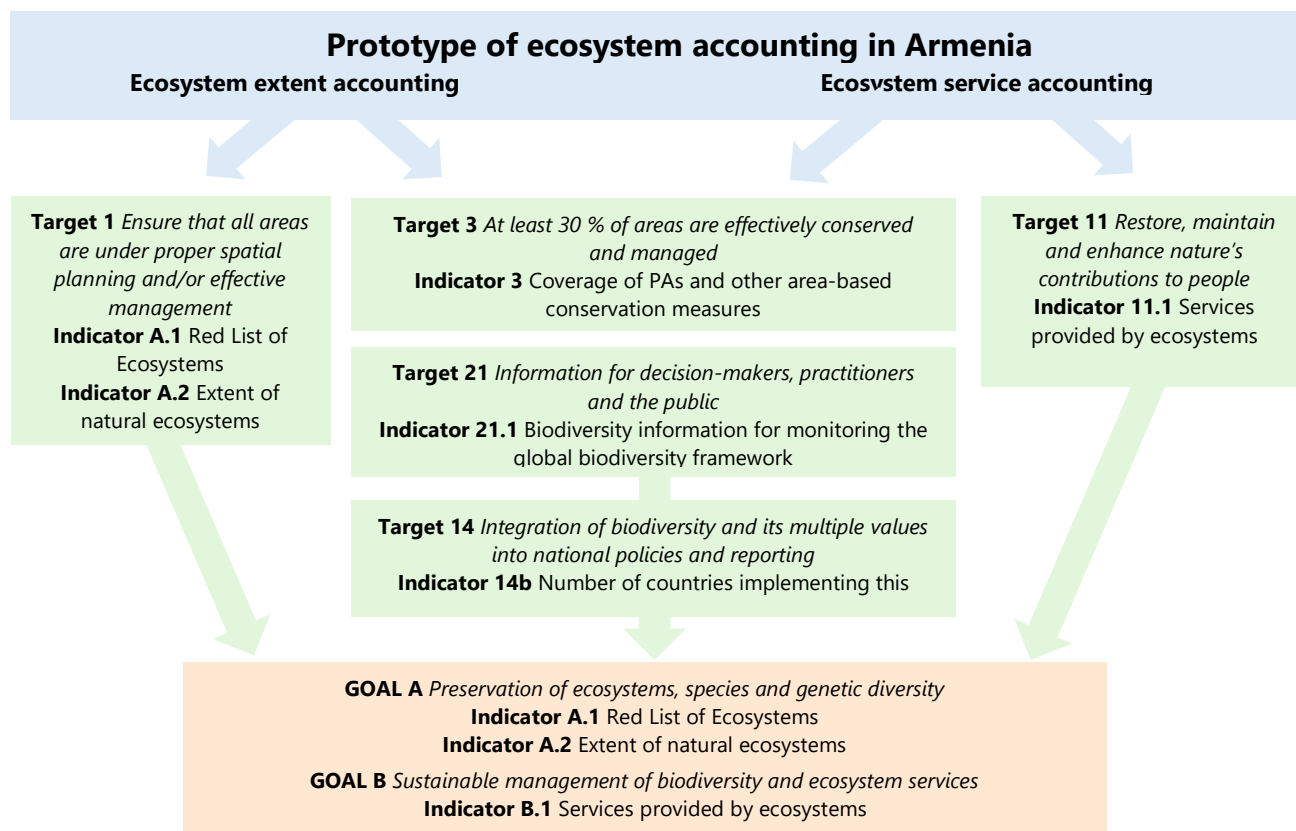

Figure 4-1. GBF goals and targets related to the EA PV1.

Table 4-1. Contribution of EA PV1 to achieving GBF goals and targets

Target	Indicator	EA Prototype V1 contribution
1. Ensure that all areas are under participatory, integrated and biodiversity inclusive spatial planning and/or effective management processes addressing land- and sea-use change, to bring the loss of areas of high biodiversity importance, including ecosystems of high ecological integrity, close to zero by 2030, while respecting the rights of indigenous peoples and local communities	A.1. Red List of Ecosystems	Assessed criteria of ecosystems for RLE (Section 2.3): - Rarity ranking and rarity maps of ecosystems - Trends in ecosystem extent
	A.2. Extent of natural ecosystems	Extent accounting for the following natural ecosystem types (Section 2.3): - Alpine ecosystems - Subalpine ecosystems - Meadow-steppe - Steppe - Grasslands in forest zone - Forests - Juniper woodlands - Broadleaf woodlands - Semidesert - Desert - Marches
3. Ensure and enable that by 2030 at least 30 per cent of terrestrial and inland water areas, and of marine and coastal areas, especially areas of particular	3.1 Coverage of protected areas and other	Data of ecosystem accounting supporting informed decision-making on the development of protected area networks:

<p>importance for biodiversity and ecosystem functions and services, are effectively conserved and managed through ecologically representative, well-connected and equitably governed systems of protected areas and other effective area-based conservation measures, recognizing indigenous and traditional territories, where applicable, and integrated into wider landscapes, seascapes and the ocean, while ensuring that any sustainable use, where appropriate in such areas, is fully consistent with conservation outcomes, recognizing and respecting the rights of indigenous peoples and local communities, including over their traditional territories</p>	<p>effective area-based conservation measures</p>	<ul style="list-style-type: none"> - rarity of terrestrial ecosystem types (Sections 2.3.B; 2.5.A); - degree of anthropogenic transformation of landscapes (Section 2.4.A); - changes in ecosystem extent (Sections 2.3.C; 2.4.B; 2.5.C); - importance of marzes for the conservation of ecosystem diversity in Armenia (Sections 2.4.D and 2.5.B)
<p>11. Restore, maintain and enhance nature’s contributions to people, including ecosystem functions and services, such as the regulation of air, water and climate, soil health, pollination and reduction of disease risk, as well as protection from natural hazards and disasters, through nature-based solutions and/or ecosystem-based approaches for the benefit of all people and nature</p>	<p>11.1. Services provided by ecosystems</p>	<p>Accounting for the ES provided by ecosystems (Section 3):</p> <ul style="list-style-type: none"> - Production of forage and fodder by natural grasslands - Wild plants biomass provisioning: edible, culinary and medicinal plants - Nectar production by wild plants for honeybees to produce honey - Global climate regulation: Storage of carbon in ecosystems in soil and tree biomass - Local climate regulation: Effect of natural ecosystems on surface temperature (cooling effect) - Prevention of soil erosion; - Prevention of ediment export to streams - Water flow regulation: Baseflow provisioning - Flood risk mitigation - Crop pollination by wild insects - Natural conditions for recreation: hiking in Pas - Importanse of biodiversity for Armenian culture
<p>14. Ensure the full integration of biodiversity and its multiple values into policies, regulations, planning and development processes, poverty eradication strategies, strategic environmental assessments, environmental impact assessments and, as appropriate, national accounting, within and across all levels of government and across all sectors, in particular those with significant impacts on biodiversity, progressively aligning all relevant public and private activities, and fiscal and financial flows with the goals and targets of this framework.</p>	<p>14.b. Number of countries integrating biodiversity and its multiple values into policies, regulations, planning, development processes, poverty reduction strategies and accounts at all levels, across all sectors.</p>	<p>Ecosystem accounting prototype V1 supports informed decision-making in the following policy areas related to environment (see Summary):</p> <ul style="list-style-type: none"> - integration of ecosystem values into economic and environmental decision-making; - informed biodiversity conservation decision-making; - land-use planning and sustainable ecosystem use to maintain ecosystem services; - land-use planning for climate change mitigation; - land-use planning for natural hazard risk reduction; - considering impacts of land use on ecosystem services; - international reporting and integration
<p>21. Ensure that the best available data, information and knowledge are accessible to decision makers, practitioners and the public to guide effective and equitable governance, integrated and participatory management of biodiversity, and to strengthen communication, awareness-raising, education, monitoring, research and knowledge management and, also in this context, traditional knowledge, innovations, practices and technologies of indigenous peoples and local communities should only be accessed with their free, prior and informed consent, in accordance with national legislation</p>	<p>21.1. Indicator on biodiversity information for monitoring the global biodiversity framework</p>	<p>Data on Ecosystem Extent and Ecosystem Services (maps, national and marz indicators, changes from 2017 to 2023)</p>

5. Data and methodological gaps and recommendations

5.1. Data and methods for ecosystem extent accounting

5.1.A. Land cover data

Accurate and regularly updated land-cover data are a key prerequisite for reliable ecosystem accounting. Extent accounting for land-cover classes (Section 2.2) is necessary for:

- identifying areas of natural land-cover classes excluding croplands and built-up areas, that is, identifying natural non-woody ecosystems and their extent, as well as identifying tree cover as forest and woodland ecosystems (Sections 2.3; 2.4; 2.5);
- tracking changes in the area of natural non-woody ecosystems as they transition to croplands and built-up areas, and vice versa, as well as tracking changes in tree cover extent (Section 2.3.C);
- assessing the degree of anthropogenic transformation of different EEAs — marzes (Section 2.2.B1), vegetation zones (2.3.A), landscape zones, and PAs (Section 2.6.B);
- mapping, GIS-based assessment, and modelling of ES (Section 3).

Currently, Armenia does not have a refined national land-cover dataset that is regularly updated. Testing of available global datasets to select one for the methodological demonstration of ecosystem accounting showed that four datasets most closely represent Armenia’s land cover: Dynamic World, Esri, ESA, and GLAD. However, their total discrepancy from Government-reported land-cover class areas across marzes ranges from 19.4% to 20.9% of Armenia’s total area (Section 2.1). For use in EA Prototype V1, the Esri dataset was selected, as it is sufficiently accurate and allows us to demonstrate changes in EE and ES between 2017 and 2023.

The used Esri land cover data have discrepancy with government-reported data of 19.4% relative to the total area of Armenia (Section 2.1.A). The accuracy of global land cover datasets does not exceed 75% (Venter et al., 2022) or 84% (Xu et al., 2024). For countries with many primary sampling units (at least 100), the accuracy of the ESA World Cover—identified by the cited authors as the most accurate—ranges from 66% to 98% (Xu et al., 2024) with an average of around 80%. Although we cannot directly compare these figures to our estimates due to methodological differences, 80.6% match in land cover class areas at the province level in Armenia provides a reasonable justification for using the Esri land cover dataset for the national-scale scoping EA.

Obviously, global land cover datasets are not suitable for ecosystem accounting (both EE and ES) in smaller EAA, such as municipalities or small PAs, which require more precise land cover data.

The accuracy of land-cover data is particularly important for accounting rare ecosystems with small area. This is illustrated by the fact that the Esri and ESA datasets, tested using LLSS as an example, yield broadly similar results for common LLSS types, but the ranking of LLSS by rarity and of marzes by their importance for conservation LLCC diversity differs substantially when the rarest LLSS types are included in the assessment (Section 2.5).

Also, even small total-area errors in land cover data, or changes in the algorithms used to classify land cover types, can result in significant distortions in the assessment of land cover change — especially when the actual changes are small in absolute terms, as is the case in Armenia (Section 2.2.B2). Since changes in EE and in ES are driven by changes in land cover, inaccuracies in land-cover data lead directly to errors in these assessments.

Among the most evident land-cover errors are the misclassification of croplands and built-up areas in high-elevation regions. Such errors have the strongest impact on EA results for small EEA units, such as PAs and natural monuments. Examples are provided in Sections 2.6 and 3.1.I.

Therefore, a first and crucial step toward launching national EA should be the development of a national land cover dataset, verified using ground-based data collected specifically within the country. The classes of the national land-cover dataset should be harmonized with the official land-cover area statistics (in particular, including a shrubland class). In addition, to support accurate EE accounting, it is necessary to distinguish two tree-cover classes: closed forest and open woodland. For croplands, it is highly desirable to distinguish between actively used and abandoned arable land, as well as perennial plantations.

2023 **5.1.B. Harmonization ecosystem extent accounting with the Government-reported land-cover accounting** 2024 **data**

2025 Accounting by land-cover classes delineated in accordance with the Government of RA Decision on land-cover
2026 classification⁵⁴ can be carried out on the basis of Government-reported data, which have been publicly available for
2027 Armenia as a whole and by marzes since 2020 (Section 2.2.A). These official statistics provide the most established
2028 national classification of land cover. However, these data do not include digital land-cover maps, so they cannot be used
2029 for ecosystem-service modelling and mapping. The absence of maps also prevents the construction of a land-cover
2030 transition matrix and the assessment of additions and reductions by land-cover classes over the reporting period, as
2031 recommended by the SEEA EA (Section 2.2.A)

2032 To launch national ecosystem accounting, it is necessary to harmonize it with the official land-cover accounting data.
2033 To harmonize Government-reported data on land-cover class extents with other SEEA EA data and satellite-derived data,
2034 a decision is needed on how to reclassify vegetation-free areas, grasslands, and cultivated lands located both within and
2035 outside settlement boundaries.

2036 A significant challenge is the harmonization of the official approach to defining areas covered by shrubs with the
2037 methods of identification of such areas from satellite imagery. At this stage, we did not use this land-cover class in our
2038 assessments, as testing of the available land cover datasets revealed very large discrepancies in the delineation of shrub-
2039 covered areas (Section 2.1.A).

2040 **5.1.C. Detailed ecosystem map**

2041 Accounting for the extent of land-cover classes alone is not sufficient for addressing Armenia's biodiversity
2042 conservation needs. Land cover classes do not reflect the diversity of Armenia's ecosystems, because the same land-
2043 cover type—grasslands, for example—can correspond to very different ecosystems, such as alpine and subalpine
2044 meadows, various steppe types, semi-deserts and deserts.

2045 A national ecosystem map is essential for biodiversity conservation, as it provides a consistent spatial basis for
2046 identifying rare, threatened and priority ecosystems. EA Prototype V1 uses a generalized vegetation map developed by
2047 the project experts on the basis of previous long-term studies by Armenian geobotanists.

2048 To determine the extent of natural ecosystems and to track their changes, we intersected this map with the land-
2049 cover data. (a) Anthropogenic areas (croplands and built-up areas) were excluded from the extent of natural ecosystems;
2050 (b) tree cover identified in the Esri dataset was interpreted as forests. This approach was also tested using landscape
2051 zones and LLSS as examples and demonstrated its effectiveness. We recommend it for further EE accounting.

2052 To enable more accurate ecosystem accounting for biodiversity conservation purposes, as well as a more precise
2053 assessment of the role of ecosystems in providing ES, we recommend further refinement of the ecosystem map based
2054 on the conceptual approach Ecological Land Units (ELU), defining the correspondence between vegetation community
2055 types and environmental factors – topography, climate (precipitation, temperature, seasonality), soils, and geology.
2056 Linking ecosystem types to environmental factors will allow ecosystem role in providing ES to be represented more
2057 accurately, since ES models are based precisely on these environmental factors. This will reduce the risk of systematic
2058 bias in assessing the role of different terrestrial ecosystems in ES provisioning.

2059 Based on the available data on tree cover and its density, it would be desirable to produce a layer distinguishing
2060 between closed forests and open woodlands, as open woodlands are important ecosystems for Armenia.

2061 This approach will make it possible to develop a detailed map of ecosystem types by GIS-based methods, if they have
2062 sufficient area to be represented at the scale of the maps and land-cover data used.

2063 At subsequent stages of developing ecosystem accounting, it will be useful to develop a catalogue and a map of unique
2064 point ecosystems. This work can only be carried out on the basis of field survey data.

2065 **5.2. Ecosystem condition accounting**

2066 Ecosystem condition is a key component of ecosystem accounting, encompassing indicators of ecosystem structure,
2067 composition, and function, as well as negative indicators such as pollution, anthropogenic disturbance and degradation.
2068 However, at this stage, these indicators were not included in the EA PV1, as consistent and spatially explicit data covering
2069 the entire territory of Armenia are not yet available.

2070 EA PV1 incorporates only one preliminary example illustrating how the degree of land degradation affects the ES of
2071 grazing biomass production by natural grasslands (Section 3.2.A3). In this example, accounting for degraded land
2072 increases the share of used pasture carrying capacity across marzes by 1–16% (from 23% to 39% in Tavush marz). It is
2073 evident that taking ecosystem conditions into account will also have a strong impact on the assessment of other ES.

⁵⁴ Decision No. 431-N of 11 April 2019 of the Government of the Republic of Armenia on approving the procedure for the classification of the land cover of the Republic of Armenia

2074 Valuable information for assessing ecosystem quality can be obtained from transition matrices showing conversions
 2075 of ecosystems to anthropogenic areas (croplands and built-up areas) and back (Section 2.3.C). Areas that have only
 2076 recently been released from crop cultivation or built-up functions clearly have a reduced potential to provide ES and to
 2077 support biodiversity. We therefore recommend transition matrices and additional indicators “extent of unconverted
 2078 ecosystems” and “time since abandonment” be taken into account both in ES assessment and in assessing the
 2079 conservation value of areas for biodiversity.

2080 **5.3. Data and methods for ecosystem service accounting**

2081 **5.3.A. Data limitations for ES assessment**

2082 The absence of publicly available data on forestry and hunting management did not allow us to assess the
 2083 corresponding ES. At present, the open Armstat data includes only two types of information that allow us to assess ES
 2084 use: data on water use and the number of livestock heads by marz. This data made it possible to assess the use of the ES
 2085 of baseflow provision and prevent sediment export in streams. Lack of recent scientific studies on the productivity and
 2086 exploitable stocks of wild edible and medicinal plants, as well as the absence of data on harvesting intensity, did not allow
 2087 us to assess the level of use of the corresponding ES. The planned launch of such studies under targeted funding in the
 2088 coming years may help resolve this problem.

2089 The accuracy of data on natural conditions is critical for GIS-based ES assessment and modelling and, consequently,
 2090 for ES accounting. In this scoping study, digital elevation model, climate data, reference evapotranspiration, Kc
 2091 coefficients for crops and vegetation, and albedo values were obtained from global databases which accuracy at the
 2092 national scale may vary due to spatial interpolation and the resolution of source station networks. We recommend that
 2093 ES modeling for national ecosystem accounting be based on data verified using *in situ* measurements from Armenia’s
 2094 hydrometeorological, geodesy, and cartography services.

2095 The spatial resolution of the data used should be consistent with the scale of EAAs. Coarse-resolution raster data are
 2096 not suitable for assessing small EAAs, such as small PAs. In the Prototype, this limitation became evident in the example
 2097 of carbon stock assessment for the Sev Lich sanctuary, where large zero-carbon pixels corresponding to the lake areas in
 2098 the low-resolution (250 m) soil-carbon map resulted in a significant underestimation of carbon stocks in this PA (Section
 2099 3.1.I).

2100 **5.3.B. Assessment of the balance between ES potential, demand, and use**

2101 SEEA EA recommendations include in ES accounting tables two indicators — ES supply and ES use — which are
 2102 required to be equal in order to maintain the accounting balance. These indicators are included in the example ES
 2103 accounting tables in EA Prototype V1 (Section 3.4).

2104 However, these indicators of actual ES flow are insufficient for informing decisions on ecosystem use, because the
 2105 equality of supply and use in the accounting tables masks critical information about ES potential/capacity, sustainability
 2106 thresholds in ES use, unmet demand in ES, and ES overuse. Decision-makers need indicators that reveal whether ES are
 2107 being used within sustainable capacity, where shortages occur, and how ES use affects long-term ecosystem functioning.
 2108 We therefore recommend using, alongside the SEEA EA recommendations, the indicators proposed by the INCA project
 2109 (examples included in EA Prototype V1 are given in parentheses):

- 2110 - ES potential/capacity (baseflow provision, Section 3.1.B; preventing soil erosion and sediment export to streams,
 2111 Section 3.1.C; flood risk mitigation, Section 3.1.D; cooling effect, Section 3.1.E; forage and fodder production,
 2112 Section 3.2.A; recreational conditions for hiking (Section 3.3);
- 2113 - Demand in ES and unmet demand (baseflow provision, Section 3.1.B);
- 2114 - ES overuse (forage/fodder production, Section 3.2.A);
- 2115 - Unused ES potential, use-to-potential ratio (baseflow provision, Section 3.1.B).

2116 **5.3.C. Challenges in assessing ES supply across different ecosystems**

2117 At this stage, it was possible to assess the supply-use volume for only three ES (forage/fodder production, Section
 2118 3.2.A3; baseflow provisioning, Section 3.1.B2; prevention of sediment export, Section 3.1.C3). Moreover, this could be
 2119 done directly only for all ecosystems together. It was not possible to directly assess the supplied ES by ecosystem type,
 2120 because we did not have data on what share of the potential ES of each ecosystem type is actually supplied/used. For
 2121 the ES of forage/fodder provision we do not know how livestock are distributed across ecosystem types, for water-related
 2122 ES we do not know what volume of water flow originates from the areas of different ecosystem types. To assume that
 2123 livestock are evenly distributed across different ecosystem types and that different ecosystems generate the same water
 2124 flow would be an unacceptable oversimplification. We were able to assess the contribution of different ecosystems to

2125 water flow generation only for the ES of baseflow provision, and only by using multi-step indirect calculations (Section
2126 3.1.B2). Such a method is a potential source of amplified errors, and we do not recommend using it.

2127 **5.3.D. Integration scoping-level and detailed ES models**

2128 At the scoping stage, the InVEST models used for water-related ES modelling proved useful for demonstrating general
2129 approaches to integrating ES assessments and maps into Armenia’s ecosystem accounting. However, InVEST tool does
2130 not reflect the diversity of natural conditions in Armenia.

2131 The SWY model does not account for snow accumulation and melt, which is a major factor in Armenia’s highland
2132 hydrology. The approach we used in this study ignores snow sublimation and local variations in melt timing. For a more
2133 accurate assessment, it is clearly necessary to incorporate specialized models, such as SNOW-17, which can significantly
2134 improve runoff predictions (Scordo et al., 2018). Another significant limitation is the lack of accounting for geological
2135 structure, which is important for baseflow assessment.

2136 Modeling the ES of flood risk mitigation (UFRM model) showed meaningful ecosystem effects only under an extreme
2137 rainfall scenario (50 mm). For average spring rainfall (12 mm), the model barely registered any difference between
2138 current land cover and the bare ground scenario, which is due to low amounts of precipitation. It suggests the model may
2139 not be picking up more subtle but still important differences in landscape runoff retention under typical rainfall events.
2140 That raises questions about the model’s sensitivity under more typical weather conditions. Moreover, the UFRM model
2141 accounts only for the water retention capacity of ecosystems but does not consider water flow across the terrain, which
2142 makes it poorly suited for the mountainous conditions of Armenia. Slope has a critical impact on the rate of water runoff,
2143 which is why topography must be taken into account—as was done, for example, in (Vallecillo et al., 2020).

2144 The coefficients used to model cooling capacity of ecosystems also require local calibration (Section 3.5).

2145 These issues point to a clear need for InVEST model calibration (i.e., adjusting the model to match observed local
2146 data) before using its output in ecosystem accounts. According to (Ochoa et al., 2017), among the publications that used
2147 SWAT, 79% carried out some form of calibration, whereas for InVEST, only 13% of the studies did so. However, calibrated
2148 InVEST models can provide a sufficiently reliable ES assessment for strategic decision-making (Halder et al., 2022; Hamel
2149 et al., 2020). Our experience shows that InVEST models can be useful at the scoping stage, a necessary step before
2150 initiating ecosystem accounting.

2151 More accurate ES assessment and mapping across the entire territory of Armenia, essential for informed decision-
2152 making, are hindered because some important coefficients in InVEST models are assigned single values, either for the
2153 entire area (the number of rainy days in the SWY and UFRM models) or for broad land cover classes (Kc in the SWY
2154 model), assuming that land-cover classes are uniform across the assessment area. As a result, models do not account for
2155 differences among areas at varying elevations or across climatic zones within Armenia.

2156 Thus, at the preliminary stage, InVEST models proved useful for demonstrating general approaches to integrating ES
2157 assessments and maps into Armenia’s ecosystem accounting. However, given the aforementioned model uncertainties
2158 and simplifications, the estimates we obtained should be regarded as ES proxies rather than reliable data for
2159 management decisions or monetary valuation and should not be used directly in national accounting without proper
2160 calibration.

2161 As ecosystem accounting and the corresponding data collection system develop, it may become reasonable to
2162 transition to the use of hydrological and climatic models that account for a greater number of processes and local data.
2163 However, this requires another milestone in Armenia, namely the open access to such data. At later stages, it is advisable
2164 to use different models for different purposes and decision-making contexts. InVEST models can be applied for rapid and
2165 simplified ecosystem service modeling to obtain a general overview. SWAT and other detailed hydrological and climate
2166 models are necessary for producing high-resolution and accurate assessments. Decision-support models (such as RIOS,
2167 AQUATOOL, and others) are useful for the practical application of ecosystem service assessments and maps in
2168 management contexts (Lüke and Hack, 2017, Momblanch et al., 2017; Vogl et al., 2017).

2169 At subsequent stages of developing ES accounting, it would be useful to include models of ES changes driven by
2170 climate change.

2171 **5.3.E. Potential bias in assessing the role of different terrestrial ecosystems in ES provisioning**

2172 According to the SEEA-EA guidance, one of the EA tasks is to evaluate how various ecosystem types contribute to ES
2173 provisioning (United nations, 2021). However, using broad land cover classes as proxies for varied and complex
2174 ecosystems can lead to significant bias. InVEST models operate with broad land cover classes such as “forest” or
2175 “grassland”. Although this approach is practical, it may obscure significant ecological diversity and misrepresent the true
2176 functioning of particular ecosystem types (Bagstad et al., 2013).

2177 Given high topographic and climatic variability in Armenia, these risks are exacerbated there. With elevations ranging
2178 from 375 to over 4,090 m above sea level, the area of the country includes both lowland semi-deserts and high alpine

2179 regions. Precipitation, soil properties, temperature regimes, and land use can all change quickly in this area, sometimes
 2180 within a few kilometers. In Armenia the category “grassland” encompasses diverse ecosystems, ranging from alpine
 2181 meadows to semideserts, that differ fundamentally in their functioning and in their capacity to provide ES. Average values
 2182 of ES indicators for grasslands do not reflect the diversity of ecosystem functions and services among the various types
 2183 of meadows, steppes, and semideserts. Likewise, not all forests have the same function in regulating hydrology; their
 2184 contributions are influenced by species composition, slope gradient, canopy density, and soil depth (Jenkins and Schaap,
 2185 2018; FAO; IUFRO; USDA, 2021; Creed and van Noordwijk, 2018). Thus, conducting ES accounting at the level of broad
 2186 land cover classes fails to capture ecosystem-specificity, offers little for informed ecosystem-management decisions, and
 2187 in some cases can lead to incorrect decisions. For example, using the average baseflow value for grasslands (59 mm) leads
 2188 to underestimating the contribution of mountain grasslands with baseflow values of 137–155 mm to the total baseflow
 2189 volume.

2190 Biases in understanding the roles of different ecosystem types in delivering ES could have negative consequences for
 2191 environmental policy. Globally, an example of such a bias is the underestimation of grasslands’ roles in water provision
 2192 and soil protection, alongside a primary focus on the ecological value of forests. This often leads to afforestation of natural
 2193 grasslands, resulting in negative impacts on water regulation and soil quality (Parmesan et al., 2022; Holl and Brancalion,
 2194 2020; Veldman et al., 2015).

2195 Even within vegetation zones, which partially account for the diversity of grasslands and woody vegetation, there
 2196 remains a wide spread of ES values across individual polygons, indicating the high heterogeneity of environmental
 2197 conditions and plant communities within them. This raises the question of whether a more detailed ecosystem
 2198 classification and mapping should be used to assess ecosystems’ roles in delivering ES.

2199 The range of values within individual polygons of certain vegetation zones is quite large — in alpine, subalpine,
 2200 meadow-steppe, forest zones, and juniper woodlands.

2201 Developing a detailed ecosystem map based on the ELU approach would help address this issue.

2202 **5.3.F. The feasibility of assessing the entire bundle of water-related ES**

2203 Water regulation is closely linked to the prevention of soil erosion, as well as the cooling effect of evapotranspiration.
 2204 Tested InVEST models use the same data and coefficients (Figure 5.3-1). Therefore, it makes sense to consider water-
 2205 regulating and soil-protection ecosystem services together as an integrated whole.
 2206

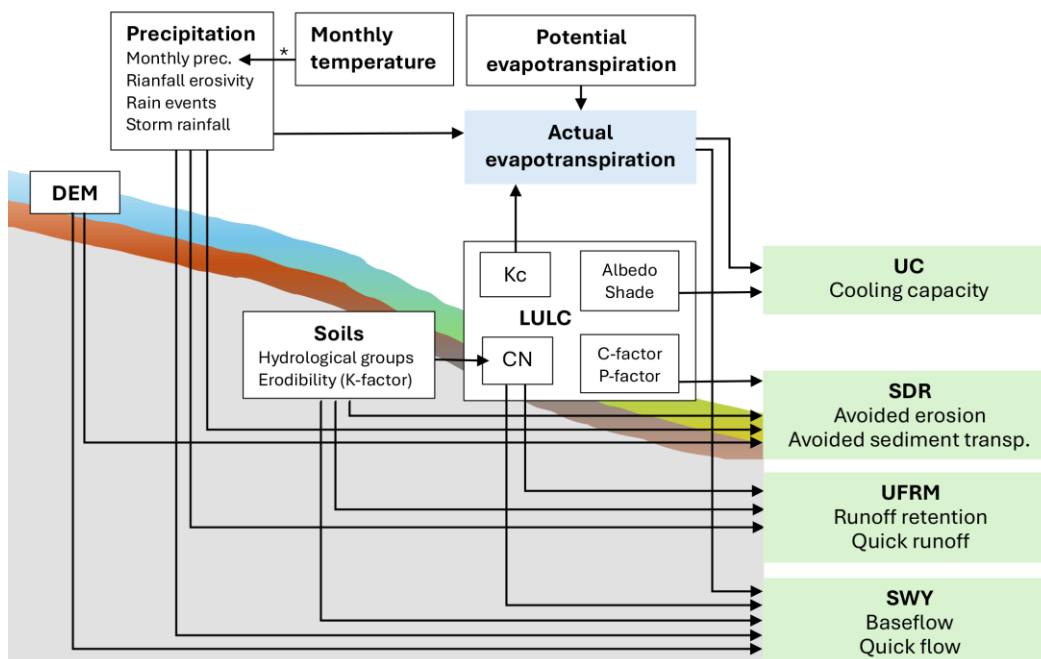

2207
 2208 *Figure 5.3-1 The relationship between the coefficients used in the tested models. *Average monthly temperature values*
 2209 *were used to adjust the average monthly precipitation, taking into account the snow season.*

2210 Our preliminary testing of ES models did not include ES of rainfall pattern regulation, which was recently added to the
 2211 recommended list of ES in the SEEA-EA framework (United nations, 2021). In recent years, this ES has been increasingly
 2212 recognized as fundamentally important, as it completes the hydrological cycle on land. Without accounting for this ES,
 2213 vegetation appears only to evaporate moisture, reducing water availability on land. However, evaporated moisture in

2214 the atmosphere contributes to precipitation recycling, which increases the overall amount of rainfall and enables its
2215 transport further inland (Ellison, 2018; Momblanch et al., 2017; Vogl et al., 2017; Holl and Brancalion, 2020).

2216 SEEA-EA recommendations imply a subcontinental scale of this ES, exceeding the territory of Armenia; however,
2217 several studies have also highlighted its relevance at the regional level, including in arid zones (Vogl et al., 2017; Veldman
2218 et al., 2015). We did not include this ES in our testing, as it is not yet represented in the set of relatively simple models
2219 like InVEST ready to use without specialized research. Moreover, as noted by Wierik et al. 2018, research on this ES has
2220 focused on the global level or on tropical forests, while there is a knowledge gap for other zones, including temperate
2221 forests and grasslands.

2222 According to estimates by Tuinenburg et al. 2022, Armenia lies within a zone with high evaporation recycling ratios,
2223 typical for most land areas, meaning that nearly all evaporated moisture eventually returns as precipitation. The country
2224 also exhibits medium precipitation recycling ratios: in winter, 50–60% of precipitation originates from land evaporation,
2225 and in summer, this figure rises to 70–80%. However, these are only averaged estimates, which may reflect a mosaic of
2226 areas where forests either increase or decrease water availability.

2227 For Armenia, as a mountainous country, another potentially important but still poorly formalized function is the
2228 capture of atmospheric moisture by vegetation in upland areas, which act as “water towers” (Ellison, 2018; Momblanch
2229 et al., 2017).

2230 Models of ESs that return vegetation-evaporated moisture to land should be developed and included alongside other
2231 water-regulating ES in national EA.

6. Starting data-related steps for launching terrestrial ecosystem accounting

2232
2233
2234
2235
2236
2237
2238
2239
2240
2241
2242
2243
2244
2245
2246
2247
2248
2249
2250
2251
2252
2253
2254
2255
2256
2257
2258
2259
2260
2261
2262
2263
2264
2265

The launch of the first phase of ecosystem accounting requires only standard, commonly available hardware and software. The first data-related steps are follows:

- Development of a national land cover dataset verified using ground-based data collected specifically within Armenia. The classes of the national land-cover dataset should be harmonized with the official land-cover area statistics (in particular, including a shrubland class). In addition, to support accurate EE accounting, it is necessary to distinguish two tree-cover classes: closed forest and open woodland. For croplands, it is highly desirable to distinguish between actively used and abandoned arable land, as well as perennial plantations. Refining and adding land-cover classes can be done gradually, in several stages.
- Provide Government-approved digital map of PAs for ecosystem accounting in PAs.
- Develop detailed national ecosystem map to enable more accurate EE accounting for biodiversity conservation purposes, as well as a more precise assessment of the role of ecosystems in providing ES. We recommend developing ecosystem map using GIS-based methods and the conceptual approach Ecological Land Units (ELU).
- To determine the extent of natural ecosystems and to track its changes, use the intersection of the ecosystem map and the land-cover data, excluding anthropogenic land-cover classes (croplands and built-up areas) from the extent of natural ecosystems.
- It is advisable to include ecosystem condition accounting. The indicators “extent of unconverted ecosystems” and “time since abandonment” may serve as valuable proxies for ecosystem quality and can start being recorded immediately after the launch of extent accounting for land-cover and ecosystem classes. At subsequent stages of EA developing, it would be desirable to add an indicator of land degradation and other ecosystem condition indicators.
- At subsequent stages of developing ecosystem accounting, it would be useful to include models of land-cover and ecosystem change driven by climate change, in order to assess the respective contributions of climatic and anthropogenic drivers in ecosystem dynamics.
- Use, alongside the indicators of ES supply-use, recommended by SEEA EA, the indicators proposed by the INCA project (ES potential/capacity; demand in ES and unmet demand, ES overuse, unused ES potential).
- Develop a framework for integrating InVEST and other scoping-stage ES models with advanced hydrological and meteorological models (e.g. SWAT) to account for the high diversity of natural conditions in Armenia, including terrain, geological structure, soil types, and regional climatic differences.
- Use nationally verified data for ES modelling based on in situ measurements from Armenia’s hydrometeorological, geodesy, and cartography services. Develop national and regional database of ES modeling coefficients.
- Make data on forestry and hunting management available for ES accounting.

References

- 2266
- 2267 Allen, R. G., Pruitt, W. O., Raes, D., Smith, M., & Pereira, L. S. (2005). Estimating evaporation from bare soil and the
 2268 crop coefficient for the initial period using common soils information. *Journal of Irrigation and Drainage Engineering*,
 2269 131(1), 14–23. [https://doi.org/10.1061/\(ASCE\)0733-9437\(2005\)131:1\(14\)](https://doi.org/10.1061/(ASCE)0733-9437(2005)131:1(14))
- 2270 Aprikyan, S. V. (1972). Valuable plant raw materials from the flora of Armenia for the food industry. *Biological*
 2271 *Journal of Armenia*, 25(12), 74–79. (In Russian)
- 2272 AQUASTAT: FAO's global information system on water and agriculture. Country profile: Armenia. Retrieved August
 2273 28, 2025, from <https://www.fao.org/aquastat/en/countries-and-basins/country-profiles/country/ARM>
- 2274 Asante, K. O., Artan, G. A., Pervez, S., Bandaragoda, C., & Verdin, J. P. (2008). *Technical manual for the geospatial*
 2275 *stream flow model (GeoSFM)* (U.S. Geological Survey Open-File Report 2007–1441). U.S. Geological Survey.
 2276 <https://pubs.usgs.gov/of/2007/1441/pdf/ofr2008-1441.pdf>
- 2277 Asatryan, V., & Dallakyan, M. (2021). Principles to develop a simplified multimetric index for the assessment of the
 2278 ecological status of Armenian rivers on example of the Arpa River system. *Environmental Monitoring and Assessment*,
 2279 193, 195. <https://doi.org/10.1007/s10661-021-08994-3>
- 2280 Asatryan, V., Keryan, T., Radinger-Peer, V., & Dallakyan, M. (2024). Assessment of cultural ecosystem services
 2281 potential in river catchments in the Caucasus: Evidence from Dilijan National Park, Armenia. *Mountain Research and*
 2282 *Development*, 44, R1–R13. <https://doi.org/10.1659/mrd.2023.00045>
- 2283 Aznar-Sánchez, J. A., Velasco-Muñoz, J. F., Belmonte-Ureña, L. J., & Manzano-Agugliaro, F. (2019). The worldwide
 2284 research trends on water ecosystem services. *Ecological Indicators*, 99, 310–323.
 2285 <https://doi.org/10.1016/j.ecolind.2018.12.045>
- 2286 Baghdasaryan, A. B., Davtyan, G. S., Harutyunyan, A. B., Martirosyan, G. M., Marukhyan, A. G., Mkrtchyan, S. S.,
 2287 Shakhbazyan, M. S., Stepanyan, L. A. (Ed.), & Urusov, V. V. (1961). *Atlas of the Armenian Soviet Socialist Republic*.
 2288 Academy of Sciences of the Armenian SSR; Main Directorate of Geodesy and Cartography.
- 2289 Bagstad, K. J., Semmens, D. J., Waage, S., & Winthrop, R. (2013). A comparative assessment of decision-support
 2290 tools for ecosystem services quantification and valuation. *Ecosystem Services*, 5, 27–39.
 2291 <https://doi.org/10.1016/j.ecoser.2013.07.004>
- 2292 Barseghyan, A. (2007). Armenian flora. In *Armenian national atlas* (Series A).
- 2293 Bernhardt-Römermann, M., Gray, A., Vanbergen, A. J., Bergès, L., Bohner, A., Brooker, R. W., De Bruyn, L., De Cinti,
 2294 B., Dirnböck, T., Grandin, U., Hester, A. J., Kanka, R., Klotz, S., Loucougaray, G., Lundin, L., Matteucci, G., Mészáros, I.,
 2295 Oláh, V., Preda, E., Prévosto, B., Pykälä, J., Schmidt, W., Taylor, M. E., Vadineanu, A., Waldmann, T., & Stadler, J. (2011).
 2296 Functional traits and local environment predict vegetation responses to disturbance: A pan-European multi-site
 2297 experiment. *Journal of Ecology*, 99(3), 777–787. <https://doi.org/10.1111/j.1365-2745.2011.01794.x>
- 2298 Borrelli, P., Robinson, D. A., Fleischer, L. R., Lugato, E., Ballabio, C., Alewell, C., Meusburger, K., Modugno, S., Schutt,
 2299 B., Ferro, V., et al. (2017). An assessment of the global impact of 21st century land use change on soil erosion. *Nature*
 2300 *Communications*, 8, 2013. <https://doi.org/10.1038/s41467-017-02142-7>
- 2301 Creed, I., & van Noordwijk, M. (2018). *Forest and water on a changing planet: Vulnerability, adaptation and*
 2302 *governance opportunities* (IUFRO World Series Vol. 38). International Union of Forest Research Organizations (IUFRO).
 2303 [https://www.iufro.org/publications/world-series-vol-38-forest-and-water-on-a-changing-planet-vulnerability-](https://www.iufro.org/publications/world-series-vol-38-forest-and-water-on-a-changing-planet-vulnerability-adaptation-and-governance-opportunities)
 2304 [adaptation-and-governance-opportunities](https://www.iufro.org/publications/world-series-vol-38-forest-and-water-on-a-changing-planet-vulnerability-adaptation-and-governance-opportunities)
- 2305 Czúcz, B., & Condé, S. (2018). *Ecosystem type fact sheet on grasslands* (ETC/BD Report to the EEA). European Topic
 2306 Centre on Biological Diversity (ETC/BD). Retrieved June 26, 2025, from [https://www.eionet.europa.eu/etcs/etc-](https://www.eionet.europa.eu/etcs/etc-bd/products/etc-bd-reports/etc-bd-report-12-2018-fact-sheets-on-ecosystem-condition/@@download/file/ETCBD_Technical_report_12-2018.zip)
 2307 [bd/products/etc-bd-reports/etc-bd-report-12-2018-fact-sheets-on-ecosystem-](https://www.eionet.europa.eu/etcs/etc-bd/products/etc-bd-reports/etc-bd-report-12-2018-fact-sheets-on-ecosystem-condition/@@download/file/ETCBD_Technical_report_12-2018.zip)
 2308 [condition/@@download/file/ETCBD_Technical_report_12-2018.zip](https://www.eionet.europa.eu/etcs/etc-bd/products/etc-bd-reports/etc-bd-report-12-2018-fact-sheets-on-ecosystem-condition/@@download/file/ETCBD_Technical_report_12-2018.zip)
- 2309 Duku, C., Rathjens, H., Zwart, S. J., & Hein, L. (2015). Towards ecosystem accounting: A comprehensive approach to
 2310 modelling multiple hydrological ecosystem services. *Hydrology and Earth System Sciences*, 19, 4377–4396.
 2311 <https://doi.org/10.5194/hess-19-4377-2015>
- 2312 Ellison, D. (2018). *Forests and water* (Background analytical study 2). United Nations. Retrieved June 26, 2025, from
 2313 https://www.un.org/esa/forests/wp-content/uploads/2018/04/UNFF13_BkgdStudy_ForestsWater.pdf
- 2314 European Commission, & Eurostat. (2021). *Accounting for ecosystems and their services in the European Union*
 2315 *(INCA): Final report from phase II of the INCA project aiming to develop a pilot for an integrated system of ecosystem*
 2316 *accounts for the EU* (2021 ed.). Publications Office of the European Union. <https://doi.org/10.2785/197909>
- 2317 European Commission, Joint Research Centre. (n.d.). *Global soil erosion*. European Soil Data Centre (ESDAC).
 2318 Retrieved August 28, 2025, from <https://esdac.jrc.ec.europa.eu/content/global-soil-erosion>

- 2319 Eurostat. (2024a). *Guidance note on ecosystem extent accounts* (Technical note). Publications Office of the European
 2320 Union. <https://ec.europa.eu/eurostat/documents/1798247/12357920/Guidance-note-ecosystem-extent-accounts.pdf>
 2321 Eurostat. (2024b). *Guidance note on ecosystem services accounts* (Technical note). Publications Office of the
 2322 European Union.
 2323 <https://ec.europa.eu/eurostat/documents/1798247/12357920/Guidance+note+on+ecosystem+services+accounts.pdf>
 2324 Eurostat. (n.d.). *Agri-environmental indicator—Soil erosion*. Retrieved August 28, 2025, from
 2325 [https://ec.europa.eu/eurostat/statistics-explained/index.php?title=Agri-environmental_indicator -
 2326 soil_erosion#Analysis_at_EU_and_country_level](https://ec.europa.eu/eurostat/statistics-explained/index.php?title=Agri-environmental_indicator_-_soil_erosion#Analysis_at_EU_and_country_level)
 2327 FAO, Food and Agriculture Organization of the United Nations, International Union of Forest Research
 2328 Organizations, & United States Department of Agriculture. (2021). *A guide to forest-water management*. FAO.
 2329 <https://doi.org/10.4060/cb6473en>
 2330 FAO, Food and Agriculture Organization of the United Nations. (2011). *State of the world's forests 2011*. FAO.
 2331 <https://www.fao.org/3/i2000e/i2000e.pdf>
 2332 FAO, Food and Agriculture Organization of the United Nations. (n.d.). *ETC during non-growing periods* (Chapter 11).
 2333 Retrieved June 26, 2025, from <https://www.fao.org/4/x0490e/x0490e0h.htm>
 2334 FAO, Food and Agriculture Organization of the United Nations. (n.d.). *ETC: Single crop coefficient (Kc)* (Chapter 6).
 2335 Retrieved June 26, 2025, from <https://www.fao.org/4/X0490E/x0490e0b.htm>
 2336 FAO, Food and Agriculture Organization of the United Nations. (n.d.). *Earth observation: Country indicators*.
 2337 Retrieved June 26, 2025, from <https://www.fao.org/giews/earthobservation/country/index.jsp?code=ARM>
 2338 Fayvush, G. M., & Aleksanyan, A. S. (2016). *Habitats of Armenia*. National Academy of Sciences of the Republic of
 2339 Armenia.
 2340 Fayvush, G., Aleksanyan, A., et al. (2017). Plant profiles. In R. Bussmann (Ed.), *Ethnobotany of the Caucasus* (pp. 99–
 2341 715). Springer. <https://doi.org/10.1007/978-3-319-49412-8>
 2342 Feldman, A. F., Short Gianotti, D. J., Dong, J., Trigo, I. F., Salvucci, G. D., & Entekhabi, D. (2023). Tropical surface
 2343 temperature response to vegetation cover changes and the role of drylands. *Global Change Biology*, 29(1), 110–125.
 2344 <https://doi.org/10.1111/gcb.16455>
 2345 Geoinfo LTD. (2011). *Introduction of payment for ecosystem services schemes in Upper Hrazdan pilot river basin of*
 2346 *Armenia*. Retrieved June 26, 2025, from <https://unece.org/info/publications/pub/22130>
 2347 GIZ EcoServe Project. (2014). *BioTopic: Sensitivity and management models of pastures*. Retrieved June 26, 2025,
 2348 from [https://biodivers-
 2349 southcaucasus.org/uploads/files/GIZ%20\(2014\)%20BioTopic%20Sensitivity%20and%20Management%20Models%20EN
 2350 G.pdf](https://biodivers-southcaucasus.org/uploads/files/GIZ%20(2014)%20BioTopic%20Sensitivity%20and%20Management%20Models%20EN%20G.pdf)
 2351 GIZ EcoServe Project. (2016). *Sensitivity assessment of pasture lands based on simulation models and RS/GIS*
 2352 *techniques in Armenia*. Retrieved June 26, 2025, from [https://biodivers-
 2353 southcaucasus.org/uploads/files/5b46105fd8d01.pdf](https://biodivers-southcaucasus.org/uploads/files/5b46105fd8d01.pdf)
 2354 Godefroid, S., & Koedam, N. (2004). The impact of forest paths upon adjacent vegetation: Effects of the path
 2355 surfacing material on the species composition and soil compaction. *Biological Conservation*, 119(3), 405–419.
 2356 <https://doi.org/10.1016/j.biocon.2004.01.003>
 2357 Grossheim, A. A. (1952). *Plant resources of the Caucasus*. (In Russian)
 2358 Halder, S., Das, S., & Basu, S. (2022). Estimation of seasonal water yield using InVEST model: A case study from West
 2359 Bengal, India. *Arabian Journal of Geosciences*, 15, 1293. <https://doi.org/10.1007/s12517-022-10551-2>
 2360 Hamel, P., Valencia, J., Schmitt, R., Shrestha, M., Piman, T., Sharp, R. P., Francesconi, W., & Guswa, A. J. (2020).
 2361 Modeling seasonal water yield for landscape management: Applications in Peru and Myanmar. *Journal of*
 2362 *Environmental Management*, 270, 110792. <https://doi.org/10.1016/j.jenvman.2020.110792>
 2363 Harutyunyan, H. (1990). *Medieval Armenian phytotherapy herbs*. (In Armenian)
 2364 Hesslerová, P., Pokorný, J., Brom, J., & Rejšková-Procházková, A. (2013). Daily dynamics of radiation surface
 2365 temperature of different land cover types in a temperate cultural landscape: Consequences for the local climate.
 2366 *Ecological Engineering*, 54, 145–154. <https://doi.org/10.1016/j.ecoleng.2013.01.036>
 2367 Hill, R., & Pickering, C. (2009). Differences in resistance of three subtropical vegetation types to experimental
 2368 trampling. *Journal of Environmental Management*, 90(2), 1305–1312. <https://doi.org/10.1016/j.jenvman.2008.07.015>
 2369 Holl, K. D., & Brancalion, P. H. S. (2020). Tree planting is not a simple solution. *Science*, 368, 580–581.
 2370 <https://doi.org/10.1126/science.aba8232>
 2371 Hong, Y., & Adler, R. F. (2008). Estimation of global SCS curve numbers using satellite remote sensing and geospatial
 2372 data. *International Journal of Remote Sensing*, 29, 471–477. <https://doi.org/10.1080/01431160701264292>
 2373 Immerzeel, W. W., Lutz, A. F., Andrade, M., Bahl, A., Biemans, H., Bolch, T., Hyde, S., Brumby, S., Davies, B. J.,
 2374 Elmore, A. C., et al. (2020). Importance and vulnerability of the world's water towers. *Nature*, 577, 364–369.
 2375 <https://doi.org/10.1038/s41586-019-1822-y>

- 2376 Intergovernmental Science–Policy Platform on Biodiversity and Ecosystem Services (IPBES). (2019). *Global*
 2377 *assessment report on biodiversity and ecosystem services* (E. S. Brondizio, J. Settele, S. Díaz, & H. T. Ngo, Eds.). IPBES
 2378 Secretariat. <https://zenodo.org/records/3831674>
- 2379 International Finance Corporation. (2017). *Cheese production and export supply chain: Armenia*. World Bank Group.
 2380 [https://documents1.worldbank.org/curated/en/856631517565616040/pdf/1-2-2018-19-12-0-](https://documents1.worldbank.org/curated/en/856631517565616040/pdf/1-2-2018-19-12-0-ArmeniaCheeseExportENG.pdf)
 2381 [ArmeniaCheeseExportENG.pdf](https://documents1.worldbank.org/curated/en/856631517565616040/pdf/1-2-2018-19-12-0-ArmeniaCheeseExportENG.pdf)
- 2382 Jenkins, M., & Schaap, B. (2018). *Forest ecosystem services* (Background analytical study). United Nations Forum on
 2383 Forests. Retrieved June 26, 2025, from [https://www.un.org/esa/forests/wp-](https://www.un.org/esa/forests/wp-content/uploads/2018/05/UNFF13_BkgdStudy_ForestsEcoServices.pdf)
 2384 [content/uploads/2018/05/UNFF13_BkgdStudy_ForestsEcoServices.pdf](https://www.un.org/esa/forests/wp-content/uploads/2018/05/UNFF13_BkgdStudy_ForestsEcoServices.pdf)
- 2385 Lai, T.-Y., Salminen, J., Jäppinen, J.-P., Koljonen, S., Mononen, L., Nieminen, E., Vihervaara, P., & Oinonen, S. (2018).
 2386 Bridging the gap between ecosystem service indicators and ecosystem accounting in Finland. *Ecological Modelling*, 377,
 2387 51–65. <https://doi.org/10.1016/j.ecolmodel.2018.03.006>
- 2388 Lüke, A., & Hack, J. (2017). Modelling hydrological ecosystem services—A state of the art model comparison.
 2389 *Hydrology and Earth System Sciences Discussions*. <https://doi.org/10.5194/hess-2017-436>
- 2390 Marion, J. L., Leung, Y.-F., Eagleston, H., & Burroughs, K. (2016). A review and synthesis of recreation ecology
 2391 research findings on visitor impacts to wilderness and protected natural areas. *Journal of Forestry*, 114(3), 352–362.
 2392 <https://doi.org/10.5849/jof.15-498>
- 2393 Melkumyan, I. S. (1991). Wild edible plants of the Ararat Valley. In *Flora, vegetation and plant resources of Armenia*
 2394 (Vol. 13, pp. 228–246). (In Russian)
- 2395 Momblanch, A., Paredes-Arquiola, J., & Andreu, J. (2017). Improved modelling of the freshwater provisioning
 2396 ecosystem service in water scarce river basins. *Environmental Modelling & Software*, 94, 87–99.
 2397 <https://doi.org/10.1016/j.envsoft.2017.03.033>
- 2398 Muradyan, A. G. (2019). Honey plants of the flora of Armenia. *Takhtajania*, 5, 80–96. (In Russian)
- 2399 Nedkov, S., Campagne, S., Borisova, B., Krpec, P., Prodanova, H., Kokkoris, I. P., Hristova, D., Le Clec’h, S., Santos-
 2400 Martin, F., Burkhard, B., et al. (2022). Modeling water regulation ecosystem services: A review in the context of
 2401 ecosystem accounting. *Ecosystem Services*, 56, 101458. <https://doi.org/10.1016/j.ecoser.2022.101458>
- 2402 Ochoa, V., & Urbina-Cardona, N. (2017). Tools for spatially modeling ecosystem services: Publication trends,
 2403 conceptual reflections and future challenges. *Ecosystem Services*, 26, 155–169.
 2404 <https://doi.org/10.1016/j.ecoser.2017.06.011>
- 2405 Panagos, P., Borrelli, P., Meusburger, K., Alewell, C., Lugato, E., & Montanarella, L. (2015). Estimating the soil erosion
 2406 cover-management factor at the European scale. *Land Use Policy*, 48, 38–50.
 2407 <https://doi.org/10.1016/j.landusepol.2015.05.021>
- 2408 Parmesan, C., Morecroft, M. D., Trisurat, Y., Adrian, R., Anshari, G. Z., Arneith, A., Gao, Q., Gonzalez, P., Harris, R.,
 2409 Price, J., et al. (2022). Terrestrial and freshwater ecosystems and their services. In H.-O. Pörtner, D. C. Roberts, M.
 2410 Tignor, E. S. Poloczanska, K. Mintenbeck, A. Alegría, M. Craig, S. Langsdorf, S. Löschke, V. Möller, A. Okem, & B. Rama
 2411 (Eds.), *Climate change 2022: Impacts, adaptation and vulnerability* (pp. 197–377). Cambridge University Press.
 2412 <https://doi.org/10.1017/9781009325844.004>
- 2413 Pietsch, M., Uhrig, N., Sayadyan, H., & Kim, D. Y. (2019). Analyzing ecosystem services in Armenia using ArcGIS
 2414 Online: A case study of the Geghard Monastery and the Kotayk Province. *Journal of Digital Landscape Architecture*, 4,
 2415 363–371. <https://doi.org/10.14627/537663039>
- 2416 Píscová, V., Ševčík, M., Hreško, J., & Petrovič, F. (2021). Effects of a short-term trampling experiment on alpine
 2417 vegetation in the Tatras, Slovakia. *Sustainability*, 13(5), 2750. <https://doi.org/10.3390/su13052750>
- 2418 Republic of Armenia. (2014). *Fifth national report to the Convention on Biological Diversity*. Retrieved June 26, 2025,
 2419 from <https://www.cbd.int/doc/world/am/am-nr-05-en.pdf>
- 2420 Rumsey, C. A., Miller, M. P., Susong, D. D., Tillman, F. D., & Anning, D. W. (2015). Regional scale estimates of
 2421 baseflow and factors influencing baseflow in the Upper Colorado River Basin. *Journal of Hydrology: Regional Studies*, 4,
 2422 91–107. <https://doi.org/10.1016/j.ejrh.2015.04.008>
- 2423 Scordo, F., Lavender, T. M., Seitz, C., Perillo, V. L., Rusak, J. A., Piccolo, M. C., & Perillo, G. M. E. (2018). Modeling
 2424 water yield: Assessing the role of site- and region-specific attributes in determining model performance of the InVEST
 2425 seasonal water yield model. *Water*, 10, 1496. <https://doi.org/10.3390/w10111496>
- 2426 Shahnazaryan, N., & Harutyunyan, A. (2017). *Ecosystem services in Armenia: Overview of different activities on*
 2427 *ecosystem services implemented by the Government of Armenia and different organizations in the period of 2011–2017*.
 2428 GIZ EcoServe Project. Retrieved June 26, 2025, from [https://biodivers-](https://biodivers-southcaucasus.org/uploads/files/5b461310dad8a.pdf)
 2429 [southcaucasus.org/uploads/files/5b461310dad8a.pdf](https://biodivers-southcaucasus.org/uploads/files/5b461310dad8a.pdf)
- 2430 Sokolov, P. D. (Ed.). (1984–1993). *Plant resources of the USSR* (Vols. 1–7). Academy of Sciences of the USSR. (In
 2431 Russian)

- 2432 Springgay, E., Casallas Ramirez, S., Janzen, S., & Vannozi Brito, V. (2019). The forest–water nexus: An international
 2433 perspective. *Forests*, 10, 915. <https://doi.org/10.3390/f10100915>
- 2434 Statistical Committee of the Republic of Armenia (Armstat). (2023). *Environment and natural resources in the*
 2435 *Republic of Armenia for 2022: And time series of indexes, 2018–2022* (Edition 25).
 2436 https://Armstat.am/file/article/eco_book_2022_00.pdf
- 2437 Statistical Committee of the Republic of Armenia. (2023). *Summary results of the 2022 population census of the*
 2438 *Republic of Armenia*. <https://Armstat.am/file/doc/99542773.pdf>
- 2439 Statistical Committee of the Republic of Armenia. (n.d.). *Regional statistics*. Retrieved June 26, 2025, from
 2440 <https://Armstat.am/en/?nid=651>
- 2441 Stewart-Koster, B., Bunn, S., Green, P., Ndehedehe, C. E., Anderson, L., Armstrong McKay, D. I., Bai, X., DeClerck, F.,
 2442 Ebi, K., Gordon, C., et al. (2023). Living within the safe and just Earth system boundaries for blue water. *Nature*
 2443 *Sustainability*, 7, 53–63. <https://doi.org/10.1038/s41893-023-01247-w>
- 2444 Takhtajan, A. L. (Ed.). (1954–2009). *Flora of Armenia* (Vols. 1–11). (In Russian)
- 2445 Tamanyan, K. G., Fayvush, G. M., Nanagulyan, S. G., & Danielyan, T. S. (2010). *Red data book of plants of Armenia*.
 2446 Zangak. (In Armenian)
- 2447 The Government of the Republic of Armenia. (2011, April 14). *On approving the procedure for the use of pastures*
 2448 *and hayfields in the Republic of Armenia* (Government decision No. 389-N). Armenian Legal Information System (ARLIS).
 2449 <https://www.arlis.am/DocumentView.aspx?DocID=67394>
- 2450 The Government of the Republic of Armenia. (2023). *UNCCD national report 2022—Armenia*. United Nations
 2451 Convention to Combat Desertification. [https://www.unccd.int/our-work-impact/country-profiles/armenia/country-](https://www.unccd.int/our-work-impact/country-profiles/armenia/country-report/2022)
 2452 [report/2022](https://www.unccd.int/our-work-impact/country-profiles/armenia/country-report/2022)
- 2453 Tovmasyan, G. (2015). *Manual for monitoring of pastures, Armenia*. Deutsche Gesellschaft für Internationale
 2454 Zusammenarbeit (GIZ) GmbH. <https://biodivers-southcaucasus.org/uploads/files/GIZ%20WP%20eng%20.pdf>
- 2455 Tovmasyan, G. (2020). *Manual on improvement of degraded natural grazing lands (pastures and grasslands)*.
 2456 Deutsche Gesellschaft für Internationale Zusammenarbeit (GIZ) GmbH. [https://mineconomy.am/media/11657/GIZ-](https://mineconomy.am/media/11657/GIZ-Degradation_eng.pdf)
 2457 [Degradation_eng.pdf](https://mineconomy.am/media/11657/GIZ-Degradation_eng.pdf)
- 2458 Tsaturyan, T., & Gevorgyan, M. (2007). *Wild edible plants of Armenia*. (In Armenian)
- 2459 Tsaturyan, T., & Gevorgyan, M. (2014). *Wild medicinal plants of Armenia*. (In Armenian)
- 2460 United Nations. (2021). *System of environmental-economic accounting—Ecosystem accounting (SEEA EA)*.
 2461 <https://seea.un.org/ecosystem-accounting>
- 2462 United States Department of Agriculture, Natural Resources Conservation Service. (2009). *Part 630 hydrology*
 2463 *national engineering handbook: Chapter 7 hydrologic soil groups*.
 2464 <https://directives.nrcs.usda.gov/sites/default/files2/1712930597/11905.pdf>
- 2465 United States Department of Agriculture, Natural Resources Conservation Service. (1986). *Urban hydrology for small*
 2466 *watersheds (Technical Release 55)*. <https://www.nrc.gov/docs/ML1421/ML14219A437.pdf>
- 2467 UN-Water. (2018). *The United Nations world water development report 2018: Nature-based solutions for water*.
 2468 UNESCO. <https://www.unwater.org/publications/world-water-development-report-2018>
- 2469 Vallecillo, S., Kakoulaki, G., La Notte, A., Feyen, L., Dottori, F., & Maes, J. (2020). Accounting for changes in flood
 2470 control delivered by ecosystems at the EU level. *Ecosystem Services*, 44, 101142.
 2471 <https://doi.org/10.1016/j.ecoser.2020.101142>
- 2472 Vallecillo, S., La Notte, A., Kakoulaki, G., Roberts, N., Kamberaj, J., Dottori, F., Feyen, L., Rega, C., & Maes, J. (2019).
 2473 *Ecosystem services accounting: Part II—Pilot accounts for crop and timber provision, global climate regulation and flood*
 2474 *control* (EUR 29731 EN, JRC116334). Publications Office of the European Union. <https://doi.org/10.2760/631588>
- 2475 Vallée, D., & Margat, J. (2003). *Review of world water resources by country* (FAO Water Reports No. 23). Food and
 2476 Agriculture Organization of the United Nations. Retrieved August 28, 2025, from
 2477 <https://openknowledge.fao.org/server/api/core/bitstreams/fc9b6271-67a0-4d74-a681-4fc5c882f7aa/content>
- 2478 Veldman, J. W., Overbeck, G. E., Negreiros, D., Mahy, G., Le Stradic, S., Fernandes, G. W., Durigan, G., Buisson, E.,
 2479 Putz, F. E., & Bond, W. J. (2015). Where tree planting and forest expansion are bad for biodiversity and ecosystem
 2480 services. *BioScience*, 65, 1011–1018. <https://doi.org/10.1093/biosci/biv118>
- 2481 Venter, Z. S., Barton, D. N., Chakraborty, T., Simensen, T., & Singh, G. (2022). Global 10 m land use land cover
 2482 datasets: A comparison of Dynamic World, WorldCover and Esri Land Cover. *Remote Sensing*, 14, 4101.
 2483 <https://doi.org/10.3390/rs14164101>
- 2484 Viviroli, D., Dürr, H. H., Messerli, B., Meybeck, M., & Weingartner, R. (2007). Mountains of the world, water towers
 2485 for humanity: Typology, mapping, and global significance. *Water Resources Research*, 43, W07447.
 2486 <https://doi.org/10.1029/2006WR005653>

- 2487 Vogl, A. L., Bryant, B. P., Hunink, J. E., Wolny, S., Apse, C., & Droogers, P. (2017). Valuing investments in sustainable
2488 land management in the Upper Tana River basin, Kenya. *Journal of Environmental Management*, 195, 78–91.
2489 <https://doi.org/10.1016/j.jenvman.2016.10.013>
- 2490 World Meteorological Organization. (2024). *State of global water resources 2023*.
2491 <https://library.wmo.int/idurl/4/69033>
- 2492 World Resources Institute. (2003). *25 countries, housing one-quarter of the population, face extremely high water*
2493 *stress*. Retrieved June 26, 2025, from <https://www.wri.org/insights/highest-water-stressed-countries>
- 2494 Xu, P., Tsendbazar, N.-E., Herold, M., de Bruin, S., Koopmans, M., Birch, T., Carter, S., Fritz, S., Lesiv, M., Mazur, E., et
2495 al. (2024). Comparative validation of recent 10 m-resolution global land cover maps. *Remote Sensing of Environment*,
2496 311, 114316. <https://doi.org/10.1016/j.rse.2024.114316>
- 2497 Yaroshenko, G. D. (1941). Wild vegetable plants of the Armenian SSR. *Bulletin of the Botanical Garden*, 3, 33–37. (In
2498 Russian)
- 2499 Yuejin, L., Kelong, C., Yong, Z., et al. (2022). Short-term impacts of trampling on selected soil and vegetation
2500 properties of alpine grassland in Qilian Mountain National Park, China. *Global Ecology and Conservation*, 38, e02148.
2501 <https://doi.org/10.1016/j.gecco.2022.e02148>
- 2502 Zhao, Y., Liu, Z., & Wu, J. (2020). Grassland ecosystem services: A systematic review of research advances and future
2503 directions. *Landscape Ecology*, 35, 793–814. <https://doi.org/10.1007/s10980-020-00980-3>
- 2504 Zolotnitskaya, S. Ya. (1958–1965). *Medicinal plant resources of the flora of Armenia* (Vols. 1–2). (In Russian)

2505

2506

List of abbreviations

- 2507 Armstat — Statistical Committee of the Republic of Armenia
2508 CBD — Convention on Biological Diversity
2509 ELU — Ecological Land Units
2510 ESA — European Space Agency
2511 ESRI — Environmental Systems Research Institute
2512 GBF — Global Biodiversity Framework
2513 GEA — Global Ecosystems Atlas
2514 GIS — Geographic Information System
2515 GLAD — Global Land Analysis and Discovery laboratory
2516 INCA — Integrated Natural Capital and Ecosystem Services Accounting
2517 InVEST — Integrated Valuation of Ecosystem Services and Trade-offs
2518 IUCN — International Union for Conservation of Nature
2519 LLCC — Landscape–Land Cover Classes
2520 PAs — Protected areas
2521 RLE — IUCN Red List of Ecosystems
2522 SEEA EA — System of Environmental-Economic Accounting—Ecosystem Accounting
2523
2524

Appendix

Appendix 2.1. Brief description of land cover datasets, which were tested and excluded from analysis

	Links	Data provider	Spatial resolution	Temporal availability and resolution	Land cover classes	Future availability	General commentary and issues
Tested land cover datasets							
Dynamic World	<p>Primary link https://dynamicworld.app/</p> <p>Documentation https://dynamicworld.app/about, https://www.nature.com/articles/s41597-022-01307-4</p> <p>Where to get the data Google Earth Engine</p>	Google, World Resources Institute. License – Creative Commons BY-4.0	10 m	2015 –2024 near real-time	<ol style="list-style-type: none"> 1. Water 2. Trees 3. Grass 4. Flooded veg. 5. Crops 6. Shrub & scrub 7. Built 8. Bare 9. Snow and ice 	Project is based on two mature, well-known technologies: Google Earth Engine as processing and publishing engine and ESA Copernicus Sentinel-2 as data source. GEE is one of the key modern geospatial technologies. Sentinel-2 is a long-term program with scheduled activity up to 2033 (ref). These facts point to a secure future of Dynamic World	Initially published in 2022, Google Earth Engine (GEE) based dynamic land cover dataset. Transparent and open-sourced. It is based on Sentinel-2 data and dynamically updated with new data acquisitions (3-5 days revisit time, excluding cloudy periods). Could be challenging for inexperienced users to get data from GEE as files for analysis (designed to be used inside GEE). Very basic classification scheme (e.g. single class “trees” for all forest types). In general, there is no dataset in basic terms. There is a published machine learning algorithm which could be applied to any set of Sentinel-2 imagery, and this algorithm published together with the data at GEE. So users could request land cover data for particular territory based on a given period of Sentinel-2 acquisitions. Python code sample to retrieve data from GEE (using GEE-map package): https://gist.github.com/eduard-kazakov/6bfa6ca1ab4ead0b2d6a3ed3e94dd277
Esri Land Cover	<p>Primary link https://livingatlas.arcgis.com/landcover/</p> <p>Documentation https://www.impactobservatory.com/static/lulc_methodology_accuracy_-_ee742a0a389a85a0d4e7295941504ac2.pdf</p> <p>Where to get the data https://livingatlas.arcgis.com/landcoverexplorer</p>	Esri. License – Creative Commons by Attribution (CC BY 4.0)	10 m	2017 – 2023 1 year	<ol style="list-style-type: none"> 1. Water 2. Trees 3. Flooded veg. 4. Crops 5. Built area 6. Bare ground 7. Snow/Ice 8. Clouds 9. Rangeland 	Land cover is provided by the world leader in geospatial, Esri, and based on the well-known ESA Copernicus Sentinel-2 data. Sentinel-2 is a long-term program with scheduled activity up to 2033 (ref). These facts point to a secure future of Esri Land Cover.	Primary land cover product by Esri, based on machine learning algorithms and Sentinel-2 data. Published every year. Available for direct download as GeoTIF for each year since 2017. Very basic classification scheme (e.g. single class “trees” for all forest types).
ESA WorldCover	<p>Primary link https://esa-worldcover.org/en</p> <p>Documentation</p>	ESA. License – Creative	10 m	2020 –2021 1 year	<ol style="list-style-type: none"> 1. Tree cover 2. Shrubland 3. Grassland 	ESA has not officially confirmed that updates will follow annually, but the project has been extended due to its success and	Flagman land cover project directed by ESA in cooperation with many partners. Based on Sentinel-2 and Sentinel-1 data (mixing optic

	https://worldcover2021.esa.int/documentation Where to get the data https://viewer.esa-worldcover.org/worldcover/	Commons Attribution 4.0 International			<ol style="list-style-type: none"> 4. Cropland 5. Built-up 6. Bare/sparse veg. 7. Snow and Ice 8. Permanent water bodies 9. Herbaceous wetland 10. Mangroves 11. Moss & lichen 	user demand. The current release patterns suggest that future updates might continue, though no fixed schedule has been guaranteed by ESA.	and radar data). Distributed in GeoTIFF format via simple web interface.
GLAD Global Land Cover and Land Use Change	Primary link https://glad.umd.edu/dataset/GLCLUC2020 Documentation https://www.frontiersin.org/journals/remotesensing/articles/10.3389/frsen.2022.856903/full Where to get the data https://storage.googleapis.com/earthenginepartners-hansen/GLCLU2000-2020/v2/download.html	University of Maryland . License – Creative Commons Attribution 4.0 International	30 m	2000 –2020 5 years	<ol style="list-style-type: none"> 1. Terra Firma – True desert 2. Terra Firma – Semi-arid 3. Terra Firma – Dense short vegetation 4. Terra Firma – Tree cover 5. Wetland – Salt pan 6. Wetland – Sparse vegetation 7. Wetland – Dense short vegetation 8. Wetland – Tree cover 9. Open surface water 10. Snow/ice 11. Cropland 12. Built-up 13. Ocean 	Dataset is based on Landsat imagery. Three Landsat satellites are still active, the last one (Landsat 9) was launched in 2021. There are plans to continue the mission with Landsat Next in 2030/2031 (ref), so it seems that mission continuity is secure. The GLAD project of University of Maryland is well-known and highly regarded by the community.	Well-known dataset by University of Maryland based on Landsat imagery archives. Project is focused on estimating global land use changes. Important property of this dataset is how it is detailed, with differentiation of trees by height, water retention time etc.
GLC_FCS30D	Primary link – https://essd.copernicus.org/articles/16/1353/2024/ Documentation – https://essd.copernicus.org/articles/16/1353/2024/ Where to get the data – https://zenodo.org/records/8239305	Liangyun Liu, Xiao Zhang, & Tingting Zhao. License – Creative Commons Attribution 4.0 International	30 m	1985 –2022 1 year	<ol style="list-style-type: none"> 1. Rainfed cropland 2. Herbaceous cover cropland 3. Tree or shrub cover (orchard) cropland 4. Irrigated cropland 5. Open evergreen broadleaved forest 6. Closed evergreen broadleaved forest 7. Open deciduous broadleaved forest 8. Closed deciduous broadleaved forest 9. Open evergreen needle-leaved forest 10. Closed evergreen needle-leaved forest 11. Open deciduous needle-leaved forest 12. Closed deciduous needle-leaved forest 13. Open mixed leaf forest (broadleaved and needle-leaved) 14. Closed mixed leaf forest (broadleaved and needle-leaved) 15. Shrubland 16. Evergreen shrubland 17. Deciduous shrubland 18. Grassland 19. Lichens and mosses 20. Sparse vegetation 21. Sparse shrubland 22. Sparse herbaceous 23. Swamp 24. Marsh 25. Flooded flat 	Dataset is based on Landsat imagery. Three Landsat satellites are still active, the last one (Landsat 9) was launched in 2021. There are plans to continue the mission with Landsat Next in 2030/2031 (ref), so it seems that mission continuity is secure. According to latest publications, authors have intention to continue providing this data in the future. On the one hand they are supported and funded by the Chinese government, on the other hand the project obviously depended on particular scientists, which could be insecure.	This dataset is developed and supported by a group of scientists from different Chinese institutes. It's well-known and cited hundreds of times, authors support it and add data for new years. Land cover is based on Landsat data time series. Project is supported by the National Natural Science Foundation of China. Product has a diverse classification scheme compared to other datasets. Data is distributed in zip archives available at famous scientific open data portal Zenodo, each GeoTIFF inside zip contains data for 20+ years (one band – one year).

					<ul style="list-style-type: none"> 26. Saline 27. Mangrove 28. Salt marsh 29. Tidal flat 30. Impervious surfaces 31. Bare areas 32. Consolidated bare areas 33. Unconsolidated bare areas 34. Water body 35. Permanent ice and snow 	
Datasets excluded from analysis						
MODIS MCD12Q1*	<p>Primary link https://lpdaac.usgs.gov/products/mcd12q1v061/ Documentation https://lpdaac.usgs.gov/documents/1409/MCD12_User_Guide_V61.pdf Where to get the data https://search.earthdata.nasa.gov/search</p>	NASA. License – No restrictions on reuse, redistribution, or modification	500 m	2000 –2023 1 year		<p>MCD12Q1 data is based on the MODIS sensor installed at Terra and Aqua satellites. According to the current plan, Terra MODIS will remain operational and generate the full suite of products until the end of the mission in December 2025, and Aqua MODIS will remain operational and generate the full suite of products until the end of the mission in August 2026 (ref). So we can await product availability up to 2025. This product will probably be replaced by a new generation one, but there is no particular information about it yet</p> <p>We did not consider the MODIS data as a possible landcover for creating an ecosystem map due to its low resolution. However, these data can be used to assess ecosystem services.</p> <p>Well-known global Land Cover dataset, referenced thousands of times. Distributed with 8 different classification schemes. Training data haven't been updated since 2021, so authors ask to be careful about data released after 2021 (ref). Relatively low spatial resolution.</p>
Copernicus Global Land Cover	https://land.copernicus.eu/en/products/global-dynamic-land-cover			2015-2020		Data is available only for 2015-2019, no further updates are planned. Other Copernicus products may be useful for assessing ecosystem services.
ESA CCI/C3S Global Land Cover product	https://www.esa-landcover-cci.org/			1992-2020		Data is available only for 1992-2020. New releases were promised, but there were no actual updates in scheduled dates.
Globeland30	https://www.webmap.cn/commres.do?method=globeDetails&type=brief			2000-2010		Data is available only for 2000 and 2010, no further updates are planned.
GlobCover	https://due.esrin.esa.int/page_globcover.php			2009		Data is available only for 2009, no further updates are planned.
World Terrestrial Ecosystems	https://www.arcgis.com/home/item.html?id=926a206393ec40a590d8caf29ae9a93e			2020		Data is available only for 2020, no further updates are planned.
The Global Land Cover by National Mapping Organizations (GLCNMO)	https://globalmaps.github.io/glcnm.html			2003-2013		Data is available only for 2003-2013, no further updates are planned.

Appendix 2.1.A. Land cover area difference across marzes: Government-reported areas minus areas from tested datasets

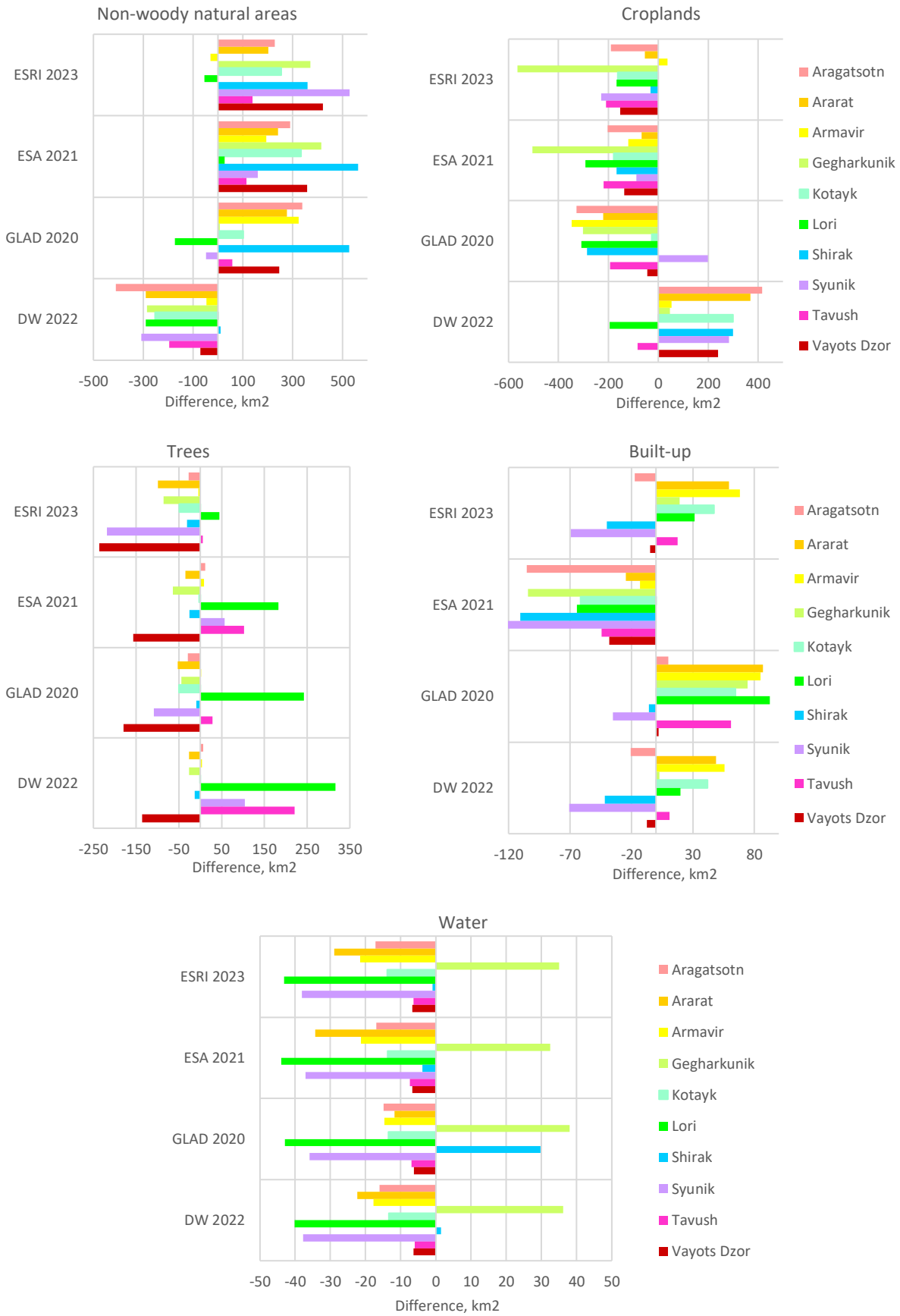

Appendix 2.3.C1. Full vegetation type transition matrix from 2017 to 2023, km²

	Tree cover	Alpine veg.	Subalpine meadows	Meadow-steppe	Steppe	Grasslands in forest zone	Broadleaf woodland	Juniper	Semi-desert	Desert	Marsh	Bare ground	Snow/Ice	Water	Flooded veg.	Crops	Built-up	Total in 2017	Reduction
Tree cover	2909.9	3.2	62.5	11.4	22.7	238.5	18.8	2.0	3.3	0.0	0.4	0.0	0.1	0.6	0.0	3.7	2.7	3279.8	369.9
Alpine vegetation	0.4	1598.1	0.0	0.0	0.0	0.0	0.0	0.0	0.0	0.0	0.0	0.3	7.3	0.2	0.0	2.2	0.1	1608.6	10.4
Subalpine meadows	19.6	0.0	4200.8	0.0	0.0	0.0	0.0	0.0	0.0	0.0	0.0	0.1	0.2	0.4	0.1	60.9	2.8	4284.9	84.0
Meadow-steppe	10.9	0.0	0.0	2547.8	0.0	0.0	0.0	0.0	0.0	0.0	0.0	0.0	0.0	1.8	0.5	269.9	6.1	2837.0	289.2
Steppe	11.3	0.0	0.0	0.0	5020.0	0.0	0.0	0.0	0.0	0.0	0.0	0.2	0.0	1.0	0.0	370.0	21.0	5423.4	403.4
Grassl. in forest zone	143.5	0.0	0.0	0.0	0.0	2616.3	0.0	0.0	0.0	0.0	0.0	0.1	0.0	1.3	0.1	54.8	21.9	2838.0	221.7
Broadleaf woodland	36.2	0.0	0.0	0.0	0.0	0.0	637.2	0.0	0.0	0.0	0.0	0.3	0.0	1.3	0.0	24.9	6.5	706.3	69.1
Juniper	0.9	0.0	0.0	0.0	0.0	0.0	0.0	126.9	0.0	0.0	0.0	0.0	0.0	0.0	0.2	0.2	0.0	128.2	1.2
Semidesert	1.1	0.0	0.0	0.0	0.0	0.0	0.0	0.0	2256.6	0.0	0.0	1.0	0.0	3.6	0.3	141.1	54.2	2457.7	201.1
Desert	0.0	0.0	0.0	0.0	0.0	0.0	0.0	0.0	0.0	6.5	0.0	0.0	0.0	0.0	0.0	0.0	0.3	6.8	0.3
Marsh	0.2	0.0	0.0	0.0	0.0	0.0	0.0	0.0	0.0	0.0	211.5	0.1	0.0	4.0	0.7	17.1	1.8	235.3	23.9
Bare ground	0.1	22.8	10.4	4.0	16.4	8.0	1.0	0.5	11.7	0.1	0.8	29.7	3.7	2.0	0.2	2.1	2.6	115.9	86.3
Snow/Ice	0.0	0.4	0.0	0.0	0.0	0.0	0.0	0.0	0.0	0.0	0.0	0.0	0.3	0.0	0.0	0.0	0.1	1.0	0.6
Water	0.4	0.1	0.4	1.1	0.7	1.2	0.2	0.0	1.3	0.0	3.8	2.3	0.0	101.2	0.5	7.4	1.5	122.1	20.9
Flooded veg.	0.0	0.0	0.0	0.1	0.0	0.5	0.0	0.0	1.7	0.0	0.9	0.0	0.0	4.5	4.8	1.8	0.9	15.4	10.6
Crops	3.0	1.1	12.6	20.3	162.7	21.8	35.5	0.0	178.7	0.1	11.5	0.4	0.3	6.6	1.2	2478.5	97.2	3031.7	553.2
Built-up	3.3	0.0	1.2	2.3	6.7	6.6	2.3	0.2	5.6	0.0	0.8	0.8	0.0	0.5	0.0	14.4	1336.0	1380.7	44.8
Total in 2023	3140.7	1625.7	4288.0	2587.1	5229.3	2892.9	695.0	129.6	2459.0	6.6	229.6	35.4	12.0	128.8	8.5	3448.9	1555.6	28472.8	
Expansion	230.9	27.6	87.2	39.3	209.3	276.6	57.8	2.7	202.4	0.1	18.1	5.7	11.7	27.6	3.7	970.4	219.6		2390.7

Appendix 2.3.C1. Vegetation type transition matrix from 2017 to 2023, % relative to 2017

	Alpine vege-tation	Sub-alpine meadows	Mea-dow-step-pe	Step-pe	Grassl. in forest zone	Juni-per	Broad-leaf wood-land	Semi-desert	De-sert	Marsh	Fo-rests	Water and flood. veg.	Crops	Built-up	Reduc-tion
Alpine veg.	99.81	0.00	0.00	0.00	0.00	0.00	0.00	0.00	0.00	0.00	0.02	0.01	0.14	0.01	0.19
Subalpine meadows	0.00	98.05	0.00	0.00	0.00	0.00	0.00	0.00	0.00	0.00	0.46	0.01	1.42	0.07	1.95
Meadow-steppe	0.00	0.00	89.82	0.00	0.00	0.00	0.00	0.00	0.00	0.00	0.38	0.08	9.50	0.22	10.18
Steppe	0.00	0.00	0.00	92.58	0.00	0.00	0.00	0.00	0.00	0.00	0.21	0.02	6.80	0.39	7.42
Grassl. in forest zone	0.00	0.00	0.00	0.00	92.21	0.00	0.00	0.00	0.00	0.00	5.04	0.05	1.93	0.78	7.79
Juniper	0.00	0.00	0.00	0.00	0.00	99.04	0.00	0.00	0.00	0.00	0.69	0.00	0.12	0.14	0.96
Broadleaf woodland	0.00	0.00	0.00	0.00	0.00	0.00	90.12	0.00	0.00	0.00	5.10	0.35	3.50	0.93	9.88
Semi-desert	0.00	0.00	0.00	0.00	0.00	0.00	0.00	91.78	0.00	0.00	0.04	0.18	5.75	2.25	8.22
Desert	0.00	0.00	0.00	0.00	0.00	0.00	0.00	0.00	96.20	0.00	0.00	0.00	0.15	3.64	3.80
Marsh	0.00	0.00	0.00	0.00	0.00	0.00	0.00	0.00	0.00	89.75	0.08	2.14	7.23	0.79	10.25
Forests	0.10	1.91	0.35	0.69	7.27	0.06	0.57	0.10	0.00	0.01	88.72	0.02	0.11	0.08	11.28
Water and flooded	0.11	0.30	0.86	0.58	1.28	0.02	0.42	3.07	0.00	3.88	0.35	80.68	6.70	1.74	19.32
Crops	0.04	0.42	0.67	5.37	0.72	0.00	1.17	5.91	0.00	0.38	0.10	0.26	81.75	3.21	18.25
Built-up	0.00	0.10	0.17	0.49	0.48	0.01	0.17	0.44	0.00	0.06	0.24	0.04	0.99	96.81	3.19
Expansion	0.29	1.79	1.36	3.69	9.28	1.67	8.20	7.81	0.85	7.82	7.35	19.10	28.12	14.12	

Appendix 2.5.B-1. The proportion of natural landscapes in their total area in Armenia, Sim %, based on Esri 2023 data

	Sub-mountain semi-desert	Mountain-valley semi-desert	Low-mid. mountain forest shelter belt	Low and middle mountain forest	Low mountain, dry steppe	Middle mountain steppe	Middle mountain meadow steppe	High mountain subalpine	High mountain alpine	High-altitude snow-covered
Natural landscapes as a whole										
Aragatsotn	0.00	10.98	0.00	1.08	37.21	12.64	8.07	8.81	7.44	20.11
Ararat	0.00	33.96	3.39	1.20	15.11	13.06	4.59	5.63	3.18	3.03
Armavir	0.00	46.05	0.00	0.00	19.22	0.00	0.00	0.00	0.00	0.00
Gegharkunik	0.00	0.00	5.35	6.15	0.00	19.51	17.65	20.49	19.33	20.71
Kotayk	0.00	0.00	0.00	5.00	11.31	11.45	6.61	6.66	5.83	13.50
Lori	0.00	0.00	8.16	31.31	0.00	9.96	16.89	9.37	6.83	0.00
Shirak	0.00	0.00	0.00	0.00	1.34	9.99	14.89	11.01	7.77	3.85
Syunik	100.00	0.00	33.97	18.46	0.00	10.22	15.26	23.47	34.99	28.05
Tavush	0.00	0.00	49.13	34.49	0.00	0.00	6.76	3.08	0.52	0.00
Vayots Dzor	0.00	9.01	0.00	2.30	15.80	13.17	9.28	11.47	14.12	10.74
Non-woody LLCC										
Aragatsotn	0.00	10.99	0.00	1.57	37.24	12.74	8.21	8.93	7.47	20.12
Ararat	0.00	33.98	4.21	2.24	15.13	13.31	4.55	5.72	3.20	3.04
Armavir	0.00	46.03	0.00	0.00	19.24	0.00	0.00	0.00	0.00	0.00
Gegharkunik	0.00	0.00	6.50	8.47	0.00	19.52	18.79	20.90	19.42	20.68
Kotayk	0.00	0.00	0.00	6.34	11.24	11.46	6.33	6.37	5.85	13.51
Lori	0.00	0.00	8.47	30.41	0.00	9.37	16.79	9.44	6.83	0.00
Shirak	0.00	0.00	0.00	0.00	1.35	10.20	15.67	11.33	7.80	3.85
Syunik	100.00	0.00	34.14	24.03	0.00	10.18	15.31	22.69	34.74	28.06
Tavush	0.00	0.00	46.67	22.42	0.00	0.00	4.79	2.95	0.52	0.00
Vayots Dzor	0.00	9.00	0.00	4.54	15.80	13.22	9.57	11.68	14.17	10.75
Woody LLCC										
Aragatsotn	0.00	0.00	0.00	0.62	25.74	8.31	6.05	4.65	1.99	0.48
Ararat	0.00	25.29	0.00	0.22	4.43	2.34	5.09	2.66	0.00	0.00
Armavir	0.00	60.71	0.00	0.00	6.58	0.00	0.00	0.00	0.00	0.00
Gegharkunik	0.00	0.00	0.66	3.93	0.00	19.10	2.00	6.99	0.55	97.75
Kotayk	0.00	0.00	0.00	3.72	47.68	11.21	10.53	16.47	1.00	0.00
Lori	0.00	0.00	6.88	32.17	0.00	35.36	18.24	6.82	7.70	0.00
Shirak	0.00	0.00	0.00	0.00	0.00	0.66	4.17	0.31	0.00	0.00
Syunik	0.00	0.00	33.26	13.13	0.00	12.10	14.62	49.80	84.48	0.00
Tavush	0.00	0.00	59.20	46.07	0.00	0.00	33.94	7.56	0.00	0.00
Vayots Dzor	0.00	14.01	0.00	0.15	15.57	10.94	5.37	4.74	4.27	1.77

The proportion of natural landscapes in their total area in Armenia, Sim %, based on Esri 2023 data

	Sub-mountain semi-desert	Mountain-valley semi-desert	Low-mid. mountain forest shelter belt	Low-middle mountain forest	Low mountain, dry steppe	Middle mountain steppe	Middle mountain meadow steppe	High mountain subalpine	High mountain alpine	High-altitude snow-covered
Natural landscapes as a whole										
Aragatsotn	0.00	4.31	0.00	1.27	38.30	10.55	8.60	9.27	7.83	14.42
Ararat	0.00	31.22	3.19	1.20	13.62	13.50	4.44	6.34	4.07	6.01
Armavir	0.00	57.41	0.00	0.00	19.66	0.00	0.00	0.00	0.00	0.00
Gegharkunik	0.00	0.00	6.58	6.23	0.00	20.01	17.69	19.86	17.35	10.96
Kotayk	0.00	0.00	0.00	4.81	13.15	11.17	6.34	6.76	6.27	9.92
Lori	0.00	0.00	8.06	32.43		12.27	15.85	8.42	3.20	0.00
Shirak	0.00	0.00	0.00	0.00	0.76	10.08	18.41	13.14	11.47	5.66
Syunik	100.00	0.00	32.76	18.03	0.00	9.00	13.77	21.63	34.35	39.49
Tavush	0.00	0.00	49.39	33.78	0.00	0.00	6.21	2.96	0.85	0.00
Vayots Dzor	0.00	7.07	0.00	2.24	14.50	13.43	8.69	11.63	14.61	13.55
Non-woody LLCC										
Aragatsotn	0.00	2.25	0.00	2.20	36.34	10.49	8.92	9.36	6.58	10.94
Ararat	0.00	27.54	4.19	2.15	11.86	12.98	4.26	6.46	3.73	5.86
Armavir	0.00	35.38	0.00	0.00	15.26	0.00	0.00	0.00	0.00	0.00
Gegharkunik	0.00	0.00	8.94	9.50	0.00	20.40	19.15	20.17	16.99	10.60
Kotayk	0.00	0.00	0.00	6.52	12.62	11.28	6.13	6.55	6.10	8.20
Lori	0.00	0.00	7.54	33.17	0.00	11.83	15.42	8.47	3.19	0.00
Shirak	0.00	0.00	0.00	0.00	0.74	10.39	19.82	13.63	10.89	2.19
Syunik	100.00	0.00	29.84	19.57	0.00	8.18	13.02	19.91	31.77	34.74
Tavush	0.00	0.00	47.61	21.71	0.00	0.00	4.12	2.82	0.86	0.00

Vayots Dzor	0.00	6.67	0.00	4.80	13.56	12.97	8.66	11.52	14.41	12.65
Woody LLCC										
Aragatsotn	0.00	0.19	0.00	0.60	22.55	8.98	4.79	4.64	0.00	0.00
Ararat	0.00	48.34	0.02	0.47	20.77	10.72	6.10	3.00	0.04	0.00
Armavir	0.00	37.04	0.00	0.00	7.88	0.00	0.00	0.00	0.00	0.00
Gegharkunik	0.00	0.00	0.80	3.76	0.00	10.06	1.44	7.07	0.12	0.00
Kotayk	0.00	0.00	0.00	3.54	18.30	5.86	8.42	9.72	0.27	2.60
Lori	0.00	0.00	9.06	31.79	0.00	21.13	20.29	7.06	4.10	0.00
Shirak	0.00	0.00	0.00	0.00	0.18	1.01	3.03	0.41	0.24	0.00
Syunik	100.00	0.00	36.71	16.89	0.00	25.29	20.15	53.83	86.99	97.40
Tavush	0.00	0.00	53.40	42.62	0.00	0.00	28.66	5.93	0.00	0.00
Vayots Dzor	0.00	14.43	0.00	0.32	30.32	16.96	7.12	8.34	8.24	0.00

Appendix 2.5.B-2. Marz importance for conserving all LLCC types in Armenia (the sum of Si indices for each marz)

	Aragatsotn	Ararat	Armavir	Gegharkunik	Kotayk	Lori	Shirak	Syunik	Tavush	Vayots Dzor
Esri 2023										
High mountain alpine N-W	7	4	0	17	6	3	11	32	1	14
High mountain alpine W	0	0	0	0	0	4	0	87	0	8
High mountain subalpine N-W	9	6	0	20	7	8	14	20	3	12
High mountain subalpine W	5	3	0	7	10	7	0	54	6	8
High-altitude snow-covered N-W	11	6	0	11	8	0	2	35	0	13
High-altitude snow-covered W	0	0	0	0	3	0	0	97	0	0
Low mountain, dry steppe N-W	36	12	15	0	13	0	1	0	0	14
Low mountain, dry steppe W	23	21	8	0	18	0	0	0	0	30
Low-middle mount. forest N-W	2	2	0	10	7	33	0	20	22	5
Low-middle mount. forest shelter belt W	0	0	0	1	0	9	0	37	53	0
Low-middle mount. forest shelter... N-W	0	4	0	9	0	8	0	30	48	0
Low-middle mount. forest W	1	0	0	4	4	32	0	17	43	0
Middle mountain meadow steppe N-W	9	4	0	19	6	15	20	13	4	9
Middle mountain meadow steppe W	5	6	0	1	8	20	3	20	29	7
Middle mountain steppe N-W	10	13	0	20	11	12	10	8	0	13
Middle mountain steppe W	9	11	0	10	6	21	1	25	0	17
Mountain-valley semidesert N-W	2	28	35	0	0	0	0	0	0	7
Mountain-valley semidesert W	0	48	37	0	0	0	0	0	0	14
Submountain semidesert N-W	0	0	0	0	0	0	0	100	0	0
Submountain semidesert W	0	0	0	0	0	0	0	100	0	0
Total share	129	168	96	129	106	173	63	694	208	171
ESA 2021										
High mountain alpine N-W	7	4	0	17	6	3	11	32	1	14
High mountain alpine W	0	0	0	0	0	4	0	87	0	8
High mountain subalpine N-W	9	6	0	20	7	8	14	20	3	12
High mountain subalpine W	5	3	0	7	10	7	0	54	6	8
High-altitude snow-covered N-W	11	6	0	11	8	0	2	35	0	13
High-altitude snow-covered W	0	0	0	0	3	0	0	97	0	0
Low mountain, dry steppe N-W	36	12	15	0	13	0	1	0	0	14
Low mountain, dry steppe W	23	21	8	0	18	0	0	0	0	30
Low-middle mount. forest N-W	2	2	0	10	7	33	0	20	22	5
Low-middle mount. forest shelter belt W	0	0	0	1	0	9	0	37	53	0
Low-middle mount. forest shelter... N-W	0	4	0	9	0	8	0	30	48	0
Low-middle mount. forest W	1	0	0	4	4	32	0	17	43	0
Middle mountain meadow steppe N-W	9	4	0	19	6	15	20	13	4	9
Middle mountain meadow steppe W	5	6	0	1	8	20	3	20	29	7
Middle mountain steppe N-W	10	13	0	20	11	12	10	8	0	13
Middle mountain steppe W	9	11	0	10	6	21	1	25	0	17
Mountain-valley semidesert N-W	2	28	35	0	0	0	0	0	0	7
Mountain-valley semidesert W	0	48	37	0	0	0	0	0	0	14
Submountain semidesert N-W	0	0	0	0	0	0	0	100	0	0
Submountain semidesert W	0	0	0	0	0	0	0	100	0	0
Total share	129	168	96	129	106	173	63	694	208	171

Marz importance for conserving LLCC types excluding LLCCs that occupy no more than 5% of the landscape zone's area in Armenia (the sum of Si indices for each marz)

	Aragats-otn	Ararat	Arma-vir	Geghar-kunik	Kotayk	Lori	Shirak	Syunik	Tavush	Vayots Dzor
	Esri 2023									
High mountain alpine N-W	7	4	0	17	6	3	11	32	1	14
High mountain alpine N-W	7	3	0	19	6	7	8	35	1	14
High mountain subalpine N-W	9	6	0	21	6	9	11	23	3	12
High-altitude snow-covered N-W	20	3	0	21	14	0	4	28	0	11
Low and middle mountain forest N-W	2	2	0	8	6	30	0	24	22	5
Low and middle mountain forest W	1	0	0	4	4	32	0	13	46	0
Low mountain, dry steppe N-W	36	15	19	0	11	0	1	0	0	15
Low/mid. mount. forest shelter belt N-W	0	4	0	7	0	8	0	34	47	0
Low/mid. mount. forest shelter belt W	0	0	0	1	0	7	0	33	59	0
Middle mount. meadow steppe W	6	5	0	2	11	18	4	15	34	5
Middle mountain meadow steppe N-W	8	5	0	19	6	17	16	15	5	10
Middle mountain steppe N-W	13	13	0	20	11	9	10	10	0	13
Mountain-valley semidesert N-W	11	33	45	0	0	0	0	0	0	9
Submountain semidesert N-W	0	0	0	0	0	0	0	100	0	0
Total	112	90	64	121	75	139	54	330	217	94
	ESA									
High mountain alpine N-W	7	4	0	17	6	3	11	32	1	14
High mountain subalpine N-W	9	7	0	20	7	9	14	20	3	12
High-altitude snow-covered N-W	11	6	0	11	8	0	2	35	0	13
Low mountain, dry steppe N-W	36	12	15	0	13	0	1	0	0	14
Low-middle mount. forest N-W	2	2	0	10	7	33	0	20	22	5
Low-middle mount. forest shelter belt W	0	0	0	1	0	9	0	37	53	0
Low-middle mount. forest shelter... N-W	0	4	0	9	0	8	0	30	48	0
Low-middle mount. forest W	1	1	0	4	4	32	0	17	43	0
Middle mountain meadow steppe N-W	9	4	0	19	6	15	20	13	4	9
Middle mountain meadow steppe W	5	6	0	1	8	20	3	20	29	7
Middle mountain steppe N-W	11	13	0	20	11	12	10	8	0	13
Mountain-valley semidesert N-W	2	28	35	0	0	0	0	0	0	7
Submountain semidesert N-W	0	0	0	0	0	0	0	100	0	0
Total share	112	93	61	93	69	141	51	331	202	86

Appendix 3.1.A. Coefficients used for InVEST modeling

Table 1. Average number of days with rain by month

Climate zones	Cities	1	2	3	4	5	6	7	8	9	10	11	12
Moderate cool	Севан	1	2	4	7	12	13	9	6	5	2	1	2
	Раздан	2	2	4	5	10	10	8	4	3	2	1	2
	Степанаван	1	1	4	6	11	10	5	3	3	2	1	2
	Ванадзор	2	3	5	8	13	13	8	5	4	3	1	3
	Average	2	2	4	7	12	12	8	5	4	2	1	2
Moderate – humid	Иджеван	1	2	4	6	10	8	4	2	2	2	1	2
	Дилижан	1	2	4	6	11	12	6	4	3	2	1	2
	Алаверди	2	2	4	6	10	8	4	2	2	2	2	2
	Горис	2	2	4	5	9	5	3	1	2	2	2	2
	Average	2	2	4	6	10	8	4	2	2	2	2	2
Arid	Армавир	4	4	5	4	7	7	5	3	4	4	3	4
	Арарат	1	1	1	1	2	1	1	1	0	1	1	1
	Мегри	2	2	4	4	6	3	1	1	1	2	2	2
	Average	2	2	3	3	5	4	2	2	2	2	2	2
Moderate – dry summer	Гюмри	1	1	2	3	6	5	3	2	1	1	1	1
	Гавар	2	3	6	7	13	13	11	8	6	4	2	3
	Варденис	2	1	4	4	9	9	7	4	3	2	2	2
	Сисиан	2	2	4	5	8	7	4	2	2	2	2	3
	Average	2	2	4	5	9	9	6	4	3	2	2	2

Table 2. Precipitation and the number of days with rain in selected cities (<http://armenia.pogoda360.ru/>)

Climate zones	Cities	May			June			Catastrophic rain, mm (50% of monthly precipitation)
		Days with rain	Precipitation, mm	Average rain, mm	Days with rain	Осадку, мм	Average rain, mm	
Moderate cool	Sevan	12	140	12	13	157	12	79
	Hrazdan	10	113	11	10	120	12	60
	Stepanavan	11	141	13	10	130	13	65
	Vanadzor	13	177	14	13	189	15	95
	Average	12	143	12	12	149	13	75
Moderate relatively humid	Idjevan	10	127	13	8	97	12	64
	Dilijan	11	133	12	12	133	11	67
	Alaverdi	10	134	13	8	100	13	67
	Goris	9	103	11	5	63	13	52
	Average	10	124	12	8	98	12	62
Arid	Armavir	7	33	5	7	28	4	17
	Ararat	2	39	20	1	20	20	20
	Meghri	6	81	14	3	44	15	41
	Average	5	51	10	4	31	8	26
Moderate with dry summer	Gyumri	6	78	13	5	71	14	39
	Gavar	13	147	11	13	166	13	74
	Vardenis	9	109	12	9	99	11	55
	Sisian	8	112	14	7	84	12	56
	Average	9	112	12	9	105	12	56
Average		9	110	12	8	99	12	48

Table 3. The coefficients Kc used for crops according to FAO (<https://www.fao.org/4/X0490E/x0490e0b.htm>)

	Ini	Mid	End
GRAINS & LEGUMINOUS	0.35	1.15	0.47
POTATOES	0.5	1.15	0.75
VEGETABLES	0.65	1.1	0.87
MELONS	0.5	1	0.8
FRUITS	0.69	1.05	0.78
GRAPE	0.3	0.775	0.45

Table 4. The share of the area of different agricultural crops in the climate zones, %.

Climate zones	Provinces	GRAINS & LEGUMINOUS	POTATOES	VEGETABLES	MELONS	FRUITS & BERRIES	GRAPE
Arid	Ararat and Armavir (average)	0.12	0.03	0.22	0.07	0.35	0.21
Moderate dry and Moderate cool	Gegharkunik and Shirak (average)	0.79	0.15	0.03	0.00	0.03	0.00
Moderate humid	Tavush	0.33	0.09	0.08	0.01	0.34	0.16

Table 5. Kc values for croplands in the climatic zones

Climate zones	Ini	Mid	End
Arid	0.54	1.00	0.69
Moderate-dry	0.39	1.15	0.54
Moderate cool	0.39	1.15	0.54
Moderate-humid	0.50	1.06	0.64

Table 6. The growing seasons of agricultural crops in the climate zones

Climate zones	1	2	3	4	5	6	7	8	9	10	11	12
Arid	bare	bare	ini	ini	max	max	max	max	end	end	bare	bare
Moderate dry	bare	bare	ini	ini	max	max	max	end	end	bare	bare	bare
Moderate cool	bare	bare	ini	ini	max	max	max	end	end	bare	bare	bare
Moderate humid	bare	bare	ini	ini	max	max	max	end	end	bare	bare	bare

Table 7. Average LAI values by month for natural vegetation in the climate zones based on Copernicus data (<https://land.copernicus.eu/en/map-viewer?product=40b946a9f39f401bae69d25edab45e33>)

Land cover classes	Climate zones	1	2	3	4	5	6	7	8	9	10	11	12
Range-lands	Arid	0.2	0.2	0.3	0.6	1.2	0.6	0.5	0.4	0.3	0.3	0.2	0.2
	Moderate dry	0.3	0.3	0.4	0.9	1.8	3	1.5	0.9	0.7	0.4	0.3	0.3
	Moderate cool	0.2	0.3	0.3	1.0	1.7	2.2	2.2	1.2	0.6	0.4	0.3	0.3
	Moderate humid	0.1	0.2	0.4	0.9	1.8	>3	3	1.5	1.3	0.7	0.3	0.2
Trees*	Moderate humid	0.2	0.3	0.4	1.0	>3	>3	>3	>3	3	1.5	0.3	0.3

Table 8. Kc values used in the InVEST SWY and UC models

LC classes	Climate zones	1	2	3	4	5	6	7	8	9	10	11	12
Rangelands	Arid	0.07	0.07	0.1	0.2	0.4	0.2	0.16	0.13	0.1	0.1	0.07	0.07
	Moderate dry	0.1	0.1	0.13	0.3	0.6	1	0.5	0.3	0.23	0.13	0.1	0.1
	Moderate cool	0.07	0.1	0.1	0.33	0.6	0.7	0.7	0.4	0.2	0.13	0.1	0.1
	Moderate humid	0.07	0.07	0.13	0.3	0.6	1	1	0.5	0.4	0.2	0.1	0.07
Trees*	Moderate humid	0.07	0.1	0.13	0.33	1	1	1	1	1	0.5	0.1	0.1
Croplands	Arid	0.8	0.8	0.54	0.54	1.00	1.00	1.00	1.00	0.69	0.69	0.5	0.8
	Moderate dry	0.8	0.8	0.39	0.39	1.15	1.15	1.15	0.54	0.54	0.5	0.6	0.75
	Moderate cool	0.8	0.8	0.39	0.39	1.15	1.15	1.15	0.54	0.54	0.5	0.6	0.75
	Moderate humid	0.7	0.7	0.50	0.50	1.06	1.06	1.06	0.64	0.64	0.5	0.5	0.7
Bare ground	Arid	0.8	0.8	0.6	0.4	0.5	0.4	0.2	0.2	0.2	0.4	0.5	0.8
	Moderate dry	0.8	0.8	0.7	0.7	0.9	0.8	0.8	0.7	0.5	0.5	0.7	0.7
	Moderate cool	0.8	0.8	1.0	1.0	1.0	1.0	0.6	0.6	0.5	0.5	0.5	0.8
	Moderate humid	0.7	0.7	0.8	0.8	0.9	0.8	0.4	0.2	0.3	0.5	0.5	0.7

* Forests in Armenia predominantly grow in the moderate humid climate zone.

Table 9. Curve numbers used in InVEST models

Land cover classes	Climate zones	A	B	C	D	
Cropland	Arid	60	74	83	87	The average values for row crops and orchards from [TR55], adjusted for their area share in different climatic zones of Armenia.
	Moderate Dry	69	79	86	90	
	Moderate Cool	69	79	86	90	
	Moderate Humid	60	74	83	87	
Rangeland	Arid	55	71	81	89	Values for arid and semiarid grasslands from [TR55]
	Moderate Dry	55	71	81	89	
	Moderate Cool	49	69	79	84	Values for humid grasslands from [TR55]
	Moderate Humid	49	69	79	84	
Trees	All	42	66	79	85	Values for deciduous broadleaf forests from [Hong&Adler]
Built-up	All	73	83	88	91	The average values between open space and impervious from (TR55), assuming a 50% development density
Bare	All	72	82	83	87	Hong&Adler
Snow	All	98	98	98	98	Asante
Water Flooded veg.	All	98	98	98	98	Asante

Appendix 3.1.B-1. Tables for estimation of ES indicators of baseflow maintenance for vegetation types

	Alpine vegetation	Subalpine meadows	Meadow-steppe	Steppe	Grasslands in forest zone	Forests	Juniper	Broadleaf woodland	Semidesert	Desert	Marsh	
	Baseflow in 2023, mm											Bmean in watershed
Aghstev	311.80	107.16		106.60	54.57	12.41		72.86				42.39
Akhuryan	249.61	215.38	159.24	54.03		25.99			12.51		66.69	73.17
Arpa	314.88	74.14	259.08	49.19	79.66	27.57	23.43	77.52	69.74	38.80	58.73	37.29
Debed	324.00	172.10	83.29	59.87	69.24	15.06		34.49			35.23	78.34
Hrazdan	405.64	282.67	180.04	103.40	151.41	28.05	147.00	59.37	29.65		123.06	53.41
Metsamor	228.65	166.82	101.46	31.58	84.10	34.80			104.07		79.89	50.42
Vorotan	78.24	33.98	36.75	26.63	20.85	11.16	17.98	54.60	67.12		25.27	31.02
	Bijnorm - baseflow, normalized to Bmean in watersheds											
Aghstev	7.35	2.53	0.00	2.51	1.29	0.29	0.00	1.72	0.00	0.00	0.00	
Akhuryan	3.41	2.94	2.18	0.74	0.00	0.36	0.00	0.00	0.17	0.00	0.91	
Arpa	8.44	1.99	6.95	1.32	2.14	0.74	0.63	2.08	1.87	1.04	1.57	
Debed	4.14	2.20	1.06	0.76	0.88	0.19	0.00	0.44	0.00	0.00	0.45	
Hrazdan	7.60	5.29	3.37	1.94	2.83	0.53	2.75	1.11	0.56	0.00	2.30	
Metsamor	4.54	3.31	2.01	0.63	1.67	0.69	0.00	0.00	2.06	0.00	1.58	
Vorotan	2.52	1.10	1.18	0.86	0.67	0.36	0.58	1.76	2.16	0.00	0.81	
	Area, km ²											Total
Aghstev	0.31	207.54	0.00	6.37	522.55	1313.81	0.00	482.46	0.00	0.00	0.00	2533.04
Akhuryan	126.23	394.10	406.24	812.13	0.00	13.41	0.00	0.00	17.29	0.00	53.54	1822.94
Arpa	248.60	455.58	109.29	1510.24	421.80	64.31	96.26	13.98	839.21	6.95	66.22	3832.43
Debed	44.31	829.20	632.64	329.75	512.68	882.09	0.00	41.39	0.00	0.00	31.81	3303.87
Hrazdan	502.13	1461.18	615.15	1261.49	521.37	282.63	20.38	12.19	278.26	0.00	101.55	5056.33
Metsamor	201.80	106.57	494.97	513.00	42.47	48.87	0.00	0.00	1198.12	0.00	14.83	2620.63
Vorotan	527.70	837.49	294.45	797.01	898.85	504.59	13.20	153.74	116.02	0.00	13.18	4156.23
	SAij — share of the area of vegetation types across watersheds											Total
Aghstev	0.00	0.08	0.00	0.00	0.21	0.52	0.00	0.19	0.00	0.00	0.00	1.00
Akhuryan	0.07	0.22	0.22	0.45	0.00	0.01	0.00	0.00	0.01	0.00	0.03	1.00
Arpa	0.06	0.12	0.03	0.39	0.11	0.02	0.03	0.00	0.22	0.00	0.02	1.00
Debed	0.01	0.25	0.19	0.10	0.16	0.27	0.00	0.01	0.00	0.00	0.01	1.00
Hrazdan	0.10	0.29	0.12	0.25	0.10	0.06	0.00	0.00	0.06	0.00	0.02	1.00
Metsamor	0.08	0.04	0.19	0.20	0.02	0.02	0.00	0.00	0.46	0.00	0.01	1.00
Vorotan	0.13	0.20	0.07	0.19	0.22	0.12	0.00	0.04	0.03	0.00	0.00	1.00
	SBij - the relative contribution of vegetation types to the baseflow formation in watersheds											Total
Aghstev	0.00	0.21	0.00	0.01	0.27	0.15	0.00	0.33	0.00	0.00	0.00	0.96
Akhuryan	0.24	0.64	0.48	0.33	0.00	0.00	0.00	0.00	0.00	0.00	0.03	1.72
Arpa	0.55	0.24	0.20	0.52	0.24	0.01	0.02	0.01	0.41	0.00	0.03	2.21
Debed	0.06	0.55	0.20	0.08	0.14	0.05	0.00	0.01	0.00	0.00	0.00	1.09
Hrazdan	0.75	1.53	0.41	0.48	0.29	0.03	0.01	0.00	0.03	0.00	0.05	3.59

Metsamor	0.35	0.13	0.38	0.12	0.03	0.01	0.00	0.00	0.94	0.00	0.01	1.98
Vorotan	0.32	0.22	0.08	0.16	0.15	0.04	0.00	0.07	0.06	0.00	0.00	1.11
	SBijnorm - the relative contribution of vegetation types to the baseflow in watersheds, normalized so that the sum of all vegetation types of contributions within each watershed equals 1.											Total
Aghstev	0.00	0.22	0.00	0.01	0.28	0.16	0.00	0.34	0.00	0.00	0.00	1.00
Akhuryan	0.14	0.37	0.28	0.19	0.00	0.00	0.00	0.00	0.00	0.00	0.02	1.00
Arpa	0.25	0.11	0.09	0.24	0.11	0.01	0.01	0.00	0.19	0.00	0.01	1.00
Debed	0.05	0.51	0.19	0.07	0.13	0.05	0.00	0.01	0.00	0.00	0.00	1.00
Hrazdan	0.21	0.43	0.11	0.13	0.08	0.01	0.00	0.00	0.01	0.00	0.01	1.00
Metsamor	0.18	0.07	0.19	0.06	0.01	0.01	0.00	0.00	0.48	0.00	0.00	1.00
Vorotan	0.29	0.20	0.08	0.15	0.13	0.04	0.00	0.06	0.05	0.00	0.00	1.00
	VBij- baseflow volume from vegetation types across watersheds, millions of m ³											Baseflow in watersheds, millions of m ³
Aghstev	0.08	18.31	0.00	0.56	23.47	13.43	0.00	28.94	0.00	0.00	0.00	84.78
Akhuryan	36.37	97.99	74.68	50.65	0.00	0.40	0.00	0.00	0.25	0.00	4.12	264.46
Arpa	112.57	48.57	40.72	106.83	48.32	2.55	3.24	1.56	84.17	0.39	5.59	454.50
Debed	19.82	197.01	72.74	27.25	49.01	18.34	0.00	1.97	0.00	0.00	1.55	387.69
Hrazdan	43.11	87.42	23.44	27.61	16.71	1.68	0.63	0.15	1.75	0.00	2.64	205.13
Metsamor	72.54	27.95	78.95	25.46	5.61	2.67	0.00	0.00	196.02	0.00	1.86	411.06
Vorotan	107.33	73.97	28.13	55.18	48.72	14.63	0.62	21.82	20.24	0.00	0.87	371.51
	BEij -baseflow provided by ecosystems, mm											
Aghstev	307.97	95.67		104.63	48.23	9.51		71.67				
Akhuryan	231.99	208.03	153.22	50.57		15.73			11.21		64.61	
Arpa	302.14	68.31	248.62	44.52	73.34	15.69	20.77	72.27	66.13	37.35	55.74	
Debed	281.04	162.28	76.32	56.07	62.29	9.21		32.87			31.04	
Hrazdan	389.92	272.70	170.09	96.23	142.92	18.40	142.68	51.55	27.63		112.23	
Metsamor	215.53	161.70	96.48	28.86	79.20	26.62			100.63		72.80	
Vorotan	73.36	30.98	33.64	23.95	18.94	8.91	16.55	52.84	65.98		23.67	
	SBEij - the share of provided baseflow in total baseflow (Baseflow provided by ecosystems, mm /Baseflow in 2023, mm)											
Aghstev	98.77	89.27	0.00	98.16	88.39	76.57	0.00	98.37	0.00	0.00	0.00	
Akhuryan	92.94	96.59	96.22	93.60	0.00	60.51	0.00	0.00	89.60	0.00	96.89	
Arpa	95.95	92.14	95.96	90.51	92.07	56.89	88.66	93.23	94.83	96.27	94.91	
Debed	86.74	94.29	91.64	93.67	89.97	61.17	0.00	95.30	0.00	0.00	88.11	
Hrazdan	96.13	96.47	94.47	93.07	94.40	65.59	97.06	86.82	93.18	0.00	91.20	
Metsamor	94.26	96.93	95.09	91.40	94.17	76.50	0.00	0.00	96.70	0.00	91.13	
Vorotan	93.76	91.19	91.53	89.91	90.84	79.90	92.00	96.78	98.31	0.00	93.66	
	VBEij - baseflow volume provided by ecosystems, millions of m ³											Total
Aghstev	0.08	16.34	0.00	0.55	20.75	10.28	0.00	28.46	0.00	0.00	0.00	76.46
Akhuryan	33.80	94.64	71.85	47.41	0.00	0.24	0.00	0.00	0.22	0.00	3.99	252.17
Arpa	108.01	44.75	39.07	96.69	44.49	1.45	2.88	1.45	79.81	0.37	5.31	424.28
Debed	17.19	185.77	66.66	25.53	44.09	11.22	0.00	1.88	0.00	0.00	1.36	353.69
Hrazdan	41.44	84.33	22.14	25.69	15.77	1.10	0.62	0.13	1.63	0.00	2.41	195.26
Metsamor	68.37	27.09	75.07	23.27	5.29	2.04	0.00	0.00	189.54	0.00	1.70	392.38
Vorotan	100.63	67.45	25.75	49.61	44.26	11.69	0.57	21.12	19.90	0.00	0.81	341.79
	Contribution of vegetation types to the water use, millions of m ³											Water use in watersheds

Aghstev	0.02	4.51	0.00	0.14	5.79	3.31	0.00	7.13	0.00	0.00	0.00	20.9
Akhuryan	8.68	23.38	17.82	12.09	0.00	0.10	0.00	0.00	0.06	0.00	0.98	63.1
Arpa	207.03	89.33	74.88	196.47	88.87	4.69	5.97	2.87	154.79	0.71	10.29	835.9
Debed	0.92	9.15	3.38	1.27	2.28	0.85	0.00	0.09	0.00	0.00	0.07	18
Hrazdan	45.94	93.16	24.98	29.42	17.80	1.79	0.68	0.16	1.86	0.00	2.82	218.6
Metsamor	135.72	52.29	147.71	47.64	10.50	5.00	0.00	0.00	366.75	0.00	3.49	769.1
Vorotan	25.86	17.82	6.78	13.29	11.74	3.53	0.15	5.26	4.88	0.00	0.21	89.5
	424.16	289.64	275.54	300.32	136.98	19.26	6.79	15.51	528.34	0.71	17.85	2015.10

Appendix 3.1.B-2. Volume of water use and losses by RA marzes and Yerevan city, 2022, reported by Armstat, mln.m³

		Total use	Drinking	Industrial, domestic and construction	Agriculture, fish breeding and forestry	Losses during transit transportation
Aghstev (a part of Tavush marz)	Tavush	19.2	8.3	1.4	9.5	11.5
Akhuryan (Shirak marz)	Shirak	105.6	7.9	2	95.7	49.5
Arpa (Ararat and Vayots Dzor marzes)	Ararat	898	5.8	5.2	887	45
	Vayots Dzor	17.2	2.2	0.8	14.2	12.9
	Total	17.2	2.2	0.8	14.2	12.9
Debed (Lori marz)	Lori	18.8	9.5	4.2	5.1	36
Hrazdan (Kotayk marz and Yerevan City)	Yerevan city	248.6	39.9	26.1	182.6	157
	Kotayk	189.6	16.8	14.9	157.9	136
	Total	438.2	56.7	41	340.5	293
Metsamor (Armavir and Aragatsotn marzes)	Aragatsotn	282	12.9	6.7	262.4	97.6
	Armavir	494.5	9.7	14.4	470.4	48
	Total	776.5	22.6	21.1	732.8	145.6
Sevan (Gegharkunik marz)	Gegharkunik	59.3	12.1	1	46.2	23.2
Vorotan (Syunik marz)	Syunik	89.5	7.4	63	19.1	32.8
	Total RA	2 422.3	132.5	139.7	2 150.1	649.5

Data reported by Armstat: Environment and Natural Resources in the Republic of Armenia for 2022, <https://Armstat.am/en/?nid=82&id=2603>

Appendix 3.1.C-1. Avoided erosion and avoided sediment export across vegetation types and marzes in 2017

		Alpine vegetation	Subalpine meadows	Meadow-steppe	Steppe	Grassl. in forest zone	Forests	Juniper	Broadleaf woodland	Semidesert	Desert	Marsh	Average
Avoided Erosion T/ha	Aragatsotn	57.04	51.99	32.80	25.42	45.93	59.96	0.00	0.00	18.51	0.00	19.41	30.26
	Ararat	38.60	55.60	49.25	57.52	54.31	85.49	0.00	32.01	14.99	11.69	9.58	42.79
	Armavir	0.00	0.00	0.00	0.00	0.00	2.87	0.00	0.00	6.77	0.00	1.52	6.68
	Gegharkunik	58.09	46.62	35.10	37.91	29.44	57.72	39.84	12.06	0.00	0.00	19.44	42.76
	Kotayk	46.85	59.46	33.91	31.17	47.91	68.66	0.00	38.20	30.53	0.00	34.90	41.96
	Lori	75.34	73.84	43.00	60.46	88.99	114.89	0.00	95.01	0.00	0.00	28.56	78.87
	Shirak	49.00	44.94	22.55	28.93	0.00	51.65	0.00	0.00	19.08	0.00	5.09	31.50
	Syunik	61.72	75.45	57.63	76.70	86.37	111.67	118.57	54.30	41.02	0.00	38.59	78.75
	Tavush	72.06	83.65	0.00	84.30	84.83	120.69	0.00	75.30	0.00	0.00	0.00	101.21
	Vayots Dzor	48.00	60.81	38.31	68.71	67.77	83.68	69.22	32.42	54.83	0.00	30.03	61.98
	Average	56.32	61.02	37.06	48.98	74.30	110.01	69.33	70.63	23.14	11.69	16.21	
Total avoided Erosion Mt	Aragatsotn	1.17	0.56	1.85	1.30	0.19	0.32	0.00	0.00	1.41	0.00	0.01	6.81
	Ararat	0.14	0.35	0.15	4.20	0.95	0.26	0.00	0.03	0.64	0.01	0.04	6.78
	Armavir	0.00	0.00	0.00	0.00	0.00	0.00	0.00	0.00	0.30	0.00	0.00	0.31
	Gegharkunik	2.26	6.03	1.48	3.33	0.68	0.77	0.08	0.01	0.00	0.00	0.18	14.82
	Kotayk	0.53	1.00	0.74	1.42	1.30	1.19	0.00	0.01	0.88	0.00	0.03	7.11
	Lori	0.33	6.28	3.01	2.33	4.93	10.17	0.00	0.48	0.00	0.00	0.09	27.63
	Shirak	0.63	1.92	1.15	2.63	0.00	0.07	0.00	0.00	0.03	0.00	0.02	6.46
	Syunik	3.20	5.99	1.82	6.15	6.91	6.80	0.14	0.76	0.45	0.00	0.03	32.26
	Tavush	0.00	1.72	0.00	0.05	4.55	16.07	0.00	3.73	0.00	0.00	0.00	26.12
	Vayots Dzor	1.01	2.34	0.30	5.25	1.63	0.39	0.67	0.02	2.00	0.00	0.00	13.60
	Total	9.27	26.19	10.51	26.66	21.14	36.05	0.89	5.03	5.71	0.01	0.41	141.88
Avoided sediment	Aragatsotn	5.37	6.32	3.14	2.49	3.98	2.65	0.00	0.00	1.79	0.00	3.68	2.91
	Ararat	3.39	4.96	5.94	6.32	5.64	6.47	0.00	3.44	1.65	0.87	1.01	4.58
	Armavir	0.00	0.00	0.00	0.00	0.00	0.95	0.00	0.00	0.57	0.00	0.42	0.57
	Gegharkunik	5.41	5.27	3.43	3.68	3.31	2.76	4.97	2.14	0.00	0.00	2.25	4.37

	Kotayk	3.93	6.45	3.26	3.05	4.64	2.93	0.00	4.20	3.22	0.00	3.42	3.76
	Lori	4.53	8.02	4.55	6.17	7.81	3.73	0.00	10.61	0.00	0.00	2.81	5.98
	Shirak	4.04	5.05	2.18	2.86	0.00	2.58	0.00	0.00	1.59	0.00	0.94	3.19
	Syunik	5.78	9.17	6.23	8.54	8.53	4.45	12.76	5.89	4.44	0.00	5.43	7.36
	Tavush	4.34	8.38	0.00	6.90	6.53	3.51	0.00	7.42	0.00	0.00	0.00	5.31
	Vayots Dzor	4.47	6.98	3.93	7.52	7.09	6.58	8.27	4.43	6.26	0.00	3.12	6.74
	Average	5.12	6.90	3.77	5.18	6.94	3.74	8.18	7.18	2.45	0.87	1.85	0.00
		Alpine vegetation	Subalpine meadows	Meadow- steppe	Steppe	Grassl. in forest zone	Forests	Juniper	Broadleaf woodland	Semidesert	Desert	Marsh	Total
Total avoided sediment avoided Mt	Aragatsotn	0.11	0.07	0.18	0.13	0.02	0.01	0.00	0.00	0.14	0.00	0.00	0.65
	Ararat	0.01	0.03	0.02	0.46	0.10	0.02	0.00	0.00	0.07	0.00	0.00	0.72
	Armavir	0.00	0.00	0.00	0.00	0.00	0.00	0.00	0.00	0.03	0.00	0.00	0.03
	Gegharkunik	0.21	0.68	0.14	0.32	0.08	0.04	0.01	0.00	0.00	0.00	0.02	1.51
	Kotayk	0.04	0.11	0.07	0.14	0.13	0.05	0.00	0.00	0.09	0.00	0.00	0.64
	Lori	0.02	0.68	0.32	0.24	0.43	0.33	0.00	0.05	0.00	0.00	0.01	2.08
	Shirak	0.05	0.22	0.11	0.26	0.00	0.00	0.00	0.00	0.00	0.00	0.00	0.65
	Syunik	0.30	0.73	0.20	0.68	0.68	0.27	0.02	0.08	0.05	0.00	0.00	3.01
	Tavush	0.00	0.17	0.00	0.00	0.35	0.47	0.00	0.37	0.00	0.00	0.00	1.36
	Vayots Dzor	0.09	0.27	0.03	0.57	0.17	0.03	0.08	0.00	0.23	0.00	0.00	1.48
	Total	0.84	2.96	1.07	2.81	1.95	1.22	0.11	0.51	0.61	0.00	0.05	12.13

Appendix 3.1.C-2. Changes in per-hectare ES provisioning across vegetation types and marzes from 2017 to 2023

	Alpine vegetation	Subalpine meadows	Meadow-steppe	Steppe	Grasslands in forest zone	Forests	Juniper	Broadleaf woodland	Semidesert	Desert	Marsh
Aragatsotn	-0.82	-0.12	0.23	-0.04	0.04	0.07	0.00	0.00	0.02	0.00	-1.25
Ararat	-0.09	-0.01	-0.34	-0.10	0.03	0.83	0.00	0.01	-0.05	0.01	-0.05
Armavir	0.00	0.00	0.00	0.00	0.00	-0.23	0.00	0.00	-0.01	0.00	-0.05
Gegharkunik	-0.14	-0.01	0.14	0.15	0.25	-0.12	-0.02	-0.57	0.00	0.00	0.01
Kotayk	-0.23	-0.09	0.00	0.03	0.16	0.10	0.00	0.06	-0.10	0.00	0.10
Lori	0.07	0.17	0.20	0.40	-0.29	0.07	0.00	-1.98	0.00	0.00	-0.07
Shirak	-0.38	0.18	0.34	0.12	0.00	0.15	0.00	0.00	-0.03	0.00	0.27
Syunik	-0.24	0.02	0.41	0.20	0.79	0.19	0.52	0.08	-0.01	0.00	-0.41
Tavush	-0.06	0.01	0.00	0.63	-0.06	0.12	0.00	-0.28	0.00	0.00	0.00
Vayots Dzor	-0.12	-0.03	0.00	-0.06	0.06	0.77	-0.06	0.13	-0.04	0.00	0.23
Average	-0.27	0.07	0.25	0.11	0.26	0.09	0.04	-0.37	-0.02	0.01	0.03

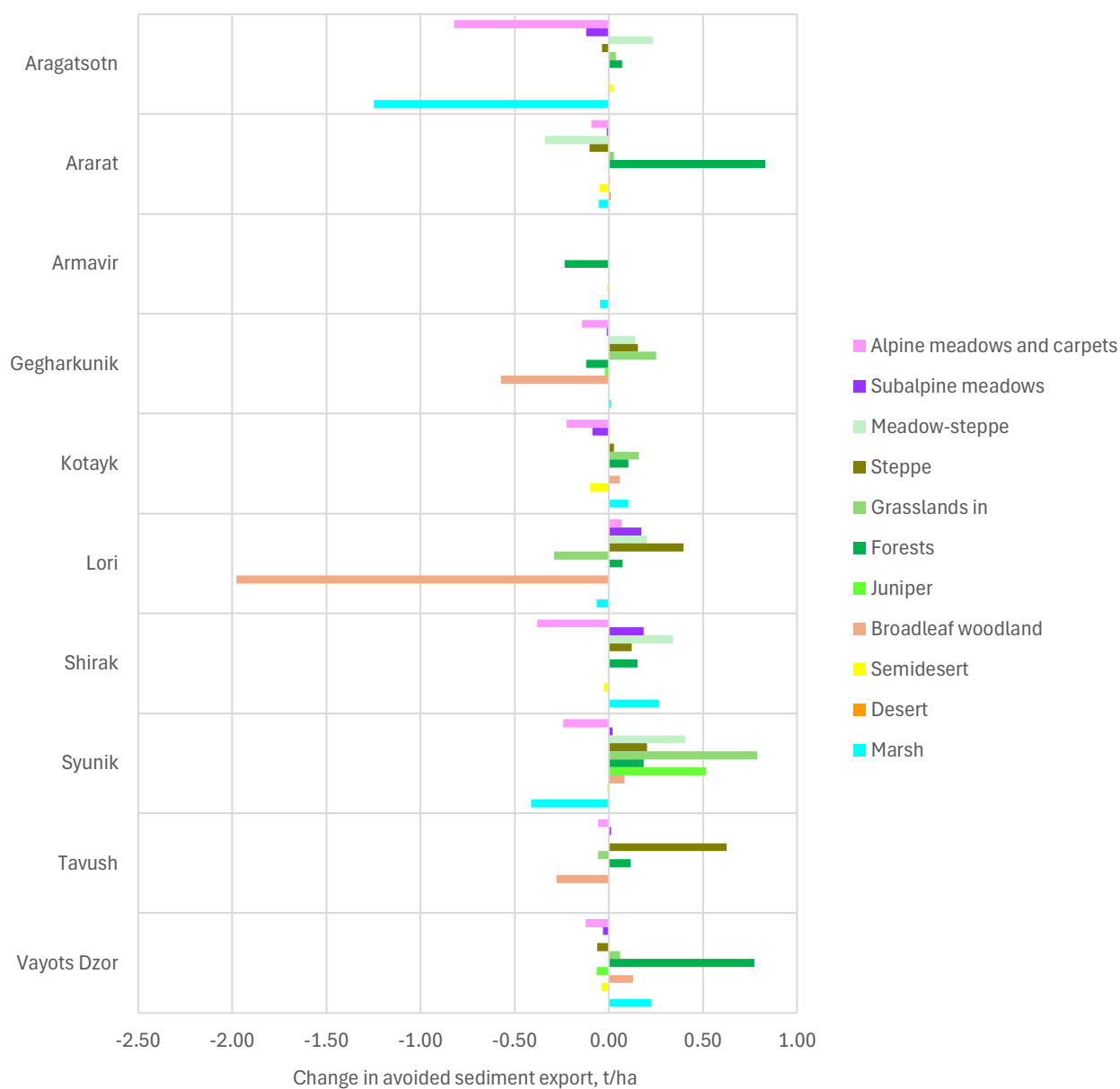

Appendix 3.1.E-1. Cooling capacity (CC) in settlements provided by surrounding ecosystems

Settlements in alphabetical order											
Abkes	0.12	Ardenis	0.16	Bardzrashen	0.19	Dvin	0.21	Gudemnis	0.17	Kaghnut	0.22
Abovyan	0.21	Arđvi	0.19	Bardzrashen	0.1	Dzagikavan	0.15	Gugark	0.19	Kaghsi	0.2
Abovyan	0.19	Aregnadem	0.17	Bardzravan	0.21	Dzithankov	0.2	Gusanagyugh	0.17	Kaghtsrashen	0.21
Abovyan	0.18	Areguni	0.2	Bardzruni	0.21	Dzoraget	0.11	Gushar	0.08	Kajaran	0.18
Achajur	0.2	Areni	0.21	Barekamavan	0.25	Dzoraghbyur	0.18	Gyulagarak	0.21	Kajarants	0.14
Acharkut	0.28	Arevabuyr	0.21	Barepat	0.35	Dzoraglukh	0.2	Gyumri	0.19	Kakavadzor	0.2
Agarak	0.21	Arevadasht	0.09	Bargushat	0.12	Dzoragyugh	0.21	Gyumri	0.17	Kakavasars	0.17
Agarak	0.21	Arevashat	0.22	Basen	0.2	Dzoragyugh	0.19	Haghartsin	0.2	Kakhakn	0.18
Agarak	0.2	Arevashogh	0.2	Bashgyugh	0.19	Dzoragyugh	0.18	Haghpat	0.22	Kalavan	0.31
Agarak	0.17	Arevik	0.24	Batikyan	0.09	Dzorakap	0.2	Haghtanak	0.2	Kamaris	0.2
Agarakadzor	0.21	Arevik	0.2	Bavra	0.19	Dzoramat	0.19	Hagvi	0.19	Kamkhut	0.15
Agarakavan	0.2	Arevis	0.11	Bayandur	0.2	Dzorashen	0.19	Hako	0.14	Kamo	0.18
Aghavnadzor	0.21	Arevshat	0.21	Bazmaghbyur	0.2	Dzorastan	0.23	Halidzor	0.21	Kanachut	0.22
Aghavnadzor	0.19	Arevut	0.15	Bazum	0.21	Dzoravank	0.19	Hankavan	0.18	Kanakeravan	0.19
Aghavnatun	0.23	Argavand	0.27	Bendik	0.12	Dzyunashogh	0.18	Harich	0.17	Kanch	0.2
Aghavnavank	0.14	Argel	0.2	Beniamin	0.18	Erkenants	0.14	Hartagyugh	0.18	Kanashir	0.19
Aghberk	0.17	Argina	0.21	Berd	0.2	Fantan	0.2	Hartashen	0.26	Kapan	0.21
Aghin	0.13	Arin	0.21	Berdashen	0.16	Ferik	0.22	Hartashen	0.15	Kapan	0.21
Aghitu	0.19	Arinj	0.18	Berdavan	0.2	Fioletovo	0.2	Hartavan	0.19	Kaps	0.19
Aghnjadzor	0.23	Arjhovit	0.21	Berdik	0.22	Gagarin	0.17	Hatis	0.19	Kaputan	0.19
Aghtsq	0.2	Arjut	0.19	Berdikunk	0.2	Gai	0.23	Hatsashen	0.16	Kapuyt	0.1
Aghvorik	0.15	Armanis	0.19	Berkaber	0.19	Gandzak	0.2	Hatsavan	0.2	Karaberd	0.19
Ahndidzor	0.22	Armash	0.22	Berkanush	0.23	Gandzak	0.09	Hatsavan	0.18	Karaberd	0.11
Aigehovit	0.22	Armavir	0.25	Berkarat	0.18	Gandzaqar	0.23	Hatsik	0.23	Karadzi	0.13
Ajabaj	0.12	Armavir	0.23	Bergashat	0.23	Gargar	0.21	Hatsik	0.19	Karadzor	0.19
Akhlatyan	0.2	Arpeni	0.13	Bjni	0.19	Garnahovit	0.17	Hatsikavan	0.18	Karaglukh	0.28
Akhpradzor	0.18	Arpi	0.19	Blagodarnoe	0.24	Garnarich	0.14	Hayanist	0.21	Karahunj	0.23
Akhka	0.09	Arpuk	0.19	Bnunis	0.21	Garni	0.2	Haykadzor	0.19	Karakert	0.19
Akhurik	0.17	Arshaluys	0.22	Boloraberd	0.09	Garni	0.19	Haykasars	0.2	Karorum	0.19
Akhuryan	0.19	Artabuynk	0.32	Bovadzor	0.27	Gavar	0.19	Haykashen	0.21	Karashamb	0.2
Aknaghbyur	0.22	Artamet	0.23	Brnakot	0.2	Geghadir	0.21	Haykavan	0.22	Karashen	0.22
Aknalitch	0.21	Artanish	0.18	Burastan	0.23	Geghadir	0.2	Haykavan	0.2	Karbi	0.16
Aknashen	0.22	Artashar	0.23	Burma	0.37	Geghadzor	0.18	Hayravang	0.19	Karchaghbyur	0.2
Akner	0.2	Artashat	0.22	Buzhakan	0.19	Geghakar	0.15	Hayrenyats	0.19	Karchevan	0.21
Akner	0.19	Artashavan	0.17	Byurakan	0.2	Geghakert	0.22	Haytagh	0.22	Kard	0.12
Akori	0.18	Artavan	0.2	Byurakn	0.18	Geghamabak	0.17	Herher	0.19	Karenis	0.19
Akunk	0.2	Artavaz	0.19	Byurashat	0.06	Geghamasar	0.19	Hermon	0.13	Karin	0.21
Akunk	0.18	Arteni	0.21	Byuravan	0.22	Geghamavan	0.19	Hnaberd	0.2	Karinj	0.19
Akunk	0.18	Artik	0.19	Byureghavan	0.17	Geghanist	0.21	Hnaberd	0.18	Karkop	0.14
Alagyaz	0.18	Artimet	0.25	Chakaten	0.22	Geghanist	0.2	Hobardzi	0.21	Karmir Aghek	0.22
Alapars	0.19	Artsni	0.18	Chambarak	0.21	Geghanush	0.19	Hoghmik	0.18	Karmiryugh	0.18
Alashkert	0.23	Artsvanik	0.21	Changli	0.09	Geghard	0.19	Horadis	0.1	Karmaqar	0.17
Alaverdi	0.18	Artsvanist	0.2	Chapkut	0.12	Gegharkunik	0.19	Horbategh	0.28	Karmrashen	0.2
Alvank	0.15	Aruch	0.24	Chapni	0.17	Gegharot	0.19	Horbategh	0.1	Karmrashen	0.18
Alvar	0.17	Arzakan	0.17	Charchakis	0.2	Geghasars	0.18	Horom	0.18	Karmravan	0.19
Amaghu	0.09	Arzni	0.13	Charentsavan	0.19	Geghashen	0.17	Hors	0.36	Karnut	0.18
Amasia	0.25	Ashnak	0.17	Chermakavan	0.11	Geghatap	0.1	Hovit	0.18	Karut	0.12
Amasia	0.16	Ashotavan	0.21	Chinari	0.22	Geghavank	0.12	Hovk	0.25	Kasakh	0.2
Amberd	0.23	Ashotsk	0.15	Chinchin	0.2	Geghavank	0.12	Hovnadzor	0.14	Kashuni	0.11
Amoj	0.23	Ashtarak	0.22	Chiva	0.2	Geghhovit	0.19	Hovtamej	0.22	Katchatchkut	0.14
Amrakits	0.23	Astghadzor	0.2	Chkalov	0.18	Geghi	0.14	Hovtashat	0.21	Katnakhpyur	0.2
Andokavan	0.15	Atan	0.18	Chkalovka	0.17	Getahovit	0.2	Hovtashen	0.21	Kathnarat	0.18
Angeghakot	0.21	Atchhanan	0.22	Chknagh	0.19	Getamej	0.19	Hovtashen	0.17	Katnaghbyur	0.22
Aniavan	0.2	Avan	0.18	Chochkan	0.18	Getap	0.22	Hovtun	0.16	Katnaghbyur	0.18
Anipemza	0.17	Avazan	0.18	Choratan	0.19	Getap	0.18	Hovuni	0.19	Katnajur	0.18
Antaramej	0.23	Avshar	0.22	Dalar	0.21	Getapnya	0.21	Hrazdan	0.18	Katnarat	0.13
Antaramut	0.19	Avshen	0.19	Dalarik	0.19	Getargel	0.2	Hrazdan	0.17	Kavtchut	0.13
Antarashat	0.25	Aygbats	0.18	Darakert	0.21	Getashen	0.25	Hushakert	0.24	Kayan	0.26
Antarashen	0.34	Aygavan	0.22	Daranak	0.18	Getatagh	0.2	Ijevan	0.21	Kayq	0.15
Antaravan	0.1	Aygedzor	0.13	Darbas	0.18	Getavan	0.18	Ijevanatun	0.12	Kechut	0.21
Antarut	0.21	Aygek	0.29	Darbnik	0.23	Getazat	0.21	Irind	0.18	Keti	0.19
Apaga	0.22	Aygeshat	0.24	Darik	0.12	Getik	0.18	Isahakyan	0.2	Khachaghbyur	0.16
Aparan	0.17	Aygeshat	0.2	Darpas	0.19	Getishen	0.18	Ishkhanasar	0.19	Khachardzan	0.18
Apaven	0.18	Aygestan	0.23	Dasht	0.22	Getk	0.19	Itsagar	0.2	Khashashen	0.11
Apagyugh	0.2	Aygevan	0.25	Dashtadem	0.19	Gharibjanyan	0.19	Jaghatsadzor	0.19	Khachik	0.2
Aragats	0.23	Aygezard	0.22	Dashtadem	0.15	Ghazanchi	0.16	Jajur	0.19	Khachik	0.09
Aragats	0.18	Aygut	0.17	Dashtakar	0.21	Ghazaravan	0.18	Jajuravan	0.19	Khachpar	0.21
Aragatsavan	0.21	Ayntap	0.21	Dashtavan	0.21	Ghukavasavan	0.22	Jamatun	0.07	Khandakhach	0.09
Aragatsotn	0.22	Ayrk	0.17	Dastakert	0.13	Ginevet	0.22	Jamshlu	0.18	Khanjyan	0.24
Aragyugh	0.2	Azat	0.18	David Bek	0.21	Gladzor	0.22	Janfida	0.23	Kharkov	0.2
Arajadzor	0.22	Azatamat	0.21	Davtashen	0.18	Gndevaz	0.21	Jermuk	0.32	Khashtarak	0.2
Araks	0.19	Azatan	0.19	Ddmasar	0.15	Gnishik	0.11	Jil	0.19	Khdrants	0.14
Araksashen	0.14	Azatashen	0.21	Ddmashen	0.19	Gogaran	0.19	Jiliza	0.31	Khatsakh	0.21
Aralanj	0.19	Azatavan	0.22	Debet	0.2	Gogavan	0.16	Jraber	0.18	Khndzoresk	0.21
Aralez	0.22	Azatek	0.22	Debetavan	0.22	Goghovit	0.18	Jradzor	0.2	Khndzorut	0.29
Aramus	0.2	Aznvadzor	0.18	Deghdzut	0.21	Goght	0.18	Jrahovit	0.2	Khnkoyan	0.18
Arapi	0.2	Babikavan	0.19	Dian	0.19	Goghtanik	0.2	Jrambar	0.13	Khnik	0.09
Araqs	0.21	Bagaran	0.21	Dilijan	0.3	Gokhth	0.09	Jrapi	0.2	Khor Virap	0.14
Araqsavan	0.23	Baghanis	0.21	Dimitrov	0.21	Gomaran	0.24	Jrarat	0.21	Khordzor	0.12
Ararat	0.21	Baghramyan	0.22	Ditak	0.22	Gomarants	0.12	Jrarat	0.19	Khoronk	0.22
Ararat (village)	0.21	Baghramyan	0.22	Ditavan	0.21	Gomk	0.21	Jrarat	0.16	Khosrov	0.09
Aratashen	0.22	Baghramyan	0.17	Ditsmayri	0.13	Govaran	0.22	Jrabi	0.21	Khot	0.23
Arates	0.1	Bagratashen	0.22	Doghs	0.25	Govayk	0.17	Jrashen	0.24	Khoznavar	0.16
Aravus	0.13	Bagravan	0.18	Dovegh	0.18	Gorgoch	0.41	Jrashen	0.22	Kirants	0.2
Arayi	0.19	Balahovit	0.21	Dprabak	0.19	Goris	0.19	Jrashen	0.19	Kitsk	0.12
Arazap	0.24	Balak	0.19	Dprevank	0.23	Gosh	0.28	Jrvej	0.21	Kobayr	0.44
Arbat	0.21	Bambakashat	0.27	Drakhtik	0.15	Griboyedov	0.26	Jujevan	0.28	Kochaqar	0.1
Archis	0.2	Bandivan	0.16	Dsegh	0.2	Dshayen	0.17	Kabakhlu	0.18	Koghb	0.2

Koghavan	0.2	Melikgyugh	0.19	Odzun	0.2	Shatvan	0.2	Tsakkar	0.2	Voskehat	0.16
Koghes	0.21	Merdzavan	0.21	Ohanavan	0.15	Shenatagh	0.15	Tsamakasar	0.17	Voskepar	0.21
Kopoy Var	0.15	Mets Ayridja	0.12	Okhtar	0.15	Shenavan	0.24	Tsapatagh	0.18	Vosketap	0.22
Kordon	0.09	Mets Ayrum	0.24	Orgov	0.15	Shenavan	0.2	Tsater	0.2	Vosketas	0.18
Kornidzor	0.21	Mets Masrik	0.19	Oshakan	0.22	Shenavan	0.2	Tsav	0.22	Voskevan	0.21
Kosh	0.19	Mets Parni	0.17	Othevan	0.14	Shenik	0.24	Tsghuk	0.19	Voskevas	0.21
Kotayq	0.19	Mets Sariar	0.18	Paghaghbyur	0.11	Shenkani	0.18	Tsghuni	0.09	Vostan	0.22
Koti	0.19	Mets Sepasar	0.19	Paghakan	0.11	Shgharshik	0.16	Tsiatsan	0.21	Yagdan	0.2
Krasar	0.18	Metsadzor	0.12	Paghakn	0.12	Shikahogh	0.21	Tsilkar	0.19	Yegheg	0.18
Krashen	0.17	Metsamor	0.22	Pambak	0.19	Shinuhayr	0.21	Tsoghamarg	0.18	Yeghegis	0.22
Kruglaja Shishka	0.17	Metsamor	0.21	Pambak	0.18	Shirak	0.19	Tsovagyugh	0.2	Yeghegnadzor	0.2
Kuchak	0.19	Metsamoravan	0.21	Parakar	0.21	Shirakamut	0.18	Tsovak	0.21	Yeghegnavan	0.23
Kuris	0.19	Metsavan	0.19	Parpi	0.2	Shirakavan	0.21	Tsovasar	0.19	Yeghegnut	0.23
Kurtan	0.2	Mgart	0.21	Partizak	0.23	Shishkert	0.12	Tsovazard	0.2	Yeghegnut	0.2
Kut	0.17	Mijnatun	0.18	Paruyr Sevak	0.17	Shnogh	0.19	Tsovinar	0.19	Yeghipatrush	0.19
Kutakan	0.16	Mikhayelovka	0.22	Pemzashen	0.19	Shoghakat	0.19	Ttujur	0.2	Yeghnajur	0.1
Lanjaghbyur	0.2	Mirak	0.13	Petrovka	0.21	Shoghakn	0.2	Ttujur	0.18	Yeghnik	0.18
Lanjanist	0.14	Mkhchyan	0.22	Pokr Ayrum	0.16	Shogheravan	0.09	Tufashen	0.2	Yeghvard	0.22
Lanjar	0.15	Monteavan	0.21	Pokr Masrik	0.18	Shramsak	0.09	Tumanyan	0.22	Yeghvard	0.2
Lanjazat	0.18	Mozrov	0.18	Pokr Sepasar	0.17	Shrvenants	0.19	Ughedzor	0.14	Yelpin	0.2
Lanjik	0.2	Mrganush	0.22	Pokr Vedi	0.22	Shurnukh	0.2	Ujan	0.19	Yenokavan	0.21
Lchap	0.2	Mrgashat	0.22	Pokrashen	0.18	Shvanidzor	0.15	Ujanis	0.26	Yeranos	0.18
Lchashen	0.19	Mrgashen	0.22	Pogr Sariar	0.2	Sipan	0.18	Urasar	0.19	Yeraskh	0.18
Lchavan	0.17	Mrgastan	0.25	Por	0.2	Sipanik	0.21	Urtsadzor	0.2	Yeraskhahun	0.23
Lchkadzor	0.21	Mrgavan	0.22	Privolnoye	0.18	Sis	0.21	Urtsalanj	0.17	Yerazgavors	0.2
Lehvaz	0.21	Mrgavet	0.22	Proshyan	0.22	Sisavan	0.22	Urtsashen	0.09	Yerevan	0.18
Lejan	0.21	Mughni	0.21	Pshatavan	0.25	Sisian	0.18	Urut	0.2	Yerizak	0.09
Lenughi	0.26	Musaler	0.23	Ptghavan	0.21	Sizavet	0.18	Ushi	0.15	Yernjatap	0.19
Lermontovo	0.2	Musayelyan	0.18	Ptghni	0.18	Small Glan	0.09	Uyts	0.18	Yervandashat	0.24
Lernadzor	0.19	Mutsk	0.21	Ptghunk	0.22	Smithavan	0.18	Vagharshapat	0.29	Zangakatun	0.2
Lernagog	0.1	Myasnikyan	0.23	Pukhrut	0.12	Solak	0.18	Vaghashen	0.18	Zar	0.19
Lernagyugh	0.11	Nahapetavan	0.17	Pushkino	0.19	Sorik	0.14	Vaghatin	0.19	Zarinja	0.2
Lernahovit	0.2	Nalbandyan	0.23	Pyunik	0.19	Sotk	0.18	Vaghatur	0.22	Zarishat	0.16
Lernajur	0.09	Narek	0.19	Qajashen	0.09	Spandaryan	0.18	Vahagnadzor	0.22	Zaritatap	0.24
Lernakert	0.19	Navur	0.2	Ranchpar	0.21	Spitak	0.16	Vahagni	0.2	Zariver	0.15
Lernakert	0.17	Nerkin Bazmaberd	0.2	Rind	0.21	Srashen	0.2	Vahan	0.2	Zartonk	0.23
Lernamerdz	0.24	Nerkin Getashen	0.2	Rind	0.09	Stepanavan	0.23	Vahramaberd	0.18	Zedea	0.2
Lernanist	0.18	Nerkin Giratagh	0.12	Rya Taza	0.19	Surenavan	0.22	Vahravar	0.13	Zolaqar	0.19
Lernantsq	0.19	Nerkin Khndzoresk	0.21	Sachanlu	0.09	Suser	0.2	Vanadzor	0.21	Zorak	0.21
Lernapar	0.18	Nerkin Khotanan	0.2	Sadunts	0.2	Svarants	0.16	Vanadzor	0.21	Zorakan	0.19
Lernapat	0.18	Nerkin Sasnashen	0.2	Saghagyugh	0.1	Sverdlav	0.2	Vanand	0.16	Zorakert	0.15
Lernarot	0.19	Nerqin Hand	0.24	Saghmosavan	0.16	Syunik	0.22	Vanand	0.13	Zoravan	0.19
Lernavan	0.19	Nerqin Shorja	0.11	Salli	0.21	Sznak	0.15	Vanashen	0.23	Zovaber	0.19
Lernut	0.17	Nigatun	0.08	Salut	0.18	Tairov	0.21	Vanek	0.24	Zovasar	0.18
Lichk	0.21	Nigavan	0.2	Salvard	0.21	Talin	0.17	Vanevan	0.2	Zovashen	0.2
Lichk	0.2	Nizami	0.22	Saragyugh	0.19	Talvorik	0.16	Vank	0.17	Zovk	0.2
Lor	0.2	Nor Amanos	0.19	Sarahart	0.19	Tanahat	0.09	Vardablur	0.22	Zovuni	0.21
Lori Berd	0.22	Nor Akhuryan	0.16	Sarakap	0.16	Tandzatap	0.16	Vardablur	0.19	Zuygakhbyur	0.18
Lorut	0.19	Nor Armavir	0.23	Saralanj	0.2	Tandzaver	0.19	Vardadzor	0.19		
Ltsen	0.2	Nor Artagers	0.24	Saralanj	0.18	Tandzut	0.24	Vardaghybyur	0.16		
Lukashin	0.24	Nor Artamet	0.21	Saralanj	0.17	Taperakan	0.22	Vardahovit	0.17		
Lusadzor	0.2	Nor Artik	0.2	Saralanj	0.16	Taratumb	0.25	Vardanashen	0.24		
Lusadzor	0.11	Nor Astghaberd	0.14	Saramej	0.18	Taronik	0.22	Vardanidzor	0.19		
Lusaghbyur	0.17	Nor Aznaberd	0.5	Saranist	0.09	Tashir	0.17	Vardaqaq	0.17		
Lusaghbyur	0.16	Nor Geghi	0.18	Sarapat	0.18	Tashtun	0.21	Vardashat	0.18		
Lusagyugh	0.22	Nor Gyugh	0.2	Saratak	0.18	Tasik	0.2	Vardashen	0.21		
Lusagyugh	0.18	Nor Hachin	0.21	Saratovka	0.21	Tatev	0.22	Vardavan	0.09		
Lusahovit	0.22	Nor Kesaria	0.22	Saravan	0.16	Tatul	0.18	Vardavank	0.14		
Lusakert	0.19	Nor Khachakap	0.2	Sarchapet	0.18	Tavrus	0.27	Vardenik	0.19		
Lusakn	0.18	Nor Kharberd	0.21	Sardarapat	0.22	Tavshut	0.17	Vardenis	0.19		
Lusakunq	0.18	Nor Kyank	0.22	Sarigyugh	0.2	Tavush	0.2	Vardenis	0.17		
Lusarat	0.22	Nor Kyanq	0.19	Sarnaghybyur	0.19	Tegh	0.22	Vardenut	0.18		
Lusashogh	0.16	Nor Kyurin	0.22	Sarnaghybyur	0.09	Teghenik	0.19	Varser	0.19		
Madina	0.17	Nor Ughi	0.21	Sarnakunk	0.18	Tegher	0.18	Vayk	0.22		
Makenis	0.2	Nor Yedesia	0.22	Sarukhan	0.19	Teghout	0.2	Vayk	0.19		
Malev	0.12	Nor Yerznka	0.25	Sasunik	0.21	Teghut	0.27	Vazashen	0.23		
Malishka	0.21	Norabak	0.18	Sayat Nova	0.2	Tigranashen	0.13	Vedi	0.28		
Maralik	0.2	Norabats	0.22	Semyonovka	0.15	Tkhkut	0.13	Vedi	0.22		
Margahovit	0.21	Noraduz	0.2	Sers	0.21	Tlik	0.17	Verin Akhtala	0.13		
Margara	0.22	Norakert	0.21	Sevaberd	0.19	Tolors	0.21	Verin Artashat	0.22		
Marmarashen	0.21	Norakert	0.18	Sevakar	0.18	Torfavan	0.2	Verin Bazmaberd	0.19		
Marmarik	0.17	Noramarg	0.22	Sevan	0.18	Torosgyugh	0.18	Verin Dvin	0.21		
Marmashen	0.2	Noramut	0.13	Sevazhayr	0.1	Torunik	0.15	Verin Getashen	0.2		
Martiros	0.2	Norapat	0.22	Sevkar	0.2	Tretuq	0.16	Verin Giratagh	0.12		
Marts	0.2	Norashen	0.22	Shaghap	0.16	Tsaghkahovit	0.2	Verin Khotanan	0.22		
Martuni	0.28	Norashen	0.2	Shaghat	0.21	Tsaghkalanj	0.32	Verin Ptghni	0.21		
Martuni	0.19	Norashen	0.19	Shagik	0.13	Tsaghkasar	0.2	Verin Sasnashen	0.19		
Masis	0.21	Norashenik	0.22	Shahumian	0.22	Tsaghkashen	0.19	Verin Sasunik	0.15		
Masis	0.2	Noravan	0.26	Shahumyan	0.22	Tsaghkashen	0.19	Verin Shorzha	0.12		
Mastara	0.19	Noravan	0.19	Shahumyan	0.18	Tsaghkavan	0.2	Verishen	0.21		
Mayakovski	0.2	Novoseltsovo	0.18	Shahumyan	0.12	Tsaghkunk	0.21	Vermashen	0.22		
Mayisyan	0.21	Noyakert	0.23	Shamb	0.21	Tsaghkunk	0.17	Vocheti	0.12		
Mayisyan	0.18	Noyemberyan	0.21	Shamiram	0.24	Tsaghkut	0.14	Voghjaberd	0.21		
Medovka	0.22	Nrnadzor	0.06	Shamlugh	0.29	Tsakhkaber	0.18	Voghji	0.18		
Meghradzor	0.19	Nshavan	0.22	Shamut	0.19	Tsakhkadzor	0.35	Vorotan	0.19		
Meghrashat	0.2	Nshkharq	0.17	Shaqi	0.19	Tsakhkasar	0.09	Vorotan	0.17		
Meghri	0.14	Nurnus	0.18	Shatin	0.27	Tsakhkashat	0.18	Voskehask	0.19		
Megvahovit	0.13	Nzhddeh	0.09	Shatjrek	0.2	Tsakhkots	0.08	Voskehat	0.22		

Settlements in descending order of CC											
Nor Aznaberd	0.5	Amoj	0.23	Ptghunk	0.22	Gomk	0.21	Vahan	0.2	Akunk	0.2
Kobayr	0.44	Bergashat	0.23	Avshar	0.22	Malishka	0.21	Sayat Nova	0.2	Martiros	0.2
Gorgoch	0.41	Amrakits	0.23	Bagratashen	0.22	Bnunis	0.21	Aramus	0.2	Tsakkar	0.2
Burma	0.37	Myasnikyan	0.23	Karmir Aghek	0.22	Sis	0.21	Hatsavan	0.2	Lanjik	0.2
Hors	0.36	Partizak	0.23	Mkhchyan	0.22	David Bek	0.21	Urut	0.2	Tasik	0.2
Barepat	0.35	Nor Armavir	0.23	Aragatsotn	0.22	Nor Artamet	0.21	Chiva	0.2	Yagdan	0.2
Tsakhkadzor	0.35	Hatsik	0.23	Goravan	0.22	Margahovit	0.21	Shurnukh	0.2	Akhlatyan	0.2
Antarashen	0.34	Antaramej	0.23	Aratashen	0.22	Nerkin Khndzoresk	0.21	Masis	0.2	Apnaghyugh	0.2
Jermuk	0.32	Aygestan	0.23	Oshakan	0.22	Araqs	0.21	Garni	0.2	Por	0.2
Artabuynk	0.32	Dzorastan	0.23	Surenavan	0.22	Norakert	0.21	Zangakaton	0.2	Kaghsi	0.2
Tsaghkalanj	0.32	Artamet	0.23	Tsav	0.22	Tashtun	0.21	Ltsen	0.2	Lichk	0.2
Jiliza	0.31	Amberd	0.23	Gladzor	0.22	Verin Ptghni	0.21	Berd	0.2	Saralanj	0.2
Kalavan	0.31	Armavir	0.23	Chakaten	0.22	Lichk	0.21	Srashen	0.2	Nerkin Getashen	0.2
Dilijan	0.3	Yeghegnavan	0.23	Baghramyan	0.22	Metsamor	0.21	Achajur	0.2	Mayakovski	0.2
Shamlugh	0.29	Aghavnatun	0.23	Syunik	0.22	Shikahogh	0.21	Agarak	0.2	Lchap	0.2
Aygek	0.29	Aghnjadzor	0.23	Azatek	0.22	Mgart	0.21	Lernahovit	0.2	Kirants	0.2
Vagharshapat	0.29	Noyakert	0.23	Tegh	0.22	Ditavan	0.21	Yeghegnadzor	0.2	Arapi	0.2
Khndzorut	0.29	Karahunj	0.23	Mrgashen	0.22	Monteavan	0.21	Norashen	0.2	Astghadzor	0.2
Acharkut	0.28	Berkanush	0.23	Haytagh	0.22	Ijevan	0.21	Lor	0.2	Nigavan	0.2
Martuni	0.28	Stepanavan	0.23	Ghukasavan	0.22	Karchevan	0.21	Aygeshat	0.2	Shatjrek	0.2
Karaglukh	0.28	Burastan	0.23	Norabats	0.22	Jrvej	0.21	Dzorakap	0.2	Noraduz	0.2
Gosh	0.28	Darbniik	0.23	Byuravan	0.22	Voskevaz	0.21	Kakavadzor	0.2	Kathnakhyur	0.2
Vedi	0.28	Artashat	0.23	Baghramyan	0.22	Agarak	0.21	Yeghegnut	0.2	Shenavan	0.2
Jujevan	0.28	Dasht	0.22	Taperakan	0.22	Areni	0.21	Torfavan	0.2	Haykasar	0.2
Horbategh	0.28	Berdik	0.22	Verin Artashat	0.22	Abovyan	0.21	Yeghvard	0.2	Chinchin	0.2
Tavrus	0.27	Lusahovit	0.22	Arajadzor	0.22	Lejan	0.21	Agarakavan	0.2	Shenavan	0.2
Teghut	0.27	Debetavan	0.22	Voskehat	0.22	Arjhovit	0.21	Tsaghkavan	0.2	Shatvan	0.2
Bambakashat	0.27	Apaga	0.22	Yeghvard	0.22	Salvard	0.21	Suser	0.2	Nor Khachakap	0.2
Bovadzor	0.27	Verin Khotanan	0.22	Aralez	0.22	Bagaran	0.21	Brnakot	0.2	Zede	0.2
Shatin	0.27	Aknashen	0.22	Ditak	0.22	Gargar	0.21	Arevik	0.2	Karchaghbyur	0.2
Argavand	0.27	Geghakert	0.22	Jrashen	0.22	Mughni	0.21	Kurtan	0.2	Haghartsin	0.2
Hartashen	0.26	Armash	0.22	Aigehovit	0.22	Vanadzor	0.21	Akner	0.2	Nerkin Bazmaberd	0.2
Kayan	0.26	Lusagyugh	0.22	Norapat	0.22	Kechut	0.21	Nerkin Khotanan	0.2	Meghrashat	0.2
Noravan	0.26	Lusarat	0.22	Ginevet	0.22	Dvin	0.21	Zovashen	0.2	Yerazgavors	0.2
Griboyedov	0.26	Tumanyan	0.22	Kaghnut	0.22	Bazum	0.21	Khashtarak	0.2	Maralik	0.2
Lenughi	0.26	Nshavan	0.22	Arbat	0.22	Arin	0.21	Marmashen	0.2	Verin Getashen	0.2
Ujanis	0.26	Mrgashat	0.22	Shinuhayr	0.21	Petrovka	0.21	Vaghatur	0.2	Tsovazard	0.2
Barekamavan	0.25	Ashtarak	0.22	Zorak	0.21	Nor Hachin	0.21	Kharkov	0.2	Hnaberd	0.2
Taratumb	0.25	Kanachut	0.22	Darakert	0.21	Gndevaz	0.21	Archis	0.2	Fantan	0.2
Hovk	0.25	Taronik	0.22	Baghanis	0.21	Ptghavan	0.21	Goghtanik	0.2	Jradzor	0.2
Antarashat	0.25	Aknaghbyur	0.22	Dimitrov	0.21	Agarak	0.21	Getatagh	0.2	Ttujur	0.2
Aygevan	0.25	Vedi	0.22	Yenokavan	0.21	Zovuni	0.21	Sarigyugh	0.2	Kamaris	0.2
Amasia	0.25	Khoronk	0.22	Masis	0.21	Noyemberyan	0.21	Karmrashen	0.2	Dzoraglukh	0.2
Mrgastan	0.25	Noramarg	0.22	Nor Ughi	0.21	Arevshat	0.21	Kanch	0.2	Nor Gyugh	0.2
Artimet	0.25	Chinari	0.22	Dalar	0.21	Gyulagarak	0.21	Aragyugh	0.2	Fioletovo	0.2
Doghs	0.25	Hovtamej	0.22	Agarakadzor	0.21	Chambarak	0.21	Parpi	0.2	Sadunts	0.2
Armavir	0.25	Aygavan	0.22	Bardzruni	0.21	Angeghakot	0.21	Bazmaghbyur	0.2	Getahovit	0.2
Getashen	0.25	Haghpat	0.22	Sipanik	0.21	Vanadzor	0.21	Vaghashen	0.2	Tsovagyugh	0.2
Pshatavan	0.25	Yeghegis	0.22	Merdzavan	0.21	Saratovka	0.21	Tsaghkasar	0.2	Argel	0.2
Nor Yerznka	0.25	Metsamor	0.22	Ararat (village)	0.21	Metsamoravan	0.21	Jrapi	0.2	Koghbavan	0.2
Nerqin Hand	0.24	Arshaluys	0.22	Khachpar	0.21	Mayisyan	0.21	Artsvanist	0.2	Tsaghkahovit	0.2
Lukashin	0.24	Ferik	0.22	Koghesh	0.21	Dzoragyugh	0.21	Berdkunk	0.2	Pogr Sariar	0.2
Aygeshat	0.24	Milkhayelovka	0.22	Deghdzut	0.21	Dashtakar	0.21	Kasakh	0.2	Odzun	0.2
Khanjyan	0.24	Katnaghbyur	0.22	Azatashen	0.21	Halidzor	0.21	Itsaqar	0.2	Areguni	0.2
Gomaran	0.24	Norashen	0.22	Tsaghkunk	0.21	Shaghat	0.21	Nor Artik	0.2	Charchakis	0.2
Jrashen	0.24	Ahmidzor	0.22	Ayntap	0.21	Shamb	0.21	Zovk	0.2	Zoravan	0.19
Zaritap	0.24	Arevashat	0.22	Getapnya	0.21	Haykashen	0.21	Arevashogh	0.2	Pambak	0.19
Arazap	0.24	Getap	0.22	Kornidzor	0.21	Geghadir	0.21	Aghtsq	0.2	Tsovasar	0.19
Vanek	0.24	Nor Kesaria	0.22	Geghanist	0.21	Voskevan	0.21	Haghtanak	0.2	Kotayg	0.19
Yervandashat	0.24	Proshyan	0.22	Marmarashen	0.21	Ashtotavan	0.21	Sverdlov	0.2	Dalarik	0.19
Shenavan	0.24	Vernashen	0.22	Tsiatsan	0.21	Aragatsavan	0.21	Khachik	0.2	Bardzrashen	0.19
Vardanashen	0.24	Shahumian	0.22	Dashtavan	0.21	Arteni	0.21	Zarinja	0.2	Pyunik	0.19
Nor Artagers	0.24	Haykavan	0.22	Ranchpar	0.21	Verishen	0.21	Isahakyan	0.2	Pemzashen	0.19
Lernamerdz	0.24	Sisavan	0.22	Aknalitch	0.21	Tolors	0.21	Urtsadzor	0.2	Getk	0.19
Shenik	0.24	Nor Kyank	0.22	Lehvaz	0.21	Voghjaberd	0.21	Haykavan	0.2	Arpunk	0.19
Mets Ayrum	0.24	Mrgavan	0.22	Hovtashat	0.21	Hayanist	0.21	Dsegh	0.2	Vardanidzor	0.19
Arevik	0.24	Lori Berd	0.22	Sasunik	0.21	Tsovak	0.21	Berdavan	0.2	Aralanj	0.19
Aruch	0.24	Nor Kyurin	0.22	Azatamat	0.21	Rind	0.21	Marts	0.2	Shnogh	0.19
Hushakert	0.24	Nor Yedesia	0.22	Hovtashen	0.21	Lchkadzor	0.21	Karashamb	0.2	Akhuryan	0.19
Shamiram	0.24	Vayk	0.22	Salli	0.21	Hobardzi	0.21	Makenis	0.2	Chknagh	0.19
Tandzut	0.24	Vardablur	0.22	Arevabuyr	0.21	Khndzoresk	0.21	Tavush	0.2	Gyumri	0.19
Blagodarnoe	0.24	Sardarapat	0.22	Tairov	0.21	Balahovit	0.21	Basen	0.2	Geghhovit	0.19
Vazashen	0.23	Margara	0.22	Verin Dvin	0.21	Kapan	0.21	Vanevan	0.2	Lchashen	0.19
Zartonk	0.23	Vostan	0.22	Getazat	0.21	Antarut	0.21	Aniavan	0.2	Sarukhan	0.19
Khot	0.23	Pokr Vedi	0.22	Aghavnadzor	0.21	Shirakavan	0.21	Yelpin	0.2	Gavar	0.19
Araqsavan	0.23	Shahumyan	0.22	Sers	0.21	Parakar	0.21	Lermontovo	0.2	Antaramut	0.19
Vanashen	0.23	Aygezard	0.22	Karin	0.21	Ararat	0.21	Tufashen	0.2	Balak	0.19
Gandzaqar	0.23	Mrgavet	0.22	Jrarbi	0.21	Mutsk	0.21	Shoghakn	0.2	Saragyugh	0.19
Aragats	0.23	Atchanan	0.22	Khnatsakh	0.21	Kapan	0.21	Lanjaghbyur	0.2	Dzoragyugh	0.19
Yeraskhahun	0.23	Karashen	0.22	Vardashen	0.21	Jrahovit	0.2	Geghanist	0.2	Noravan	0.19
Yeghegnut	0.23	Vahagnadzor	0.22	Argina	0.21	Getargel	0.2	Gandzak	0.2	Ujan	0.19
Dprevan	0.23	Tatev	0.22	Bardzravan	0.21	Artavan	0.2	Geghadir	0.2	Hagvi	0.19
Nalbandyan	0.23	Nizami	0.22	Goris	0.21	Vahagni	0.2	Debet	0.2	Shaqi	0.19
Gai	0.23	Norashenik	0.22	Jrarat	0.21	Sevkar	0.2	Dzithankov	0.2	Azatan	0.19
Janfida	0.23	Mrganush	0.22	Nor Kharberd	0.21	Teghout	0.2	Bayandur	0.2	Pushkino	0.19
Musalier	0.23	Medovka	0.22	Kaghtsrashen	0.21	Lusadzor	0.2	Nerkin Sasnashen	0.2	Vardenis	0.19
Alashkert	0.23	Vosketap	0.22	Voskepar	0.21	Koghb	0.2	Tsater	0.2	Zolaqar	0.19
Artashar	0.23	Azatavan	0.22	Artsvanik	0.21	Byurakan	0.2	Navur	0.2	Alapars	0.19

Voskehask	0.19	Bjni	0.19	Ptghni	0.18	Geghashen	0.17	Zorakert	0.15	Arevis	0.11
Karakorum	0.19	Kuris	0.19	Aygabats	0.18	Vardenis	0.17	Arevut	0.15	Saghagyugh	0.1
Aghavnadzor	0.19	Hovuni	0.19	Yeghnik	0.18	Chapni	0.17	Kamkhut	0.15	Horadis	0.1
Garni	0.19	Karenis	0.19	Getap	0.18	Arzakan	0.17	Andokavan	0.15	Arates	0.1
Babikavan	0.19	Arayi	0.19	Dzoraghbyur	0.18	Gorayk	0.17	Shvanidzor	0.15	Sevazhayr	0.1
Armanis	0.19	Hatsik	0.19	Sarchapet	0.18	Tavshut	0.17	Ohanavan	0.15	Geghatap	0.1
Kuchak	0.19	Yeghipatrush	0.19	Getishen	0.18	Vorotan	0.17	Ddmasar	0.15	Kochaghar	0.1
Kaps	0.19	Sarnaghbyur	0.19	Daranak	0.18	Baghramyanyan	0.17	Kopoy Var	0.15	Horbategh	0.1
Artavaz	0.19	Ardvi	0.19	Apaven	0.18	Talin	0.17	Dashtadem	0.15	Lernagog	0.1
Lernavan	0.19	Karakert	0.19	Hankavan	0.18	Gtashen	0.17	Hartashen	0.15	Antaravan	0.1
Zar	0.19	Tandzaver	0.19	Berkarat	0.18	Byureghavan	0.17	Shenatagh	0.15	Kapuyt	0.1
Gharibjanyan	0.19	Lusakert	0.19	Zuygakhbyur	0.18	Madina	0.17	Aghavnnavank	0.14	Yeghnajur	0.1
Koti	0.19	Vardablur	0.19	Sizavet	0.18	Aygut	0.17	Khor Virap	0.14	Bardzrashen	0.1
Kaputan	0.19	Gugark	0.19	Torosgyugh	0.18	Kruglaja Shishka	0.17	Kajarants	0.14	Sachanlu	0.09
Araks	0.19	Tsaghkashen	0.19	Avan	0.18	Mets Parni	0.17	Garnarich	0.14	Sarnaghbyur	0.09
Jil	0.19	Arjut	0.19	Geghadzor	0.18	Gusanagyugh	0.17	Erkenants	0.14	Rind	0.09
Kosh	0.19	Urasar	0.19	Mijnatun	0.18	Gyumri	0.17	Meghri	0.14	Amaghu	0.09
Lernarot	0.19	Shrvenants	0.19	Yeranos	0.18	Vardagar	0.17	Vardavank	0.14	Lernajur	0.09
Geghanush	0.19	Mets Sepasar	0.19	Khachardzan	0.18	Aregnadem	0.17	Hako	0.14	Urtsashen	0.09
Varser	0.19	Keti	0.19	Hoghmik	0.18	Tashir	0.17	Hovnadzor	0.14	Akhta	0.09
Vorotan	0.19	Verin Sasnashen	0.19	Arinj	0.18	Garnahovit	0.17	Araksashen	0.14	Khachik	0.09
Gogaran	0.19	Vayk	0.19	Sarnakunk	0.18	Hovtashen	0.17	Khdrants	0.14	Arevasdash	0.09
Mets Masrik	0.19	Mastara	0.19	Sarapat	0.18	Geghamabak	0.17	Sorik	0.14	Tsakhkasar	0.09
Yernjatap	0.19	Ishkhanasar	0.19	Ghazaravan	0.18	Krashen	0.17	Othevan	0.14	Shogheravan	0.09
Aghitu	0.19	Tsghuk	0.19	Vosketas	0.18	Lernakert	0.17	Tsaghkut	0.14	Gandzak	0.09
Bavra	0.19	Dzoramat	0.19	Yeraskh	0.18	Lernut	0.17	Ughedzor	0.14	Khandakhach	0.09
Haykadzor	0.19	Geghamasar	0.19	Pambak	0.18	Tlik	0.17	Karkop	0.14	Bolorberd	0.09
Vardadzor	0.19	Arpi	0.19	Lanjazat	0.18	Nshkharq	0.17	Nor Astghaberd	0.14	Shramsak	0.09
Sevaberd	0.19	Jaghatsadzor	0.19	Voghji	0.18	Tsamakasar	0.17	Lanjanist	0.14	Yerizak	0.09
Kanakeravan	0.19	Avshen	0.19	Saralanj	0.18	Gudemnis	0.17	Geghi	0.14	Kordon	0.09
Shamut	0.19	Jajuravan	0.19	Artanish	0.18	Artashavan	0.17	Katchatchkut	0.14	Changli	0.09
Vardenik	0.19	Berkaber	0.19	Vahramaberd	0.18	Ashnak	0.17	Tigranashen	0.13	Nzhdeh	0.09
Karadzor	0.19	Avazan	0.18	Khnkoyan	0.18	Alvar	0.17	Megvahovit	0.13	Saranist	0.09
Lernantsq	0.19	Karmrashen	0.18	Yegheg	0.18	Agarak	0.17	Noramut	0.13	Qajashen	0.09
Ddmashen	0.19	Uyts	0.18	Shirakamat	0.18	Marmarik	0.17	Mirak	0.13	Khosrov	0.09
Karinj	0.19	Atan	0.18	Byurakn	0.18	Aghberk	0.17	Aghin	0.13	Tanahat	0.09
Charentsavan	0.19	Aznvadzor	0.18	Vardashat	0.18	Vardahovit	0.17	Arpeni	0.13	Vardavan	0.09
Kaniashir	0.19	Lernapar	0.18	Tatul	0.18	Ayrk	0.17	Ditsmayri	0.13	Tsghuni	0.09
Norashen	0.19	Goghovit	0.18	Hatsikavan	0.18	Karmraaqar	0.17	Kavtchut	0.13	Gokht	0.09
Buzhakan	0.19	Pokr Masrik	0.18	Bagravan	0.18	Aparan	0.17	Jrambar	0.13	Small Glan	0.09
Melikgyugh	0.19	Zovasar	0.18	Karmirgyugh	0.18	Bandivan	0.16	Vanand	0.13	Batikyan	0.09
Geghamavan	0.19	Nor Geghi	0.18	Smithavan	0.18	Ardenis	0.16	Hermon	0.13	Khnutik	0.09
Hartavan	0.19	Kamo	0.18	Saramej	0.18	Svarants	0.16	Aygedzor	0.13	Nigatun	0.08
Lernakert	0.19	Chkalov	0.18	Kabakhlu	0.18	Voskehat	0.16	Aravus	0.13	Tsakhkots	0.08
Dzorashen	0.19	Abovyan	0.18	Tsoghamarg	0.18	Shaghap	0.16	Dastakert	0.13	Gushar	0.08
Karaberd	0.19	Kakhakn	0.18	Getik	0.18	Lusaghbyur	0.16	Tkhkut	0.13	Jamatun	0.07
Meghradzor	0.19	Mets Sariar	0.18	Davtashen	0.18	Vanand	0.16	Vahravar	0.13	Nrnadzor	0.06
Jrarat	0.19	Dovegh	0.18	Horom	0.18	Khachaghbyur	0.16	Katnarat	0.13	Byurashat	0.06
Metsavan	0.19	Nurnus	0.18	Lernapat	0.18	Jrarat	0.16	Arzni	0.13		
Shirak	0.19	Solak	0.18	Hrazdan	0.18	Berdashen	0.16	Verin Akhtala	0.13		
Hayrenyats	0.19	Darbas	0.18	Goght	0.18	Karbi	0.16	Karadzi	0.13		
Dashtadem	0.19	Tegher	0.18	Azat	0.18	Gogavan	0.16	Shagik	0.13		
Getamej	0.19	Tsakhkashat	0.18	Shahumyan	0.18	Shgharshik	0.16	Gomarants	0.12		
Gegharot	0.19	Alaverdi	0.18	Pokrashen	0.18	Sarakap	0.16	Malev	0.12		
Dian	0.19	Sisian	0.18	Artsni	0.18	Spitak	0.16	Khordzor	0.12		
Jajur	0.19	Hartagyugh	0.18	Vardenut	0.18	Tandzatap	0.16	Ijevanatun	0.12		
Lorut	0.19	Yerevan	0.18	Sevan	0.18	Ghazanchi	0.16	Shahumyan	0.12		
Gegharkunik	0.19	Dzoragyugh	0.18	Lernanist	0.18	Hovtun	0.16	Paghakn	0.12		
Karmravan	0.19	Akori	0.18	Beniamin	0.18	Amasia	0.16	Abkes	0.12		
Narek	0.19	Salut	0.18	Dzyunashogh	0.18	Tretuq	0.16	Bargushat	0.12		
Martuni	0.19	Katnaghbyur	0.18	Karnut	0.18	Saravan	0.16	Darik	0.12		
Vaghatin	0.19	Sevakar	0.18	Shenkani	0.18	Vardaghbyur	0.16	Mets Ayridja	0.12		
Zorakan	0.19	Lusagyugh	0.18	Ttujur	0.18	Saralanj	0.16	Nerkin Giratagh	0.12		
Herher	0.19	Spandaryan	0.18	Irind	0.18	Hatsashen	0.16	Geghavank	0.12		
Nor Amanos	0.19	Hatsavan	0.18	Chochkan	0.18	Pokr Ayrum	0.16	Geghavank	0.12		
Shoghakat	0.19	Lusakunq	0.18	Geghasar	0.18	Khoznavar	0.16	Pukhrut	0.12		
Abovyan	0.19	Alagyaz	0.18	Akunk	0.18	Saghmosavan	0.16	Vocheti	0.12		
Verin Bazmaberd	0.19	Hnaberd	0.18	Norabak	0.18	Zarishat	0.16	Verin Giratagh	0.12		
Artik	0.19	Jamshlu	0.18	Akunk	0.18	Nor Akhuryan	0.16	Bendik	0.12		
Lernadzor	0.19	Krasar	0.18	Musayelyan	0.18	Lusashogh	0.16	Chapkut	0.12		
Akner	0.19	Getavan	0.18	Hovit	0.18	Talvorik	0.16	Shishkert	0.12		
Choratan	0.19	Novoseltsovo	0.18	Anipemza	0.17	Kutakan	0.16	Karut	0.12		
Zovaber	0.19	Sipan	0.18	Lusaghbyur	0.17	Zariver	0.15	Metsadzor	0.12		
Geghard	0.19	Mozrov	0.18	Saralanj	0.17	Ashotsk	0.15	Kard	0.12		
Darpas	0.19	Tsakhkaber	0.18	Tsaghkunk	0.17	Sznak	0.15	Ajabaj	0.12		
Dprabak	0.19	Aragats	0.18	Kut	0.17	Kayq	0.15	Verin Shorzha	0.12		
Tsaghkashen	0.19	Tsapatagh	0.18	Harich	0.17	Orgov	0.15	Kitsk	0.12		
Tsilkar	0.19	Kathnarat	0.18	Hrazdan	0.17	Drakhtik	0.15	Paghakan	0.11		
Hatis	0.19	Saratak	0.18	Nahapetavan	0.17	Alvank	0.15	Kashuni	0.11		
Jrashen	0.19	Lusakn	0.18	Gagarin	0.17	Ushi	0.15	Karaberd	0.11		
Teghenik	0.19	Sotk	0.18	Urtsalanj	0.17	Lanjar	0.15	Lernagyugh	0.11		
Tsovinar	0.19	Katnajur	0.18	Lchavan	0.17	Aghvorik	0.15	Gnshik	0.11		
Bashgyugh	0.19	Kajaran	0.18	Paruyr Sevak	0.17	Verin Sasunik	0.15	Dzoraget	0.11		
Rya Taza	0.19	Akhpradzor	0.18	Pokr Sepasar	0.17	Geghakar	0.15	Lusadzor	0.11		
Dzoravank	0.19	Privolnoye	0.18	Chkalovka	0.17	Dzagikavan	0.15	Khachashen	0.11		
Sarahart	0.19	Mayisyan	0.18	Vank	0.17	Torunik	0.15	Nerqin Shorja	0.11		
Hayravanq	0.19	Jraber	0.18	Akhurik	0.17	Okhtar	0.15	Paghaghbyur	0.11		
Nor Kyanq	0.19	Norakert	0.18	Kakavasar	0.17	Semyonovka	0.15	Chermakavan	0.11		

Appendix 3.1.E-2. Effect of surrounding ecosystems on cooling capacity in settlements (CC)

Settlements in alphabetical order											
Abkes	0.023	Ardvi	0.003	Bardzravan	0.001	Dzoraget	0.023	Gyulagarak	0.001	Kakavadzor	-0.003
Abovyan	-0.011	Aregnadem	-0.005	Bardzruni	0.001	Dzoraghbyur	-0.003	Gyumri	-0.011	Kakavasars	-0.010
Abovyan	-0.009	Areguni	-0.002	Barekamavan	0.102	Dzoraglukh	0.000	Gyumri	-0.003	Kakhakn	0.000
Abovyan	-0.001	Areni	-0.002	Barepat	0.205	Dzoragyugh	-0.003	Haghartsin	0.016	Kalavan	0.156
Achajur	0.008	Arevabuyr	0.000	Bargushat	0.023	Dzoragyugh	-0.001	Haghat	0.049	Kamaris	-0.003
Acharkut	0.140	Arevadasht	-0.018	Basen	-0.001	Dzoragyugh	0.009	Haghtanak	0.001	Kamkhut	-0.015
Agarak	-0.004	Arevashat	0.000	Bashgyugh	-0.002	Dzorakap	-0.001	Hagvi	0.022	Kamo	-0.007
Agarak	-0.002	Arevashogh	-0.001	Batikyan	-0.021	Dzoranut	0.002	Hako	-0.035	Kanachut	0.000
Agarak	0.000	Arevik	0.000	Bavra	-0.001	Dzorashen	-0.003	Halidzor	0.001	Kanakeravan	-0.004
Agarak	0.015	Arevik	0.000	Bayandur	-0.001	Dzorastan	0.056	Hankavan	0.007	Kanch	-0.006
Agarakadzor	-0.001	Arevis	-0.049	Bazmaghbyur	-0.003	Dzoravank	0.043	Harich	-0.003	Kaniashir	0.000
Agarakavan	-0.001	Arevshat	-0.001	Bazum	0.008	Dzyunashogh	0.007	Hartagyugh	-0.001	Kapan	0.041
Aghavnadzor	-0.002	Arevut	-0.031	Bendik	0.028	Erkenants	0.017	Hartashen	-0.010	Kapan	0.043
Aghavnadzor	0.029	Argvand	0.000	Beniamin	-0.005	Fantan	0.000	Hartashen	0.000	Kaps	0.000
Aghavnatun	0.000	Argel	-0.003	Berd	0.018	Ferik	0.000	Hartavan	-0.003	Kaputan	-0.005
Aghavnnavank	0.021	Argina	0.000	Berdashen	-0.002	Fioletovo	0.001	Hatis	-0.001	Kapuyt	-0.049
Aghberk	-0.006	Arin	-0.001	Berdavan	0.001	Gagarin	-0.012	Hatsashen	-0.025	Karaberd	0.000
Aghin	-0.032	Arinj	-0.004	Berdik	0.000	Gai	0.000	Hatsavan	-0.009	Karaberd	0.018
Aghitu	-0.008	Arjhovit	0.018	Berdunk	-0.001	Gandzak	-0.061	Hatsavan	-0.061	Karadzji	-0.017
Aghnjadzor	0.027	Arjut	0.000	Berkaber	0.001	Gandzak	0.000	Hatsik	-0.002	Karadzor	-0.001
Aghtsq	-0.003	Armanis	0.001	Berkanush	0.000	Gandzaqar	0.077	Hatsik	0.000	Karaglukh	0.089
Aghvorik	-0.007	Arماش	-0.001	Berkarat	0.000	Gargar	0.000	Hatsikavan	-0.002	Karahunj	0.030
Ahnidzor	0.047	Armavir	-0.001	Bergashat	0.000	Garnahovit	-0.007	Hayanist	-0.002	Karakert	-0.004
Aigehovit	0.015	Armavir	-0.001	Bjni	-0.006	Garnarich	-0.011	Haykadzor	-0.004	Karakorum	0.109
Ajabaj	0.021	Arpeni	-0.014	Blagodarnoe	0.001	Garni	-0.009	Haykasar	0.000	Karashamb	-0.003
Akhlatyan	-0.004	Arpi	-0.005	Bnunis	0.005	Garni	-0.004	Haykashen	-0.002	Karashen	0.000
Akhpadzor	-0.002	Arpunk	0.000	Boloraberd	-0.060	Gavar	0.011	Haykavan	0.000	Karbi	-0.009
Akhta	-0.062	Arshaluys	0.000	Bovadzor	0.001	Geghadir	-0.002	Haykavan	0.000	Karchaghbyur	-0.001
Akhurik	0.000	Artabyunyk	0.117	Brnakot	-0.004	Geghadir	0.000	Hayravanq	-0.006	Karchevan	0.002
Akhuryan	0.000	Artamet	-0.004	Burastan	0.000	Geghadzor	0.000	Hayrenyats	0.000	Kard	0.021
Aknaghbyur	0.016	Artanish	-0.007	Burma	0.226	Geghakar	-0.012	Haytagh	0.000	Karenis	-0.005
Akналitch	0.000	Artashar	0.000	Buzhakan	-0.004	Geghakert	0.000	Herher	-0.008	Karin	0.000
Aknashen	0.000	Artashat	0.000	Byurakan	-0.002	Geghamabak	0.000	Hermon	-0.034	Karinj	0.002
Akner	0.001	Artashavan	-0.008	Byurakn	0.004	Geghamasar	-0.001	Hnaberd	-0.003	Karkop	0.008
Akner	0.017	Artavan	-0.002	Byurashat	-0.022	Geghamavan	-0.002	Hnaberd	0.000	Karmir Aghek	0.001
Akori	0.006	Artavaz	0.001	Byuravan	0.000	Geghanist	0.000	Hobardzi	0.000	Karmirgyugh	-0.008
Akunk	-0.011	Arteni	-0.002	Byureghavan	-0.013	Geghanist	0.000	Hoghmik	-0.006	Karmaqar	-0.004
Akunk	-0.005	Artik	-0.003	Chakaten	0.034	Geghanush	0.011	Horadis	-0.026	Karmrashen	-0.007
Akunk	0.000	Artimet	0.000	Chambarak	0.010	Geghard	-0.007	Horbategh	-0.025	Karmrashen	-0.001
Alagyaz	0.000	Artsni	0.004	Changli	-0.059	Gegharkunik	-0.002	Horbategh	0.086	Karmravan	-0.001
Alapars	-0.003	Artsvanik	0.000	Chapkut	0.031	Gegharot	0.000	Horom	-0.005	Karnut	-0.008
Alashkert	0.000	Artsvanist	0.001	Chapni	0.010	Geghasar	-0.007	Hors	0.178	Karut	0.021
Alaverdi	0.025	Aruch	-0.001	Charchakis	0.000	Geghashen	-0.016	Hovit	-0.010	Kasakh	-0.002
Alvank	-0.009	Arzakan	-0.010	Charentsavan	-0.004	Geghatap	0.014	Hovk	0.085	Kashuni	0.020
Alvar	-0.005	Arzni	-0.028	Chermakavan	0.017	Geghavank	0.022	Hovnadzor	0.009	Katchatchkut	0.009
Amaghu	-0.063	Ashnak	-0.022	Chinari	0.001	Geghavank	0.022	Hovtamej	0.000	Kathnakhyur	0.003
Amasia	-0.006	Ashotavan	-0.003	Chinchin	0.001	Geghhovit	-0.002	Hovtashat	0.000	Kathnarat	0.002
Amasia	0.000	Ashotk	-0.007	Chiva	-0.007	Geghi	0.019	Hovtashen	-0.002	Katnaghbyur	-0.011
Amberd	0.000	Ashtarak	0.000	Chkalov	0.003	Getahovit	0.006	Hovtashen	0.000	Katnaghbyur	0.025
Amoj	0.002	Astghadzor	0.000	Chkalovka	-0.011	Getamej	-0.003	Hovtun	0.000	Katnajur	-0.007
Amrakits	0.001	Atan	0.027	Chknagh	0.000	Getap	-0.014	Hovuni	-0.002	Katnarat	0.019
Andokavan	0.016	Atchanan	0.000	Chochkan	0.005	Getap	-0.001	Hrazdan	-0.002	Kavtchut	0.021
Angeghakot	-0.001	Avan	-0.011	Choratan	0.018	Getapnya	0.000	Hrazdan	0.004	Kayan	0.000
Aniavan	-0.001	Avazan	0.000	Dalar	0.000	Getargel	-0.001	Hushakert	0.000	Kayq	-0.012
Anipemza	-0.018	Avshar	0.000	Dalarik	-0.003	Getashen	0.000	Ijevan	0.017	Kechut	0.012
Antaramej	0.042	Avshen	0.000	Darakert	0.000	Getatagh	-0.002	Ijevanatun	-0.018	Keiti	-0.001
Antaramut	0.027	Aygabats	-0.005	Daranak	-0.008	Getavan	0.004	Irind	-0.008	Khachaghbyur	-0.013
Antarashat	0.064	Aygavan	-0.001	Darbas	-0.013	Getazat	0.000	Isahakyan	-0.004	Khachardzan	0.015
Antarashen	0.201	Aygedzor	0.026	Darbnik	0.000	Getik	0.005	Ishkhanasar	-0.010	Khachashen	0.015
Antaravan	0.014	Aygek	-0.001	Darik	-0.015	Getishen	0.082	Itsagar	0.010	Khachik	-0.062
Antarut	0.000	Aygeshat	-0.003	Darpas	-0.002	Getk	0.000	Jaghatsadzor	-0.004	Khachik	-0.008
Apaga	0.000	Aygeshat	0.000	Dasht	0.000	Gharibjanyan	-0.004	Jajur	-0.004	Khachpar	0.000
Aparan	-0.010	Aygestan	0.000	Dashtadem	-0.011	Ghazanchi	-0.006	Jajuravan	0.000	Khandakhach	-0.060
Apaven	0.004	Aygevan	0.000	Dashtadem	0.008	Ghazaravan	-0.007	Jamatun	-0.044	Khanjyan	0.000
Apnaghyugh	-0.002	Aygezard	-0.001	Dashtakar	-0.002	Ghukasavan	0.000	Jamshlu	0.000	Kharkov	-0.004
Aragats	-0.005	Aygut	0.006	Dashtavan	0.000	Ginevet	-0.001	Janfida	0.000	Khashtarak	0.007
Aragats	-0.001	Ayntap	0.000	Dastakert	-0.037	Gladzor	0.000	Jermuk	0.175	Khdrants	0.023
Aragatsavan	-0.003	Ayrk	0.000	David Bek	0.002	Gndevaz	-0.001	Jil	-0.002	Khnutsakh	0.001
Aragatsotn	-0.001	Azat	0.000	Davtashen	-0.014	Gnshik	-0.024	Jiliza	0.204	Khndzoresk	0.002
Aragyugh	-0.001	Azatamut	-0.001	Ddmasar	-0.032	Gogaran	-0.001	Jraber	-0.002	Khndzorut	0.080
Aradjadzor	0.043	Azatan	0.000	Ddmashen	-0.004	Gogavan	0.006	Jradzor	-0.001	Khnkoyan	-0.004
Araks	-0.005	Azatashen	0.000	Debet	0.006	Goghovit	-0.004	Jrahovit	-0.001	Khnutik	-0.055
Araksashen	-0.012	Azatavan	0.000	Debetavan	0.000	Goght	-0.012	Jrambar	-0.024	Khor Virap	-0.014
Aralanj	0.003	Azatek	0.003	Deghdzut	0.000	Goghtanik	-0.002	Jrapi	-0.003	Khordzor	0.023
Aralez	0.000	Aznvadzor	0.004	Dian	-0.009	Gokhth	-0.056	Jrarat	-0.016	Khoronk	0.000
Aramus	-0.001	Babikavan	0.005	Dilijan	0.138	Gomaran	0.008	Jrarat	-0.004	Khosrov	-0.057
Arapi	0.000	Bagaran	0.001	Dimitrov	0.000	Gomarants	0.024	Jrarat	0.000	Khot	0.000
Araqs	-0.001	Baghanis	0.032	Ditak	0.000	Gomk	-0.001	Jrabi	-0.003	Khnoznavar	0.015
Araqsavan	0.000	Baghrmryan	-0.009	Ditavan	0.010	Goravan	0.000	Jrashen	-0.005	Kirants	0.001
Ararat	-0.001	Baghrmryan	-0.001	Ditsmayri	0.021	Gorayk	-0.004	Jrashen	0.000	Kitsk	0.020
Ararat (village)	-0.001	Baghrmryan	0.000	Doghs	0.000	Gorgoch	0.287	Jrashen	0.000	Kobayr	0.354
Aratashen	0.000	Bagratashen	0.000	Dovegh	0.015	Goris	0.008	Jrvej	-0.001	Kochaqar	0.014
Arates	-0.025	Bagravan	-0.014	Dprabak	0.028	Gosh	0.132	Jujevan	0.115	Koghb	0.028
Aravus	0.019	Balahovit	-0.001	Dprevan	-0.001	Gribovedov	0.000	Kabakhlu	0.091	Koghbavan	-0.008
Arayi	-0.007	Balak	-0.003	Drakhtik	-0.017	Gtashen	-0.006	Kaghnut	0.011	Koghges	0.000
Arazap	0.000	Bambakashat	0.000	Dsegh	0.000	Gudemnis	0.038	Kaghsi	0.001	Kopoy Var	-0.003
Arbat	0.000	Bandivan	-0.001	Dvin	-0.001	Gugark	0.007	Kaghtsrashen	0.000	Kordon	-0.022
Archis	0.002	Bardzrashen	-0.046	Dzagikavan	0.016	Gusanagyugh	-0.007	Kajaran	0.006	Kornidzor	0.000
Ardenis	-0.006	Bardzrashen	-0.006	Dzithankov	-0.002	Gushar	-0.045	Kajarants	0.015	Kosh	-0.004

Kotayq	-0.002	Mets Sepsar	0.000	Paghakn	-0.013	Shinuhayr	0.001	Tsovagyugh	-0.001	Yeghegnavan	0.000
Koti	0.003	Metsadzor	-0.028	Pambak	-0.002	Shirak	-0.002	Tsovak	0.010	Yeghegnut	-0.001
Krasar	0.000	Metsamor	-0.003	Pambak	0.004	Shirakamut	-0.004	Tsovasar	-0.003	Yeghegnut	0.019
Krashen	-0.011	Metsamor	0.000	Parakar	-0.002	Shirakavan	0.000	Tsovard	-0.002	Yeghipatrush	-0.003
Kruglaja Shishka	0.004	Metsamoravan	-0.003	Parpi	-0.002	Shishkert	0.022	Tsovinar	-0.003	Yeghnajur	-0.020
Kuchak	-0.002	Metsavan	0.002	Partizak	-0.001	Shnogh	0.022	Ttujur	0.000	Yeghnik	-0.009
Kuris	0.008	Mgart	0.001	Paruyr Sevak	-0.020	Shoghakat	-0.004	Ttujur	0.012	Yeghvard	-0.002
Kurtan	0.000	Mijnatun	-0.002	Pemzashen	-0.003	Shoghakn	-0.001	Tufashen	0.000	Yeghvard	0.009
Kut	-0.002	Mikhayelovka	0.001	Petrovka	0.001	Shogheravan	-0.023	Tumanyan	0.061	Yelpin	-0.006
Kutakan	-0.005	Mirak	-0.004	Pokr Ayrum	0.009	Shramsak	-0.022	Ughedzor	-0.031	Yenokavan	0.031
Lanjaghbyur	-0.001	Mkhchyan	-0.001	Pokr Masrik	-0.001	Shrvnants	0.025	Ujan	-0.008	Yeranos	-0.008
Lanjanist	-0.037	Monteavan	-0.006	Pokr Sepsar	0.000	Shurnukh	0.003	Ujanis	0.054	Yeraskh	-0.007
Lanjar	-0.030	Mozrov	-0.017	Pokr Vedi	0.000	Shvanidzor	-0.010	Urasar	0.001	Yeraskhahun	0.000
Lanjazat	-0.005	Mrganush	0.000	Pokrashen	-0.002	Sipan	0.000	Urtsadzor	-0.004	Yerazgavors	0.000
Lanjik	-0.001	Mrgashat	0.000	Pogr Sariar	-0.001	Sipanik	0.000	Urtsalanj	-0.019	Yerevan	-0.004
Lchap	-0.002	Mrgashen	0.000	Por	-0.009	Sis	0.000	Urtsashen	-0.062	Yerizak	-0.022
Lchashen	-0.002	Mrgastan	0.000	Privolnoye	0.002	Sisavan	0.000	Urut	0.002	Yernjatap	0.000
Lchavan	-0.006	Mrgavan	0.000	Proshyan	0.000	Sisian	-0.012	Ushi	-0.020	Yervandashat	-0.003
Lchkadzor	0.019	Mrgavet	-0.001	Pshatavan	-0.001	Sizavet	0.000	Uyts	-0.008	Zangakatun	-0.004
Lehvaz	-0.001	Mughni	-0.001	Ptghavan	0.000	Small Glan	-0.053	Vagharshapat	-0.001	Zar	-0.005
Lejan	0.001	Musalier	0.000	Ptghni	-0.004	Smithavan	-0.005	Vaghashen	0.001	Zarinja	-0.002
Lenughi	0.000	Musayelyan	-0.001	Ptghunk	0.000	Solak	-0.004	Vaghatin	-0.010	Zarishat	-0.008
Lermontovo	0.000	Mutsk	0.000	Pukhrut	-0.017	Sorik	-0.034	Vaghatur	0.006	Zaritap	0.035
Lernadzor	0.006	Myasnikiyan	-0.001	Pushkino	0.007	Sotk	-0.001	Vahagnadzor	0.068	Zariver	0.000
Lernagog	-0.017	Nahapetavan	0.000	Pyunik	0.001	Spandaryan	-0.005	Vahagni	0.015	Zartokn	0.000
Lernagyugh	-0.018	Nalbandyan	0.000	Qajashen	-0.022	Spitak	-0.006	Vahan	0.001	Zedea	-0.005
Lernahovit	0.001	Narek	-0.003	Ranchpar	0.000	Srashen	0.007	Vahramaberd	-0.004	Zolaqar	-0.002
Lernajur	-0.031	Navur	0.019	Rind	-0.064	Stepanavan	0.051	Vahravar	0.025	Zorak	0.000
Lernakert	-0.006	Nerkin Bazmaberd	-0.006	Rind	-0.004	Surenavan	0.000	Vanadzor	0.014	Zorakan	0.005
Lernakert	-0.005	Nerkin Getashen	-0.002	Rya Taza	-0.001	Suser	-0.002	Vanadzor	0.015	Zorakert	-0.009
Lernamerdz	-0.002	Nerkin Giratagh	0.023	Sachanlu	-0.024	Svarants	0.007	Vanand	-0.007	Zoravan	0.000
Lernanist	-0.006	Nerkin Khndzoresk	0.000	Sadunts	0.000	Sverdlov	0.003	Vanand	0.033	Zovaber	-0.004
Lernantsq	-0.002	Nerkin Khotanan	0.003	Saghagyugh	0.013	Syunik	0.010	Vanashen	0.000	Zovasar	-0.004
Lernapar	-0.002	Nerkin Sasnashen	-0.004	Saghmosavan	-0.017	Sznak	0.015	Vanek	0.060	Zovashen	0.000
Lernapat	-0.004	Nerqin Hand	0.071	Salli	0.005	Tairov	0.000	Vanevan	0.000	Zovk	-0.003
Lernarot	-0.002	Nerqin Shorja	-0.020	Salut	-0.002	Talin	-0.018	Vank	0.009	Zovuni	-0.001
Lernavan	-0.002	Nigatun	-0.055	Salvard	-0.001	Talvorik	-0.009	Vardablur	-0.001	Zuygakhbyur	-0.004
Lernut	-0.014	Nigavan	0.000	Saragyugh	0.000	Tanahat	-0.057	Vardablur	0.007		
Lichk	-0.003	Nizami	0.000	Sarahart	-0.004	Tandzatap	0.011	Vardadzor	-0.004		
Lichk	0.001	Nor Amanos	-0.007	Sarakap	-0.020	Tandzaver	0.021	Vardaghybyur	-0.007		
Lor	-0.003	Nor Akhuryan	-0.009	Saralanj	-0.013	Tandzut	0.000	Vardahovit	0.000		
Lori Berd	0.000	Nor Armavir	0.000	Saralanj	-0.008	Taperakan	0.000	Vardanashen	0.000		
Lorut	0.001	Nor Artagers	0.000	Saralanj	-0.003	Taratumb	0.056	Vardanidzor	0.007		
Ltsen	-0.004	Nor Artamet	-0.001	Saralanj	0.000	Taronik	0.000	Vardaqar	-0.008		
Lukashin	-0.001	Nor Artik	-0.001	Saramej	-0.008	Tashir	0.008	Vardashat	-0.014		
Lusadzor	-0.010	Nor Astghaberd	0.039	Saranist	-0.053	Tashunt	0.000	Vardashen	0.000		
Lusadzor	0.005	Nor Aznaberd	0.323	Sarapat	-0.005	Tasik	-0.007	Vardavan	-0.050		
Lusaghbyur	-0.018	Nor Geghi	-0.011	Saratak	-0.006	Tatev	0.003	Vardavank	0.017		
Lusaghbyur	-0.007	Nor Gyugh	-0.006	Saratovka	0.002	Tatul	-0.010	Vardenik	-0.002		
Lusagyugh	-0.006	Nor Hachin	0.000	Saravan	-0.022	Tavrus	0.132	Vardenis	-0.008		
Lusagyugh	0.000	Nor Kesaria	0.000	Sarchapet	0.002	Tavshut	-0.004	Vardenis	0.000		
Lusahovit	0.045	Nor Khachakap	-0.002	Sardarapat	0.000	Tavush	0.023	Vardenut	-0.011		
Lusakert	-0.001	Nor Kharberd	-0.001	Sarigyugh	0.001	Tegh	0.001	Varser	-0.003		
Lusakn	-0.005	Nor Kyank	0.000	Sarnaghybyur	-0.024	Teghenik	-0.004	Vayk	-0.008		
Lusakunq	-0.001	Nor Kyanq	-0.001	Sarnaghybyur	-0.007	Tegher	-0.012	Vayk	0.013		
Lusarat	0.000	Nor Kyurin	-0.002	Sarnakunk	-0.001	Teghout	0.008	Vazashen	0.067		
Lusashogh	-0.015	Nor Ughi	0.000	Sarukhan	-0.002	Teghut	0.085	Vedi	-0.002		
Madina	-0.009	Nor Yedesia	-0.001	Sasunik	0.000	Tigranashen	-0.043	Vedi	0.000		
Makenis	-0.001	Nor Yerznka	-0.001	Sayat Nova	-0.001	Tkhkut	0.025	Verin Akhtala	0.038		
Malev	0.023	Norabak	-0.005	Semyonovka	-0.010	Tlik	-0.022	Verin Artashat	0.000		
Malishka	-0.004	Norabats	0.000	Sers	0.000	Tolors	-0.002	Verin Bazmaberd	-0.008		
Maralik	-0.001	Noraduz	-0.001	Sevaberd	-0.003	Torfavan	0.000	Verin Dvin	-0.001		
Margahovit	0.022	Norakert	-0.003	Sevakar	0.007	Torosgyugh	-0.001	Verin Getashen	-0.004		
Margara	0.000	Norakert	-0.001	Sevan	-0.001	Torunik	-0.029	Verin Giratagh	0.022		
Marmarashen	0.000	Noramarg	0.000	Sevazhayr	-0.024	Tretuq	-0.008	Verin Khotanan	0.032		
Marmarik	-0.006	Noramut	0.008	Sevkar	0.004	Tsaghkahovit	0.000	Verin Ptghni	0.000		
Marmashen	0.000	Norapat	0.000	Shaghap	-0.025	Tsaghkalanj	0.000	Verin Sasnashen	-0.005		
Martiros	-0.005	Norashen	-0.004	Shaghat	-0.001	Tsaghkassar	-0.002	Verin Sasunik	-0.015		
Marts	0.000	Norashen	-0.001	Shagik	-0.013	Tsaghkashen	-0.005	Verin Shorzha	-0.017		
Martuni	-0.004	Norashen	0.001	Shahumian	0.000	Tsaghkashen	-0.002	Verishen	0.005		
Martuni	0.110	Norashenik	0.007	Shahumyan	-0.007	Tsaghkavan	0.007	Vernashen	0.012		
Masis	-0.002	Noravan	-0.007	Shahumyan	0.023	Tsaghkunk	-0.004	Vocheti	0.022		
Masis	0.000	Noravan	0.000	Shahumyan	0.032	Tsaghkunk	0.000	Voghjaberd	-0.001		
Mastara	-0.010	Novoseltsovo	0.003	Shamb	-0.003	Tsaghkut	-0.008	Voghji	-0.003		
Mayakovski	-0.001	Noyakert	0.000	Shamiram	-0.002	Tsakhkaber	-0.006	Vorotan	-0.003		
Mayisyan	-0.002	Novemberyan	0.025	Shamlugh	0.160	Tsakhkadzor	0.193	Vorotan	0.004		
Mayisyan	-0.002	Nrnadzor	-0.022	Shamut	0.010	Tsakhkassar	-0.023	Voskehask	0.000		
Medovka	0.005	Nshavan	0.000	Shaqi	-0.003	Tsakhkashat	0.032	Voskehat	-0.009		
Meghradzor	-0.003	Nshkharq	-0.008	Shatin	0.070	Tsakhkots	-0.047	Voskehat	0.000		
Meghrashat	0.000	Nurnus	-0.010	Shatjrek	0.000	Tsakkar	-0.003	Voskepar	0.014		
Meghri	-0.011	Nzhdeh	-0.056	Shatvan	0.000	Tsamakassar	-0.018	Vosketap	0.000		
Megyahovit	0.008	Odzun	0.002	Shenatagh	-0.029	Tsapatagh	-0.005	Vosketas	-0.002		
Melikgyugh	0.001	Ohanavan	-0.019	Shenavan	-0.002	Tsater	0.002	Voskevan	0.019		
Merdzavan	0.000	Oghtar	0.015	Shenavan	-0.001	Tsav	0.022	Voskevaz	-0.003		
Mets Ayridja	-0.018	Orgov	-0.020	Shenavan	0.000	Tsghuk	0.000	Vostan	0.000		
Mets Ayrum	0.003	Oshakan	-0.002	Shenik	0.000	Tsghuni	-0.057	Yagdan	0.001		
Mets Masrik	-0.002	Othevan	-0.031	Shenkani	-0.001	Tsiatsan	0.000	Yegheg	0.040		
Mets Parni	-0.002	Paghaghbyur	0.011	Shgharshik	-0.019	Tsilkar	0.000	Yeghegis	0.018		
Mets Sariar	-0.004	Paghakan	0.030	Shikahogh	0.026	Tsoghamarg	-0.002	Yeghegnadzor	-0.002		

Settlements in ascending order of effect on CC

Rind	-0.064	Saghmosavan	-0.017	Vardaqaar	-0.008	Kosh	-0.004	Metsamor	-0.003	Nor Kyanq	-0.001
Amaghu	-0.063	Pukhrut	-0.017	Karnut	-0.008	Kharkov	-0.004	Salut	-0.002	Aragatsotn	-0.001
Urtsashen	-0.062	Drakhtik	-0.017	Koghbavan	-0.008	Agarak	-0.004	Akhpradzor	-0.002	Noradz	-0.001
Akhata	-0.062	Geghashen	-0.016	Vayk	-0.008	Nerkin Sasnashen	-0.004	Nerkin Getashen	-0.002	Norakert	-0.001
Khachik	-0.062	Jrarat	-0.016	Herher	-0.008	Ptghni	-0.004	Vosketas	-0.002	Jrahovit	-0.001
Gandzak	-0.061	Verin Sasunik	-0.015	Katnajur	-0.007	Karmraqaar	-0.004	Yeghegnadzor	-0.002	Zovuni	-0.001
Khandakhach	-0.060	Lusashogh	-0.015	Nor Amanos	-0.007	Rind	-0.004	Mijnatun	-0.002	Ararat	-0.001
Boloraberd	-0.060	Darik	-0.015	Geghasar	-0.007	Jrarat	-0.004	Jraber	-0.002	Angeghakot	-0.001
Changli	-0.059	Kamkhut	-0.015	Kamo	-0.007	Jajur	-0.004	Zarinja	-0.002	Nor Yedesia	-0.001
Khosrov	-0.057	Davtashen	-0.014	Artanish	-0.007	Khnkoyan	-0.004	Nor Kyurin	-0.002	Basen	-0.001
Tanahat	-0.057	Khor Virap	-0.014	Vardaghbyur	-0.007	Solak	-0.004	Parpi	-0.002	Vardablur	-0.001
Tsghuni	-0.057	Lernut	-0.014	Vanand	-0.007	Jaghatsadzor	-0.004	Oshakan	-0.002	Shenavan	-0.001
Gokhth	-0.056	Arpeni	-0.014	Noravan	-0.007	Shirakamut	-0.004	Geghhovit	-0.002	Karchaghbyur	-0.001
Nzhdeh	-0.056	Getap	-0.014	Ashotsk	-0.007	Isahakyan	-0.004	Sarukhan	-0.002	Vagharshapat	-0.001
Khnusik	-0.055	Vardashat	-0.014	Chiva	-0.007	Akhatlyan	-0.004	Darpas	-0.002	Karadzor	-0.001
Nigatun	-0.055	Bagraavan	-0.014	Ghazaravan	-0.007	Shoghakat	-0.004	Pambak	-0.002	Keti	-0.001
Saranist	-0.053	Byureghavan	-0.013	Karmrashen	-0.007	Ddmashen	-0.004	Shirak	-0.002	Musayelyan	-0.001
Small Glan	-0.053	Paghakn	-0.013	Garnahovit	-0.007	Gorayk	-0.004	Artavan	-0.002	Sarnakunk	-0.001
Vardavan	-0.050	Khachaghbyur	-0.013	Arayi	-0.007	Brnakot	-0.004	Vedi	-0.002	Hatis	-0.001
Arevis	-0.049	Darbas	-0.013	Gusanagyugh	-0.007	Kanakeravan	-0.004	Getatagh	-0.002	Azatamut	-0.001
Kapuyt	-0.049	Shagik	-0.013	Sarnaghbyur	-0.007	Haykadzor	-0.004	Lernarot	-0.002	Mayakovski	-0.001
Tsakhkots	-0.047	Saralanj	-0.013	Yeraskh	-0.007	Teghenik	-0.004	Mets Masrik	-0.002	Mkhchyan	-0.001
Bardzrashen	-0.046	Sisian	-0.012	Shahumyan	-0.007	Buzhakan	-0.004	Aghavnadzor	-0.002	Myasnikiyan	-0.001
Gushar	-0.045	Goght	-0.012	Lusaghbyur	-0.007	Zovasar	-0.004	Pokrashen	-0.002	Berdkunk	-0.001
Jamatun	-0.044	Tegher	-0.012	Tasik	-0.007	Tsaghkunk	-0.004	Berdashen	-0.002	Gndevaz	-0.001
Tigranashen	-0.043	Kayq	-0.012	Geghard	-0.007	Norashen	-0.004	Kotayq	-0.002	Arevshat	-0.001
Dastakert	-0.037	Gagarin	-0.012	Aghvorik	-0.007	Verin Getashen	-0.004	Bashgyugh	-0.002	Aragakavan	-0.001
Lanjanist	-0.037	Araksashen	-0.012	Nerkin Bazmaberd	-0.006	Garni	-0.004	Gegharkunik	-0.002	Aygek	-0.001
Hako	-0.035	Geghakar	-0.012	Spitak	-0.006	Goghovit	-0.004	Mayisyan	-0.002	Lukashin	-0.001
Sorik	-0.034	Avan	-0.011	Marmarik	-0.006	Ltsen	-0.004	Areguni	-0.002	Arin	-0.001
Hermon	-0.034	Chkalovka	-0.011	Tsakhkaber	-0.006	Artamet	-0.004	Geghamavan	-0.002	Nor Artamet	-0.001
Ddmasar	-0.032	Meghri	-0.011	Saratak	-0.006	Gharibjanyan	-0.004	Lchashen	-0.002	Mrgavet	-0.001
Aghin	-0.032	Akunk	-0.011	Bjni	-0.006	Mirak	-0.004	Haykashen	-0.002	Bayandur	-0.001
Lernajur	-0.031	Gyumri	-0.011	Ghazanchi	-0.006	Zuygakhbyur	-0.004	Vardenik	-0.002	Karmrashen	-0.001
Ughedzor	-0.031	Krashen	-0.011	Nor Gyugh	-0.006	Vardadzor	-0.004	Byurakan	-0.002	Yeghegnut	-0.001
Arevut	-0.031	Vardenut	-0.011	Amasia	-0.006	Zangakatun	-0.004	Goghtanik	-0.002	Aygavan	-0.001
Othevan	-0.031	Katnaghbyur	-0.011	Hoghmk	-0.006	Vahramaberd	-0.004	Shamiram	-0.002	Voghjaberd	-0.001
Lanjar	-0.030	Dashtadem	-0.011	Gtashen	-0.006	Malishka	-0.004	Lernavan	-0.002	Bavra	-0.001
Torunik	-0.029	Nor Geghi	-0.011	Ardenis	-0.006	Mets Sariar	-0.004	Lernantsq	-0.002	Dvin	-0.001
Shenatagh	-0.029	Abovyan	-0.011	Kanch	-0.006	Narek	-0.003	Agarak	-0.002	Sevan	-0.001
Arzni	-0.028	Garnarich	-0.011	Aghberk	-0.006	Aygeshat	-0.003	Mayisyan	-0.002	Ararat (village)	-0.001
Metsadzor	-0.028	Nurnus	-0.010	Lchavan	-0.006	Hatsavan	-0.003	Nor Khachakap	-0.002	Gogaran	-0.001
Horadis	-0.026	Tatul	-0.010	Lernakert	-0.006	Aragatsavan	-0.003	Yeghvard	-0.002	Agarakadzor	-0.001
Arates	-0.025	Lusadzor	-0.010	Yelpin	-0.006	Shaqi	-0.003	Kuchak	-0.002	Baghramyanyan	-0.001
Hatsashen	-0.025	Kakavasara	-0.010	Monteavan	-0.006	Lor	-0.003	Tsaghkasar	-0.002	Getargel	-0.001
Horbategh	-0.025	Hovit	-0.010	Lernanist	-0.006	Pemzashen	-0.003	Hovuni	-0.002	Araqs	-0.001
Shaghap	-0.025	Shvanidzor	-0.010	Bardzrashen	-0.006	Argel	-0.003	Mets Parni	-0.002	Lehvaz	-0.001
Jrambar	-0.024	Arzakan	-0.010	Lusagyugh	-0.006	Zovk	-0.003	Tsaghkashen	-0.002	Maralik	-0.001
Gnishik	-0.024	Ishkhanasar	-0.010	Hayravangh	-0.006	Vorotan	-0.003	Hrazdan	-0.002	Nor Kharberd	-0.001
Sachanlu	-0.024	Aparan	-0.010	Akunk	-0.005	Artik	-0.003	Hatsikavan	-0.002	Hartagyugh	-0.001
Sarnaghbyur	-0.024	Vaghatin	-0.010	Araks	-0.005	Metsamoravan	-0.003	Geghadir	-0.002	Abovyan	-0.001
Sevazhayr	-0.024	Hartashen	-0.010	Zedea	-0.005	Voghji	-0.003	Kasakh	-0.002	Tsovagyugh	-0.001
Tsakhkasar	-0.023	Mastara	-0.010	Kutakan	-0.005	Voskevaz	-0.003	Kut	-0.002	Aygezard	-0.001
Shogheravan	-0.023	Semyonovka	-0.010	Sarapat	-0.005	Kamaris	-0.003	Tsovazard	-0.002	Pogr Sariar	-0.001
Shramsk	-0.022	Yeghnik	-0.009	Zar	-0.005	Hartavan	-0.003	Shenavan	-0.002	Salvard	-0.001
Saravan	-0.022	Zorakert	-0.009	Aragats	-0.005	Balak	-0.003	Lernapar	-0.002	Balahovit	-0.001
Yerizak	-0.022	Por	-0.009	Tsaghkashen	-0.005	Karashamb	-0.003	Zolaqaar	-0.002	Karmraavan	-0.001
Nrnadzor	-0.022	Alvank	-0.009	Tsapatagh	-0.005	Meghhradzor	-0.003	Lchap	-0.002	Gomk	-0.001
Kordon	-0.022	Nor Akhuryan	-0.009	Martiros	-0.005	Jrarbi	-0.003	Masis	-0.002	Rya Taza	-0.001
Byurashat	-0.022	Talvorik	-0.009	Spandaryan	-0.005	Harich	-0.003	Jil	-0.002	Shoghakn	-0.001
Tlik	-0.022	Hatsavan	-0.009	Karenis	-0.005	Tsovinar	-0.003	Tolors	-0.002	Nor Yerzuka	-0.001
Qajashen	-0.022	Voskehat	-0.009	Beniamin	-0.005	Norakert	-0.003	Tsoghmagarg	-0.002	Dzorakap	-0.001
Ashnak	-0.022	Karbi	-0.009	Norabak	-0.005	Dzoragyugh	-0.003	Arteni	-0.002	Sotk	-0.001
Batikyan	-0.021	Garni	-0.009	Lernakert	-0.005	Saralanj	-0.003	Hayanist	-0.002	Lanjik	-0.001
Yeghnajur	-0.020	Madina	-0.009	Jrashen	-0.005	Dzorashen	-0.003	Dashtakar	-0.002	Mughni	-0.001
Paruyr Sevak	-0.020	Baghramyanyan	-0.009	Horom	-0.005	Getamej	-0.003	Apnagyugh	-0.002	Aruch	-0.001
Orgov	-0.020	Dian	-0.009	Smithavan	-0.005	Bazmaghbyur	-0.003	Parakar	-0.002	Aragyugh	-0.001
Ushi	-0.020	Abovyan	-0.009	Lanjazat	-0.005	Lichk	-0.003	Suser	-0.002	Aramus	-0.001
Sarakap	-0.020	Yeranos	-0.008	Aregnadem	-0.005	Yervandashat	-0.003	Hovtashen	-0.002	Getap	-0.001
Nerqin Shorja	-0.020	Daranak	-0.008	Kaputan	-0.005	Ashotavan	-0.003	Hatsik	-0.002	Pshatavan	-0.001
Urtsalanj	-0.019	Irind	-0.008	Verin Sasnashen	-0.005	Dalarik	-0.003	Dzithankov	-0.002	Armavir	-0.001
Shgharshik	-0.019	Zarishat	-0.008	Arpi	-0.005	Kakavadzor	-0.003	Areni	-0.002	Norashen	-0.001
Ohanavan	-0.019	Aghitu	-0.008	Alvar	-0.005	Jrapi	-0.003	Lernamerdz	-0.002	Makenis	-0.001
Lusaghbyur	-0.018	Saralanj	-0.008	Lusakn	-0.005	Gyumri	-0.003	Nor Artik	-0.001	Aragats	-0.001
ljevanatun	-0.018	Uyats	-0.008	Aygabats	-0.005	Hnaberd	-0.003	Lusakert	-0.001	Shaghat	-0.001
Arevadasht	-0.018	Tsaghkut	-0.008	Arinj	-0.004	Dzoraghbyur	-0.003	Pokr Masrik	-0.001	Armavir	-0.001
Anipemza	-0.018	Ujan	-0.008	Tavshut	-0.004	Alapars	-0.003	Geghamasar	-0.001	Armash	-0.001
Mets Ayridja	-0.018	Khachik	-0.008	Urtsadzor	-0.004	Tsakkar	-0.003	Dzoragyugh	-0.001	Verin Dvin	-0.001
Talin	-0.018	Tretuq	-0.008	Zovaber	-0.004	Aghtsq	-0.003	Partizak	-0.001	Ginevet	-0.001
Tsamakasar	-0.018	Vardenis	-0.008	Yerevan	-0.004	Tsovasar	-0.003	Sayat Nova	-0.001	Jradzor	-0.001
Lernagyugh	-0.018	Verin Bazmaberd	-0.008	Martuni	-0.004	Shamb	-0.003	Aniavan	-0.001	Lusakunq	-0.001
Lernagog	-0.017	Karmirgyugh	-0.008	Charentsavan	-0.004	Varser	-0.003	Shenkani	-0.001	Lanjaghbyur	-0.001
Karadzi	-0.017	Saramej	-0.008	Sarahart	-0.004	Yeghipatrush	-0.003	Jrvej	-0.001	Dprevank	-0.001
Mozrov	-0.017	Artashavan	-0.008	Karakert	-0.004	Kopoy Var	-0.003	Bandivan	-0.001	Arevashogh	-0.001
Verin Shorzh	-0.017	Nshkharq	-0.008	Lernapat	-0.004	Sevaberd	-0.003	Torosgyugh	-0.001	Dasht	0.000

Nor Kyank	0.000	Nalbandyan	0.000	Hatsik	0.000	Karmir Aghek	0.001	Dzoragyugh	0.009	Dzoraget	0.023
Noramarg	0.000	Saragyugh	0.000	Haykasar	0.000	Lorut	0.001	Pokr Ayrum	0.009	Malev	0.023
Ferik	0.000	Nor Ughi	0.000	Haykavan	0.000	Sarigyugh	0.001	Katchatchkut	0.009	Gomarants	0.024
Tsilkar	0.000	Aknashen	0.000	Hayrenyats	0.000	Ursar	0.001	Hovnadzor	0.009	Alaverdi	0.025
Shenavan	0.000	Zartonk	0.000	Haytagh	0.000	Fioletovo	0.001	Yeghvard	0.009	Novemberyan	0.025
Arap	0.000	Shahumian	0.000	Hovtamej	0.000	Akner	0.001	Vank	0.009	Vahravar	0.025
Kaghtsrashen	0.000	Mrganush	0.000	Hovtashen	0.000	Khntsakh	0.001	Syunik	0.010	Shrenants	0.025
Getazat	0.000	Byuravan	0.000	Hushakert	0.000	Shinuhayr	0.001	Chambarak	0.010	Katnaghbyur	0.025
Nahapetavan	0.000	Marmarashen	0.000	Jajuravan	0.000	Urut	0.002	Chapni	0.010	Tkhkut	0.025
Jrrat	0.000	Geghanist	0.000	Jamshlu	0.000	Tsater	0.002	Itsaqar	0.010	Aygedzor	0.026
Khanjyan	0.000	Amberd	0.000	Jrashen	0.000	Karinj	0.002	Tsovak	0.010	Shikahogh	0.026
Antarut	0.000	Arevik	0.000	Kanachut	0.000	Metsavan	0.002	Ditavan	0.010	Atan	0.027
Sis	0.000	Aralez	0.000	Kaniashir	0.000	Karchevan	0.002	Shamut	0.010	Aghnjadzor	0.027
Sizavet	0.000	Kayan	0.000	Kaps	0.000	Saratovka	0.002	Tandzatap	0.011	Antaramut	0.027
Hovtashat	0.000	Sipanik	0.000	Khachpar	0.000	David Bek	0.002	Kaghnut	0.011	Dprabak	0.028
Akunk	0.000	Lenugh	0.000	Khoronk	0.000	Sarchapet	0.002	Geghanush	0.011	Koghb	0.028
Hnaberd	0.000	Mrgashat	0.000	Kornidzor	0.000	Amoj	0.002	Paghaghbyur	0.011	Bendik	0.028
Proshyan	0.000	Griboyedov	0.000	Krasar	0.000	Kathnarat	0.002	Gavar	0.011	Aghavnadzor	0.029
Mets Sepasar	0.000	Shatjrek	0.000	Lusagyugh	0.000	Khndzoresk	0.002	Ttujur	0.012	Paghakan	0.030
Gegharot	0.000	Shenik	0.000	Margara	0.000	Dzoramat	0.002	Vernashen	0.012	Karahanj	0.030
Arpunk	0.000	Vostan	0.000	Masis	0.000	Archis	0.002	Kechut	0.012	Yenokavan	0.031
Gladzor	0.000	Torfavan	0.000	Meghrashat	0.000	Odzun	0.002	Saghagyugh	0.013	Chapkut	0.031
Sers	0.000	Alashkert	0.000	Mrgastan	0.000	Privolnoye	0.002	Vayk	0.013	Verin Khotanan	0.032
Avshen	0.000	Berkanush	0.000	Musaler	0.000	Arvi	0.003	Antaravan	0.014	Baghanis	0.032
Janfida	0.000	Goravan	0.000	Mutsk	0.000	Shurnukh	0.003	Kochaqar	0.014	Shahumyan	0.032
Deghdzut	0.000	Azatan	0.000	Nerkin Khndzoresk	0.000	Novoseltsovo	0.003	Geghatap	0.014	Tsakhkashat	0.032
Norabats	0.000	Gandzak	0.000	Norapat	0.000	Nerkin Khotanan	0.003	Vanadzor	0.014	Vanand	0.033
Tsghuk	0.000	Baghramyan	0.000	Noravan	0.000	Aralanj	0.003	Voskepar	0.014	Chakaten	0.034
Akhurik	0.000	Voskehat	0.000	Noyakert	0.000	Kathnakhpyur	0.003	Kajarants	0.015	Zaritat	0.035
Voskehask	0.000	Metsamor	0.000	Pokr Sepasar	0.000	Tatev	0.003	Sznak	0.015	Gudemnis	0.038
Tandzut	0.000	Dalar	0.000	Ptghavan	0.000	Khkalov	0.003	Vahagni	0.015	Verin Akhtala	0.038
Vosketap	0.000	Marmashen	0.000	Sadunts	0.000	Mets Ayrum	0.003	Dovegh	0.015	Nor Astghaberd	0.039
Vedi	0.000	Nshavan	0.000	Shatvan	0.000	Azatek	0.003	Vanadzor	0.015	Yegheg	0.040
Gai	0.000	Aygestan	0.000	Taronik	0.000	Sverdlov	0.003	Agarak	0.015	Kapan	0.041
Ayrk	0.000	Shirakavan	0.000	Vanashen	0.000	Koti	0.003	Okhtar	0.015	Antaramej	0.042
Avazan	0.000	Aygeshat	0.000	Yernjatap	0.000	Artsni	0.004	Khachardzan	0.015	Kapan	0.043
Hovtun	0.000	Tsaghkunk	0.000	Zariver	0.000	Aznvadzor	0.004	Khachashen	0.015	Dzoravank	0.043
Vardashen	0.000	Yeraskhahun	0.000	Hobardzi	0.000	Hrazdan	0.004	Khnoznavar	0.015	Aradzor	0.043
Astghadzor	0.000	Geghakert	0.000	Kakhakn	0.000	Getavan	0.004	Aigehovit	0.015	Lusahovit	0.045
Geghadzor	0.000	Darakert	0.000	Lori Berd	0.000	Pambak	0.004	Dzagikavan	0.016	Ahnidzor	0.047
Dashtavan	0.000	Ttujur	0.000	Gargar	0.000	Vorotan	0.004	Andokavan	0.016	Haghpat	0.049
Nizami	0.000	Sardarapat	0.000	Atchanan	0.000	Kruglaja Shishka	0.004	Aknaghbyur	0.016	Stepanavan	0.051
Arjut	0.000	Nor Artagers	0.000	Karashen	0.000	Sevkar	0.004	Haghartsin	0.016	Ujanis	0.054
Nor Hachin	0.000	Argina	0.000	Marts	0.000	Apaven	0.004	Akner	0.017	Taratumb	0.056
Aygevan	0.000	Arazap	0.000	Hartashen	0.000	Byurakn	0.004	Chermakavan	0.017	Dzorastan	0.056
Artashat	0.000	Fantan	0.000	Tashtun	0.000	Lusadzor	0.005	Erkenants	0.017	Vanek	0.060
Akhuryan	0.000	Vardanashen	0.000	Artsvanik	0.000	Zorakan	0.005	Vardavank	0.017	Tumanyan	0.061
Surenavan	0.000	Apaga	0.000	Agarak	0.000	Babikavan	0.005	Ijevan	0.017	Antarashat	0.064
Yerazgavors	0.000	Tsiatsan	0.000	Koghesh	0.000	Medovka	0.005	Arjhovit	0.018	Vazashen	0.067
Zovashen	0.000	Saralanj	0.000	Ashtarak	0.000	Getik	0.005	Choratan	0.018	Vahagnadzor	0.068
Ptghunk	0.000	Burastan	0.000	Lermontovo	0.000	Verishen	0.005	Berd	0.018	Shatin	0.070
Vanevan	0.000	Pokr Vedi	0.000	Kurtan	0.000	Chochkan	0.005	Karaberd	0.018	Nerqin Hand	0.071
Nor Armavir	0.000	Yeghegnavan	0.000	Khot	0.000	Bnunis	0.005	Yeghegis	0.018	Gandzaqar	0.077
Verin Ptghni	0.000	Jrashen	0.000	Dsegh	0.000	Salli	0.005	Lchkadzor	0.019	Khndzorut	0.080
Akmalitch	0.000	Sisavan	0.000	Vahan	0.001	Aygut	0.006	Geghi	0.019	Getishen	0.082
Lusarat	0.000	Berkarat	0.000	Gyulagarak	0.001	Kajaran	0.006	Voskevan	0.019	Hovk	0.085
Dzoraglukh	0.000	Sasunik	0.000	Artsvanist	0.001	Akori	0.006	Aravus	0.019	Teghut	0.085
Tairov	0.000	Tapetakan	0.000	Mgart	0.001	Lernadzor	0.006	Navur	0.019	Hovbategh	0.086
Arevashat	0.000	Avshar	0.000	Lernahovit	0.001	Vaghatur	0.006	Katnarat	0.019	Karaglukh	0.089
Amasia	0.000	Argavand	0.000	Haghtanak	0.001	Debet	0.006	Yeghegnut	0.019	Kabaklu	0.091
Karaberd	0.000	Bambakashat	0.000	Lichk	0.001	Gogavan	0.006	Kashuni	0.020	Barekamavan	0.102
Merdzavan	0.000	Aghavnatun	0.000	Norashen	0.001	Getahovit	0.006	Kitsk	0.020	Karakorum	0.109
Charchakis	0.000	Aratashen	0.000	Armanis	0.001	Vardanidzor	0.007	Aghavnnavank	0.021	Martuni	0.110
Tsaghkahovit	0.000	Arbat	0.000	Mikheyelovka	0.001	Norashenik	0.007	Ditsmayri	0.021	Jujevan	0.115
Bagratashen	0.000	Arevik	0.000	Bardzruni	0.001	Dzyunashogh	0.007	Ajabaj	0.021	Artabyunk	0.117
Verin Artashat	0.000	Arshaluys	0.000	Bagaran	0.001	Srashen	0.007	Kavtchut	0.021	Tavrus	0.132
Arevabyur	0.000	Artashar	0.000	Melikgyugh	0.001	Svarants	0.007	Tandzaver	0.021	Gosh	0.132
Haykavan	0.000	Artime	0.000	Halidzor	0.001	Hankavan	0.007	Kard	0.021	Dilijan	0.138
Karin	0.000	Ayntap	0.000	Tegh	0.001	Pushkino	0.007	Karut	0.021	Acharkut	0.140
Doghs	0.000	Azat	0.000	Chinari	0.001	Khashtarak	0.007	Shishkert	0.022	Kalavan	0.156
Zorak	0.000	Azatashen	0.000	Artavaz	0.001	Tsaghkavan	0.007	Margahovit	0.022	Shamlugh	0.160
Alagyaz	0.000	Azatavan	0.000	Yagdan	0.001	Sevark	0.007	Verin Giratagh	0.022	Jermuk	0.175
Tsaghkalanj	0.000	Berdik	0.000	Vaghashen	0.001	Gugark	0.007	Vocheti	0.022	Hors	0.178
Araqsavan	0.000	Berqashat	0.000	Blagodarnoe	0.001	Vardablur	0.007	Tsav	0.022	Tsakhkadzor	0.193
Ranchpar	0.000	Chknagh	0.000	Kirants	0.001	Karkop	0.008	Hagvi	0.022	Antarashen	0.201
Vardenis	0.000	Darbnik	0.000	Bovadzor	0.001	Bazum	0.008	Geghavank	0.022	Jiliza	0.204
Nigavan	0.000	Debetavan	0.000	Amrakits	0.001	Achajur	0.008	Shnogh	0.022	Barepat	0.205
Zoravan	0.000	Dimitrov	0.000	Pyunik	0.001	Goris	0.008	Geghavank	0.022	Burma	0.226
Nor Kesaria	0.000	Ditak	0.000	Bardzravan	0.001	Gomaran	0.008	Nerkin Giratagh	0.023	Gorgoch	0.287
Vardahovit	0.000	Geghadir	0.000	Petrovka	0.001	Teghout	0.008	Abkes	0.023	Nor Aznaberd	0.323
Sipan	0.000	Geghamabak	0.000	Chinchin	0.001	Noramut	0.008	Bargushat	0.023	Kobayr	0.354
Mrgavan	0.000	Geghanist	0.000	Berkaber	0.001	Kuris	0.008	Khdrants	0.023		
Mrgashen	0.000	Getapnya	0.000	Berdavan	0.001	Dashtadem	0.008	Shahumyan	0.023		
Getashen	0.000	Getk	0.000	Lejan	0.001	Megvahovit	0.008	Tavush	0.023		
Tufashen	0.000	Ghukasavan	0.000	Kaghshi	0.001	Tashir	0.008	Khordzor	0.023		

Appendix 3.1.E-3. Changes in CC in settlements from 2017 to 2023

Settlements in alphabetical order														
Settlement	CC in 2023	CC in 2017	2023-2017 CC	2023-2017 %		CC in 2023	CC in 2017	2023-2017 CC	2023-2017 %		CC in 2023	CC in 2017	2023-2017 CC	2023-2017 %
Abkes	0.12	0.12	0	0	Arazap	0.24	0.25	-0.01	-2.96	Bagratashen	0.22	0.22	0	-0.72
Abovyan	0.18	0.18	0.01	4.64	Arbat	0.21	0.22	-0.01	-2.68	Bagravan	0.18	0.17	0.01	4.16
Abovyan	0.21	0.22	-0.02	-6.92	Archis	0.2	0.19	0.01	2.85	Balahovit	0.21	0.21	0	-0.23
Abovyan	0.19	0.18	0.01	5.81	Ardenis	0.16	0.16	0.01	4.66	Balak	0.19	0.2	0	-1.62
Achajur	0.2	0.2	0.01	3.16	Ardvi	0.19	0.19	0	0.54	Bambakashat	0.27	0.28	-0.01	-3.15
Acharkut	0.28	0.26	0.02	8.46	Aregnadem	0.17	0.16	0.01	5.21	Bandivan	0.16	0.16	0.01	3.38
Agarak	0.2	0.2	0	0.14	Areguni	0.2	0.19	0	0.92	Bardzrashen	0.19	0.17	0.02	13.08
Agarak	0.21	0.2	0.01	3.48	Areni	0.21	0.21	0	0.35	Bardzrashen	0.1	0.09	0	0.95
Agarak	0.17	0.19	-0.03	-14.04	Arevabuyr	0.21	0.2	0.01	4.33	Bardzravan	0.21	0.19	0.02	8.59
Agarak	0.21	0.23	-0.02	-7.4	Arevadasht	0.09	0.09	0	1.79	Bardzruni	0.21	0.21	0	1.83
Agarakadzor	0.21	0.21	0	0.59	Arevashat	0.22	0.26	-0.04	-14.22	Barekamavan	0.25	0.23	0.03	12.23
Agarakavan	0.2	0.19	0.01	3.51	Arevashogh	0.2	0.2	0	0.35	Barepat	0.35	0.32	0.04	11.94
Aghavnadzor	0.21	0.21	0	0.13	Arevik	0.2	0.2	0	1.18	Bargushat	0.12	0.12	0	0
Aghavnadzor	0.19	0.2	-0.01	-3.55	Arevik	0.24	0.25	-0.01	-3.16	Basen	0.2	0.2	0	0.29
Aghavnatun	0.23	0.25	-0.03	-10.64	Arevis	0.11	0.14	-0.03	-23.12	Bashgyugh	0.19	0.2	-0.01	-3.77
Aghavnavank	0.14	0.17	-0.02	-13.82	Arevshat	0.21	0.22	-0.01	-6.73	Batikyan	0.09	0.09	0	0
Aghberk	0.17	0.17	0	-1.08	Arevut	0.15	0.15	0	-0.93	Bavra	0.19	0.19	0	-0.12
Aghin	0.13	0.14	-0.01	-6.16	Argavand	0.27	0.28	-0.02	-6.25	Bayandur	0.2	0.19	0.01	4.86
Aghitu	0.19	0.2	0	-1.89	Argel	0.2	0.19	0	1.64	Bazmaghbyur	0.2	0.19	0.01	4.01
Aghnjadzor	0.23	0.22	0.01	2.89	Argina	0.21	0.21	0	-0.1	Bazum	0.21	0.18	0.02	12.57
Aghtsq	0.2	0.19	0.01	2.73	Arin	0.21	0.2	0.01	5.97	Bendik	0.12	0.13	-0.01	-10.62
Aghvorik	0.15	0.14	0.01	6.8	Arinj	0.18	0.19	-0.01	-4.54	Beniamin	0.18	0.17	0	1.63
Ahnidzor	0.22	0.19	0.03	17.85	Arjhovit	0.21	0.18	0.03	15.87	Berd	0.2	0.22	-0.01	-5.59
Aigehovit	0.22	0.21	0	0.85	Arjut	0.19	0.18	0	1.96	Berdashen	0.16	0.15	0.01	5.12
Ajabaj	0.12	0.12	0	0	Armanis	0.19	0.19	0	1.13	Berdavan	0.2	0.2	0	-1.13
Akhlatyan	0.2	0.19	0	2.5	Armash	0.22	0.23	-0.01	-2.23	Berdik	0.22	0.23	-0.01	-3.33
Akhpradzor	0.18	0.18	0.01	2.96	Armavir	0.23	0.23	0	-1.69	Berdkunk	0.2	0.19	0.01	3.4
Akhra	0.09	0.09	0	0	Armavir	0.25	0.26	-0.01	-5.08	Berkaber	0.19	0.19	0	-0.99
Akhurik	0.17	0.17	0	0.54	Arpeni	0.13	0.13	0.01	4.19	Berkanush	0.23	0.23	-0.01	-3.84
Akhuryan	0.19	0.19	0	0.75	Arpi	0.19	0.19	0	-2.16	Berkarat	0.18	0.18	0	-0.78
Aknaghbyur	0.22	0.2	0.02	11.49	Arpunk	0.19	0.19	0	1.98	Berqashat	0.23	0.24	-0.01	-5.64
Aknalitch	0.21	0.23	-0.01	-6.42	Arshaluys	0.22	0.24	-0.02	-6.99	Bjini	0.19	0.18	0	1.9
Aknashen	0.22	0.23	-0.01	-3.63	Artabuynk	0.32	0.37	-0.05	-14.33	Blagodarne	0.24	0.23	0.01	2.81
Akner	0.19	0.19	0	1.06	Artamet	0.23	0.22	0.01	3.83	Bnunis	0.21	0.2	0.01	4.33
Akner	0.2	0.2	0	1.14	Artanish	0.18	0.17	0	2.62	Boloraberd	0.09	0.09	0	-2.32
Akori	0.18	0.17	0.01	5.82	Artashar	0.23	0.24	-0.01	-5.23	Bovadzor	0.27	0.17	0.1	59.71
Akunk	0.2	0.19	0	1.7	Artashat	0.22	0.23	0	-1.47	Brnakot	0.2	0.2	0	-0.7
Akunk	0.18	0.17	0	1.66	Artashavan	0.17	0.16	0.01	6.72	Burastan	0.23	0.24	-0.01	-5.58
Akunk	0.18	0.17	0.01	5.11	Artavan	0.2	0.2	0.01	3.52	Burma	0.37	0.37	0	-0.29
Alagyaz	0.18	0.18	0	-0.67	Artavaz	0.19	0.2	0	-1.44	Buzhakan	0.19	0.19	0	1.45
Alapars	0.19	0.19	0	1.45	Arteni	0.21	0.2	0.01	3.42	Byurakan	0.2	0.2	0	1.71
Alashkert	0.23	0.24	-0.01	-4.33	Artik	0.19	0.18	0.01	2.88	Byurakn	0.18	0.17	0.01	4.08
Alaverdi	0.18	0.16	0.02	15.59	Artimet	0.25	0.27	-0.02	-6.43	Byurashat	0.06	0.06	0	0
Alvank	0.15	0.18	-0.03	-14.83	Artsni	0.18	0.16	0.02	9.56	Byuravan	0.22	0.23	-0.01	-6.33
Alvar	0.17	0.16	0	1.58	Artsvanik	0.21	0.21	0	0.67	Byureghavan	0.17	0.17	0	-1.66
Amaghu	0.09	0.09	0	0	Artsvanist	0.2	0.2	0	1.2	Chakaten	0.22	0.21	0.01	2.84
Amasia	0.16	0.15	0.01	5.88	Aruch	0.24	0.23	0	1.93	Chambarak	0.21	0.18	0.02	12.93
Amasia	0.25	0.27	-0.02	-7.69	Arzakan	0.17	0.17	0.01	3.85	Changli	0.09	0.09	0	0
Amberd	0.23	0.25	-0.03	-10.58	Arzni	0.13	0.14	-0.01	-9.98	Chapkut	0.12	0.13	-0.01	-7.21
Amoj	0.23	0.24	-0.01	-5.87	Ashnak	0.17	0.17	0	-0.04	Chapni	0.17	0.2	-0.03	-14.03
Amrakits	0.23	0.18	0.05	25.76	Ashotavan	0.21	0.21	0	0.16	Charchakis	0.2	0.2	0	-0.09
Andokavan	0.15	0.19	-0.04	-22.58	Ashotsk	0.15	0.15	0	3.31	Charentsavan	0.19	0.18	0.01	4.3
Angeghakot	0.21	0.2	0	1.43	Ashtarak	0.22	0.23	-0.01	-3.75	Chermakavan	0.11	0.11	0	-3.12
Aniavan	0.2	0.19	0.01	4.15	Astghadzor	0.2	0.19	0	1.61	Chinari	0.22	0.22	0	-0.51
Anipemza	0.17	0.17	0	1.76	Atan	0.18	0.17	0.01	8.68	Chinchin	0.2	0.2	0	-0.5
Antaramej	0.23	0.2	0.02	11.77	Atchanan	0.22	0.22	-0.01	-2.55	Chiva	0.2	0.21	0	-1.4
Antaramut	0.19	0.17	0.03	17.29	Avan	0.18	0.17	0.01	2.97	Chkalov	0.18	0.16	0.03	18.09
Antarashat	0.25	0.24	0.01	6.17	Avazan	0.18	0.18	0	2.42	Chkalovka	0.17	0.18	-0.01	-5.77
Antarashen	0.34	0.32	0.03	8.14	Avshar	0.22	0.23	-0.01	-4.03	Chknagh	0.19	0.19	0	0.15
Antaravan	0.1	0.1	0	0	Avshen	0.19	0.18	0	2.51	Chochkan	0.18	0.17	0	1.81
Antarut	0.21	0.2	0	0.35	Aygabats	0.18	0.18	0.01	3.38	Choratan	0.19	0.18	0.01	5.33
Apaga	0.22	0.24	-0.01	-6.2	Aygavan	0.22	0.23	-0.01	-5.23	Dalar	0.21	0.21	0	-0.02
Aparan	0.17	0.16	0.01	4.42	Aygedzor	0.13	0.15	-0.02	-11.4	Dalarik	0.19	0.19	0.01	4.51
Apaven	0.18	0.14	0.04	30.53	Aygek	0.29	0.31	-0.02	-6.01	Darakert	0.21	0.23	-0.01	-4.71
Apnaghyugh	0.2	0.19	0	1.89	Aygeshat	0.24	0.25	-0.01	-3.9	Daranak	0.18	0.18	0	-1.68
Aragats	0.18	0.18	0	0.45	Aygeshat	0.2	0.21	-0.01	-5.21	Darbas	0.18	0.19	-0.01	-4.36
Aragats	0.23	0.24	0	-1.39	Aygestan	0.23	0.24	-0.01	-4.94	Darbnik	0.23	0.24	-0.01	-4.56
Aragatsavan	0.21	0.22	-0.01	-4.16	Aygevan	0.25	0.26	-0.01	-3.98	Darik	0.12	0.13	-0.01	-5.89
Aragatsotn	0.22	0.23	-0.01	-5.47	Aygezard	0.22	0.22	0	-1.68	Darpas	0.19	0.19	0	-0.65
Aragyugh	0.2	0.2	0	1.48	Aygut	0.17	0.15	0.02	10.28	Dasht	0.22	0.23	-0.01	-3.42
Aradjadzor	0.22	0.22	0	0.07	Ayntap	0.21	0.22	0	-0.96	Dashtadem	0.19	0.19	0	1.1
Araks	0.19	0.23	-0.03	-14.76	Ayrk	0.17	0.16	0	2.64	Dashtadem	0.15	0.11	0.04	35.18
Araksashen	0.14	0.12	0.02	13.36	Azat	0.18	0.17	0.01	3.79	Dashtakar	0.21	0.23	-0.03	-11.08
Aralanj	0.19	0.19	0.01	3.88	Azatamat	0.21	0.2	0.01	6.62	Dashtavan	0.21	0.21	0	-0.31
Aralez	0.22	0.23	-0.02	-6.97	Azatan	0.19	0.19	0	1.84	Dastakert	0.13	0.13	0	1.52
Aramus	0.2	0.2	0.01	3.82	Azatashen	0.21	0.23	-0.01	-5.59	David Bek	0.21	0.21	0	-0.58
Arapi	0.2	0.19	0	1.68	Azatavan	0.22	0.23	-0.01	-3.62	Davtashen	0.18	0.18	-0.01	-3.84
Araqs	0.21	0.21	0	-2.18	Azatek	0.22	0.23	-0.01	-5.19	Ddmasar	0.15	0.15	0	-1.72
Araqsavan	0.23	0.24	-0.01	-4.22	Aznvadzor	0.18	0.17	0.01	7.79	Ddmashen	0.19	0.19	0.01	3.24
Ararat	0.21	0.2	0.01	4.11	Babikavan	0.19	0.19	0	1.2	Debet	0.2	0.19	0.01	4.55
Ararat (village)	0.21	0.22	0	-1.6	Bagaran	0.21	0.24	-0.03	-13.76	Debetavan	0.22	0.22	0.01	3.2
Aratashen	0.22	0.23	-0.01	-6.12	Baghanis	0.21	0.19	0.02	10.27	Deghdzut	0.21	0.22	0	-1.68
Arates	0.1	0.1	0	0	Baghramyan	0.22	0.23	-0.01	-4.75	Dian	0.19	0.18	0.01	3.27
Aravus	0.13	0.15	-0.02	-15.35	Baghramyan	0.17	0.14	0.04	25.99	Dilijan	0.3	0.28	0.02	7.94
Arayi	0.19	0.18	0.01	6.35	Baghramyan	0.22	0.22	-0.01	-3.42	Dimitrov	0.21	0.22	-0.01	-3.4

Ditak	0.22	0.22	0	-1.27	Gomaran	0.24	0.16	0.09	56.17	Jrapi	0.2	0.2	0	0.41
Ditavan	0.21	0.21	0	-1.38	Gomarants	0.12	0.12	0	0	Jrarat	0.19	0.19	0	0.91
Ditsmayri	0.13	0.16	-0.03	-16.68	Gomk	0.21	0.19	0.02	13.21	Jrarat	0.16	0.17	-0.01	-3.02
Doghs	0.25	0.27	-0.02	-6.74	Goravan	0.22	0.21	0	1.53	Jrarat	0.21	0.22	-0.01	-5.86
Dovegh	0.18	0.19	-0.01	-4.24	Gorayk	0.17	0.16	0.01	4.97	Jrarbi	0.21	0.24	-0.03	-12.41
Dprabak	0.19	0.17	0.02	10.89	Gorgoch	0.41	0.4	0.01	1.95	Jrashen	0.22	0.22	-0.01	-2.51
Dprevank	0.23	0.26	-0.03	-11.14	GORIS	0.21	0.21	0	0.51	Jrashen	0.24	0.25	-0.01	-2.48
Drakhtik	0.15	0.15	0	0.07	Gosh	0.28	0.25	0.04	14.62	Jrashen	0.19	0.18	0.01	2.73
Dsegh	0.2	0.2	0	-0.05	Griboyedov	0.26	0.27	-0.02	-5.66	Jrvej	0.21	0.19	0.02	10.13
Dvin	0.21	0.21	0	-2.05	Gtashen	0.17	0.16	0.01	4.71	Jujevan	0.28	0.29	-0.01	-2.15
Dzagikavan	0.15	0.16	-0.01	-4.89	Gudemnis	0.17	0.32	-0.16	-48.41	Kabaklu	0.18	0.18	0	-1.87
Dzithankov	0.2	0.2	0	0.13	Gugark	0.19	0.18	0.01	3.04	Kaghnut	0.22	0.21	0	0.8
Dzoraget	0.11	0.11	0.01	6.39	Gusanagyugh	0.17	0.16	0.01	4.98	Kaghsi	0.2	0.19	0.01	2.72
Dzoraghybyur	0.18	0.17	0.01	6.24	Gushar	0.08	0.08	0	0	Kaghtsrashen	0.21	0.22	-0.01	-3.41
Dzoraglukh	0.2	0.2	0	0.12	Gyulagarak	0.21	0.2	0	1.28	Kajaran	0.18	0.18	0	-1.42
Dzoragyugh	0.21	0.19	0.02	10.43	Gyumri	0.17	0.17	0	0.24	Kajarants	0.14	0.14	0	0.2
Dzoragyugh	0.19	0.19	0	1.85	Gyumri	0.19	0.19	0	0.36	Kakavadzor	0.2	0.2	0	0.78
Dzoragyugh	0.18	0.18	0.01	3.11	Haghartsin	0.2	0.19	0.01	4.5	Kakavasars	0.17	0.19	-0.02	-11.03
Dzorakap	0.2	0.2	0	0.29	Haghpat	0.22	0.18	0.04	24.72	Kakhakn	0.18	0.18	0	0.26
Dzoramat	0.19	0.18	0.01	5.62	Haghtanak	0.2	0.19	0.01	3.33	Kalavan	0.31	0.24	0.07	29.06
Dzorashen	0.19	0.19	0	-0.53	Hagvi	0.19	0.19	0	-0.43	Kamaris	0.2	0.19	0	2.44
Dzorastan	0.23	0.2	0.03	12.41	Hako	0.14	0.17	-0.03	-15.75	Kamkhut	0.15	0.15	0	-2.11
Dzoravank	0.19	0.2	-0.01	-5.61	Halidzor	0.21	0.2	0.01	2.6	Kamo	0.18	0.18	0	0.54
Dzyunashogh	0.18	0.16	0.02	12.19	Hankavan	0.18	0.18	0	-1.05	Kanachut	0.22	0.22	0	-0.81
Erkenants	0.14	0.17	-0.02	-14.71	Harich	0.17	0.17	0	1.14	Kanakeravan	0.19	0.22	-0.03	-12.75
Fantan	0.2	0.19	0.01	2.7	Hartagyugh	0.18	0.18	0.01	3.92	Kanch	0.2	0.2	0	-1.73
Ferik	0.22	0.22	0	1.75	Hartashen	0.26	0.25	0.01	3.67	Kaniashir	0.19	0.18	0.01	5.52
Fioletovo	0.2	0.2	0	-0.87	Hartashen	0.15	0.15	0	-0.39	Kapan	0.21	0.2	0	0.7
Gagarin	0.17	0.17	0	2.56	Hartavan	0.19	0.18	0.01	3.54	Kapan	0.21	0.2	0	0.77
Gai	0.23	0.25	-0.02	-6.45	Hatis	0.19	0.19	0	1.4	Kaps	0.19	0.19	0	0.18
Gandzak	0.2	0.2	0	0.38	Hatsashen	0.16	0.16	0	-1.31	Kaputan	0.19	0.19	0.01	2.86
Gandzak	0.09	0.09	0	0	Hatsavan	0.2	0.2	0	1.08	Kapuyt	0.1	0.25	-0.15	-60.77
Gandzaqar	0.23	0.21	0.02	11.33	Hatsavan	0.18	0.18	0	0.48	Karaberd	0.19	0.19	0	-1.19
Gargar	0.21	0.2	0.01	3.29	Hatsik	0.23	0.24	-0.01	-4.39	Karaberd	0.11	0.1	0.01	10.94
Garnahovit	0.17	0.17	0	-0.34	Hatsik	0.19	0.19	0	0.73	Karadzi	0.13	0.16	-0.04	-22.48
Garnarich	0.14	0.15	0	-3.34	Hatsikavan	0.18	0.18	0	0.25	Karadzor	0.19	0.19	0	-0.21
Garni	0.19	0.19	0	1.2	Hayanist	0.21	0.2	0	1.7	Karaglukh	0.28	0.3	-0.01	-4.84
Garni	0.2	0.2	0	2.21	Haykadzor	0.19	0.19	0	0.09	Karahunj	0.23	0.21	0.01	7.02
Gavar	0.19	0.18	0.01	5.75	Haykasar	0.2	0.2	0	-0.5	Karakert	0.19	0.18	0.01	4.89
Geghadir	0.2	0.2	0	0.32	Haykashen	0.21	0.24	-0.03	-12.26	Karakorum	0.19	0.16	0.03	19.16
Geghadir	0.21	0.2	0.01	2.62	Haykavan	0.2	0.2	0	0.41	Karashamb	0.2	0.2	0	1.56
Geghadzor	0.18	0.18	0	0.66	Haykavan	0.22	0.23	-0.01	-2.95	Karashen	0.22	0.22	0	0.77
Geghakar	0.15	0.13	0.02	17.27	Hayravanq	0.19	0.19	0	0.6	Karbi	0.16	0.16	0	1.14
Geghakert	0.22	0.25	-0.03	-11.27	Hayrenyats	0.19	0.19	0	0.18	Karchaghybyur	0.2	0.2	0	0.43
Geghamabak	0.17	0.17	0	-0.31	Haytagh	0.22	0.22	-0.01	-3.5	Karchevan	0.21	0.21	0	-1.92
Geghamasar	0.19	0.18	0	1.7	Herher	0.19	0.17	0.02	13.35	Kard	0.12	0.12	0	0
Geghamavan	0.19	0.19	0	0.02	Hermon	0.13	0.14	-0.01	-9.84	Karenis	0.19	0.18	0.01	2.78
Geghanist	0.2	0.2	0	0.51	Hnaberd	0.18	0.18	0	-0.14	Karin	0.21	0.22	-0.01	-4.46
Geghanist	0.21	0.21	0	1.59	Hnaberd	0.2	0.24	-0.05	-19.57	Karinj	0.19	0.18	0.01	4.48
Geghanush	0.19	0.2	-0.01	-5.36	Hobardzi	0.21	0.21	0	-0.58	Karkop	0.14	0.11	0.03	24.77
Geghard	0.19	0.19	0	-0.35	Hoghmik	0.18	0.18	0	1.35	Karmir Aghek	0.22	0.23	-0.01	-6.28
Gegharkunik	0.19	0.19	0	-0.85	Horadis	0.1	0.1	0	0	Karmirgyugh	0.18	0.18	0	-0.28
Gegharot	0.19	0.19	0	1.8	Horbategh	0.28	0.25	0.03	10.72	Karmraqr	0.17	0.17	0	-1.57
Geghasar	0.18	0.17	0	1.08	Horbategh	0.1	0.1	0	0	Karmrashen	0.2	0.2	0	0.24
Geghashen	0.17	0.17	0	1.06	Horom	0.18	0.17	0	1.71	Karmrashen	0.18	0.18	0	0.32
Geghatap	0.1	0.1	0	0	Hors	0.36	0.31	0.05	16.22	Karmravan	0.19	0.19	0	1.36
Geghavank	0.12	0.12	0	0	Hovit	0.18	0.17	0	2.04	Karnut	0.18	0.17	0.01	3.5
Geghavank	0.12	0.12	0	0.3	Hovk	0.25	0.22	0.04	17.03	Karut	0.12	0.12	0	0
Geghhovit	0.19	0.19	0	0.46	Hovnadzor	0.14	0.1	0.04	37.62	Kasakh	0.2	0.19	0.01	5.21
Geghi	0.14	0.15	-0.01	-8.55	Hovtamej	0.22	0.23	-0.01	-5.6	Kashuni	0.11	0.11	0	0
Getahovit	0.2	0.19	0.01	3.55	Hovtashat	0.21	0.21	0	0.07	Katchatchkut	0.14	0.15	-0.01	-8.98
Getamej	0.19	0.18	0.01	6.38	Hovtashen	0.21	0.21	0	0.24	Kathnakhpyur	0.2	0.18	0.02	9.17
Getap	0.22	0.23	-0.01	-3.06	Hovtashen	0.17	0.17	0	0.15	Kathnarat	0.18	0.18	0	0.95
Getap	0.18	0.17	0.01	5.15	Hovtun	0.16	0.16	0.01	3.51	Katnaghbyur	0.22	0.2	0.02	11.76
Getapnya	0.21	0.21	0	0	Hovuni	0.19	0.19	0	0.04	Katnaghbyur	0.18	0.18	0	0.2
Getargel	0.2	0.19	0.01	6.74	Hrazdan	0.17	0.17	0	2.85	Katnajur	0.18	0.18	0.01	3.51
Getashen	0.25	0.26	-0.01	-4.85	Hrazdan	0.18	0.17	0	2.55	Katnarat	0.13	0.12	0.01	5.92
Getatagh	0.2	0.2	0	0.75	Hushakert	0.24	0.24	0	-0.83	Kavtchut	0.13	0.15	-0.02	-14.05
Getavan	0.18	0.16	0.02	12.32	Ijevan	0.21	0.2	0.01	7.16	Kayan	0.26	0.22	0.04	19.12
Getazat	0.21	0.21	0	0.39	Ijevanatun	0.12	0.11	0.01	12.82	Kayq	0.15	0.15	0	3.16
Getik	0.18	0.18	0	1.06	Irind	0.18	0.17	0.01	5.76	Kechut	0.21	0.18	0.03	14.61
Getishen	0.18	0.13	0.05	36.79	Isahakyan	0.2	0.2	0	0.99	Keti	0.19	0.19	0	-0.48
Getk	0.19	0.19	0	0.18	Ishkhanasar	0.19	0.18	0	2.35	Khachaghybyur	0.16	0.16	0	0.79
Gharibjanyan	0.19	0.19	0	0.07	Itsaqar	0.2	0.16	0.04	21.75	Khachardzan	0.18	0.17	0.01	6.24
Ghazanchi	0.16	0.16	0	2.83	Jaghatsadzor	0.19	0.17	0.01	6.98	Khachashen	0.11	0.11	0.01	5.04
Ghazaravan	0.18	0.17	0.01	7.2	Jajur	0.19	0.19	0	-1.4	Khachik	0.2	0.19	0.01	5.07
Ghukasavan	0.22	0.23	-0.01	-4.87	Jajuravan	0.19	0.18	0.01	3.42	Khachik	0.09	0.09	0	0
Ginevet	0.22	0.22	0	-2.17	Jamatun	0.07	0.07	0	0	Khachpar	0.21	0.21	0	-0.24
Gladzor	0.22	0.21	0.01	2.94	Jamshlu	0.18	0.18	0	-1.12	Khandakhach	0.09	0.09	0	0
Gndevaz	0.21	0.2	0	1.47	Janfida	0.23	0.24	-0.01	-2.16	Khanjyan	0.24	0.25	-0.01	-2.47
Gnishik	0.11	0.12	-0.01	-5.89	Jermuk	0.32	0.33	-0.01	-3.05	Kharkov	0.2	0.19	0.01	5.49
Gogaran	0.19	0.19	0	-0.63	Jil	0.19	0.19	0	0.75	Khastarak	0.2	0.2	0	2.29
Gogavan	0.16	0.12	0.04	32.54	Jiliza	0.31	0.3	0.01	2.61	Khdrants	0.14	0.16	-0.02	-14.32
Goghovit	0.18	0.18	0	1.71	Jrabar	0.18	0.18	0	-1.11	Khndzoresk	0.21	0.2	0.01	6.48
Goght	0.18	0.17	0.01	5.1	Jradzor	0.2	0.19	0.01	4.47	Khndzoresk	0.21	0.2	0	1.19
Goghtanik	0.2	0.19	0.01	2.75	Jrahovit	0.2	0.22	-0.02	-7.34	Khndzorut	0.29	0.29	0	0.06
Gokhth	0.09	0.09	0	0	Jrambar	0.13	0.12	0.01	10.54	Khnkoyan	0.18	0.17	0	2.41

Khnutik	0.09	0.09	0	0	Martuni	0.19	0.19	0	0.94	Norashen	0.2	0.2	0	2.52
Khor Virap	0.14	0.24	-0.1	-40.1	Martuni	0.28	0.27	0.02	7.15	Norashen	0.22	0.22	0	-1.35
Khordzor	0.12	0.12	0	0	Masis	0.2	0.2	0	-0.08	Norashen	0.19	0.19	0	2.09
Khoronk	0.22	0.24	-0.02	-7.89	Masis	0.21	0.22	-0.01	-3.27	Norashenik	0.22	0.22	0	-1.07
Khosrov	0.09	0.09	0	0	Mastara	0.19	0.18	0	2.07	Noravan	0.19	0.19	0	1.46
Khot	0.23	0.23	0.01	2.46	Mayakovski	0.2	0.18	0.01	7.31	Noravan	0.26	0.28	-0.02	-5.5
Khoznavar	0.16	0.16	0	-0.61	Mayisyan	0.21	0.26	-0.05	-19.69	Novoseltsovo	0.18	0.18	0	2.18
Kirants	0.2	0.2	0	0.83	Mayisyan	0.18	0.18	0	-0.47	Noyakert	0.23	0.23	-0.01	-2.35
Kitsk	0.12	0.12	0	0	Medovka	0.22	0.21	0.01	4.28	Noyemberyan	0.21	0.21	0	0.32
Kobayr	0.44	0.46	-0.02	-3.65	Meghradzor	0.19	0.19	0	0.36	Nrnadzor	0.06	0.06	0	0
Kochaqar	0.1	0.1	0	0	Meghrashat	0.2	0.2	0	-0.05	Nshavan	0.22	0.24	-0.01	-5.85
Koghb	0.2	0.19	0.01	4.95	Meghri	0.14	0.14	0.01	3.64	Nshkharq	0.17	0.16	0.01	7.17
Koghavan	0.2	0.27	-0.07	-27.59	Megvahovit	0.13	0.12	0.02	15.43	Nurnus	0.18	0.18	0	2.7
Koghes	0.21	0.21	0	-0.1	Melikgyugh	0.19	0.19	0	0.16	Nzhdeh	0.09	0.1	-0.01	-9.33
Kopoy Var	0.15	0.09	0.06	65.21	Merdzavan	0.21	0.22	-0.01	-2.87	Odzun	0.2	0.19	0	1.94
Kordon	0.09	0.09	0	0	Mets Ayridja	0.12	0.16	-0.04	-23.66	Ohanavan	0.15	0.13	0.02	13.26
Kornidzor	0.21	0.22	-0.01	-4.06	Mets Ayrum	0.24	0.24	0	1.24	Okhtar	0.15	0.13	0.01	11.07
Kosh	0.19	0.19	0	-0.82	Mets Masrik	0.19	0.19	0	0	Orgov	0.15	0.15	0.01	3.59
Kotayq	0.19	0.19	0.01	4.26	Mets Parni	0.17	0.17	0	-0.47	Oshakan	0.22	0.21	0.01	3.86
Koti	0.19	0.21	-0.02	-7.77	Mets Sariar	0.18	0.17	0.02	9.79	Othevan	0.14	0.15	-0.01	-4.85
Krasar	0.18	0.18	0	-0.33	Mets Sepasar	0.19	0.19	0	-0.18	Paghaghbyur	0.11	0.1	0.01	9.13
Krashen	0.17	0.17	-0.01	-3.76	Metsadzor	0.12	0.13	-0.01	-6.86	Paghakan	0.11	0.11	0	1.24
Kruglaja Shishka	0.17	0.15	0.02	13.3	Metsamor	0.21	0.24	-0.04	-14.56	Paghakn	0.12	0.12	0	1.74
Kuchak	0.19	0.19	0	2.42	Metsamor	0.22	0.23	-0.01	-4.48	Pambak	0.19	0.19	0	1.71
Kuris	0.19	0.2	-0.01	-5.08	Metsamoravan	0.21	0.2	0.01	2.86	Pambak	0.18	0.18	0	1.91
Kurtan	0.2	0.2	0	2.36	Metsavan	0.19	0.19	0	1.25	Parakar	0.21	0.2	0.01	4.03
Kut	0.17	0.17	0.01	3.01	Mgart	0.21	0.21	0	1.09	Parpi	0.2	0.19	0.01	6.5
Kutakan	0.16	0.16	0	-0.26	Mijnatun	0.18	0.19	-0.01	-3.96	Partizak	0.23	0.18	0.05	28.49
Lanjaghbyur	0.2	0.2	0	1.04	Mikhayelovka	0.22	0.19	0.03	18.27	Paruyr Sevak	0.17	0.16	0.01	8.57
Lanjanist	0.14	0.13	0.01	8.53	Mirak	0.13	0.09	0.04	41.56	Pemzashen	0.19	0.19	0.01	2.97
Lanjar	0.15	0.15	0	0	Mkhchyan	0.22	0.24	-0.02	-8.24	Petrovka	0.21	0.17	0.03	19.89
Lanjazat	0.18	0.19	-0.01	-6.02	Monteavan	0.21	0.26	-0.05	-18.41	Pokr Ayrum	0.16	0.14	0.02	13.44
Lanjik	0.2	0.2	0	-0.12	Mozrov	0.18	0.18	0	-1.52	Pokr Masrik	0.18	0.18	0	0.4
Lchap	0.2	0.2	0	0.6	Mrganush	0.22	0.23	-0.01	-3.54	Pokr Sepasar	0.17	0.17	0	-0.03
Lchashen	0.19	0.19	0	1.13	Mrgashat	0.22	0.23	0	-1.87	Pokr Vedi	0.22	0.22	0	-1.68
Lchavan	0.17	0.17	0	-0.11	Mrgashen	0.22	0.24	-0.02	-7.75	Pokrashen	0.18	0.18	0	-0.01
Lchkadzor	0.21	0.18	0.02	12.14	Mrgastan	0.25	0.26	-0.01	-4.97	Pogr Sariar	0.2	0.19	0	1.38
Lehvaz	0.21	0.21	0	1.53	Mrgavan	0.22	0.23	-0.01	-5.34	Por	0.2	0.18	0.02	10.07
Lejan	0.21	0.2	0.01	4.92	Mrgavet	0.22	0.24	-0.02	-8	Privolnoye	0.18	0.17	0.01	4.59
Lenughi	0.26	0.27	-0.02	-6.07	Mughni	0.21	0.2	0.01	3.77	Proshyan	0.22	0.22	0	-0.15
Lermontovo	0.2	0.2	0	-1.55	Musaler	0.23	0.25	-0.02	-8	Pshatavan	0.25	0.26	-0.01	-4.56
Lernadzor	0.19	0.2	-0.01	-3.38	Musayelyan	0.18	0.17	0.01	4.81	Ptghavan	0.21	0.2	0	1.59
Lernagog	0.1	0.09	0.01	16.86	Mutsk	0.21	0.2	0	2.1	Ptghni	0.18	0.17	0.02	9.31
Lernagyugh	0.11	0.11	0.01	7.44	Myasnikyan	0.23	0.23	0	-1.8	Ptghunk	0.22	0.21	0.01	2.82
Lernahovit	0.2	0.18	0.02	12.21	Nahapetavan	0.17	0.17	0	-0.39	Pukhrut	0.12	0.11	0.01	6.97
Lernajur	0.09	0.08	0.01	9.97	Nalbandyan	0.23	0.24	-0.01	-3.23	Pushkino	0.19	0.19	0.01	3.06
Lernakert	0.19	0.19	0	0.67	Narek	0.19	0.2	-0.01	-3.59	Pyunik	0.19	0.19	0	0.57
Lernakert	0.17	0.16	0	3.02	Navur	0.2	0.17	0.03	14.61	Qajashen	0.09	0.09	0	0
Lernamerdz	0.24	0.25	-0.01	-3.47	Nerkin Bazmaberd	0.2	0.19	0.01	2.82	Ranchpar	0.21	0.21	0	0.48
Lernanist	0.18	0.17	0.01	3.82	Nerkin Getashen	0.2	0.19	0.01	5.43	Rind	0.09	0.09	0	0
Lernantsq	0.19	0.19	0	0.27	Nerkin Giratagh	0.12	0.12	0	0	Rind	0.21	0.21	-0.01	-2.71
Lernapar	0.18	0.18	0	2.04	Nerkin Khndzoresk	0.21	0.21	0	0	Rya Taza	0.19	0.19	0	1.12
Lernapat	0.18	0.17	0	1.77	Nerkin Khotanan	0.2	0.18	0.03	14.27	Sachanlu	0.09	0.09	0	0
Lernarot	0.19	0.19	0	2.11	Nerkin Sasnashen	0.2	0.19	0	1.51	Sadunts	0.2	0.2	0	-0.07
Lernavan	0.19	0.19	0.01	3.9	Nerqin Hand	0.24	0.28	-0.03	-11.18	Saghagyugh	0.1	0.1	0.01	6.27
Lernut	0.17	0.17	0	-0.95	Nerqin Shorja	0.11	0.11	0	-2.25	Saghmosavan	0.16	0.15	0	1.59
Lichk	0.2	0.2	0	1.01	Nigmatun	0.08	0.08	0	0	Salli	0.21	0.22	-0.01	-5.56
Lichk	0.21	0.21	0	0.1	Nigavan	0.2	0.2	0	0.77	Salut	0.18	0.18	0	-0.47
Lori	0.2	0.2	0	0.61	Nizami	0.22	0.23	-0.02	-6.77	Salvard	0.21	0.21	0	0.59
Lori Berd	0.22	0.2	0.02	10.44	Nor Amanos	0.19	0.2	-0.01	-4.53	Saragyugh	0.19	0.19	0	1.15
Lorut	0.19	0.19	0	2.02	Nor Akhuryan	0.16	0.15	0	1.46	Sarahart	0.19	0.18	0.01	3
Ltsen	0.2	0.18	0.02	11.17	Nor Armavir	0.23	0.24	-0.01	-4.03	Sarakap	0.16	0.16	0	-0.21
Lukashin	0.24	0.24	0	1.12	Nor Artages	0.24	0.25	-0.01	-4.38	Saralanj	0.16	0.15	0.01	3.34
Lusadzor	0.2	0.2	0	1.39	Nor Artamet	0.21	0.22	-0.01	-2.95	Saralanj	0.2	0.19	0.01	2.81
Lusadzor	0.11	0.11	0	3.14	Nor Artik	0.2	0.2	0	1.31	Saralanj	0.18	0.18	0	0.78
Lusaghbyur	0.17	0.17	0.01	4.74	Nor Astghaberd	0.14	0.12	0.02	14.43	Saralanj	0.17	0.18	0	-1.12
Lusaghbyur	0.16	0.16	0	1.56	Nor Aznaberd	0.5	0.44	0.06	13.34	Saramej	0.18	0.17	0	2.1
Lusagyugh	0.18	0.18	0	1.97	Nor Geghi	0.18	0.18	0	1	Saranist	0.09	0.08	0	3.82
Lusagyugh	0.22	0.25	-0.03	-11.05	Nor Gyugh	0.2	0.19	0.01	4.39	Sarapat	0.18	0.17	0.01	5.5
Lusahovit	0.22	0.2	0.03	13.65	Nor Hachin	0.21	0.21	0	-0.24	Saratak	0.18	0.18	0	1.63
Lusakert	0.19	0.18	0	1.34	Nor Kesaria	0.22	0.24	-0.02	-8	Saratovka	0.21	0.2	0.01	5.68
Lusakn	0.18	0.16	0.02	11.72	Nor Khachakap	0.2	0.2	0	0.62	Saravan	0.16	0.14	0.02	17.66
Lusakunq	0.18	0.18	0	0.71	Nor Kharberd	0.21	0.23	-0.02	-7.18	Sarchapet	0.18	0.18	0	1.38
Lusarat	0.22	0.24	-0.01	-6.02	Nor Kyank	0.22	0.24	-0.02	-9.24	Sardarapat	0.22	0.23	-0.01	-4.02
Lusashogh	0.16	0.15	0	1.1	Nor Kyanq	0.19	0.19	0	1.43	Sarigyugh	0.2	0.21	-0.01	-3.76
Madina	0.17	0.17	0	1.8	Nor Kyurin	0.22	0.26	-0.04	-16.27	Sarnaghbyur	0.19	0.18	0	1.85
Makenis	0.2	0.19	0.01	3.29	Nor Ughi	0.21	0.24	-0.03	-11.76	Sarnaghbyur	0.09	0.1	0	-1.39
Malev	0.12	0.12	0	0	Nor Yedesia	0.22	0.24	-0.02	-6.75	Sarnakunk	0.18	0.17	0.01	6.23
Malishka	0.21	0.21	0	1.81	Nor Yerznka	0.25	0.25	0	-1.29	Sarukhan	0.19	0.19	0	1.2
Maralik	0.2	0.2	0	0.39	Norabak	0.18	0.18	0	-0.63	Sasunik	0.21	0.21	0	-0.97
Margahovit	0.21	0.19	0.02	8.5	Norabats	0.22	0.24	-0.03	-11.03	Sayat Nova	0.2	0.22	-0.01	-5.65
Margara	0.22	0.23	-0.02	-6.47	Noraduz	0.2	0.2	0	0.46	Semyonovka	0.15	0.18	-0.04	-18.99
Marmarashen	0.21	0.22	0	-1.13	Norakert	0.18	0.18	0	-1.76	Sers	0.21	0.21	0	0.57
Marmarik	0.17	0.16	0.01	5.26	Norakert	0.21	0.22	-0.01	-6.58	Sevaberd	0.19	0.19	0	-1.54
Marmashen	0.2	0.2	0	0.25	Noramarg	0.22	0.23	-0.01	-4.4	Sevakar	0.18	0.17	0.01	6.18
Martiros	0.2	0.19	0.01	3.82	Noramut	0.13	0.11	0.02	21.65	Sevan	0.18	0.17	0	2.69
Marts	0.2	0.2	0	-0.15	Norapat	0.22	0.23	-0.01	-4.69	Sevzhayr	0.1	0.12	-0.02	-13.91

Sevkar	0.2	0.2	0	1.41	Torunik	0.15	0.14	0.01	6.65	Verin Dvin	0.21	0.22	-0.01	-4.1
Shaghap	0.16	0.16	0	0.34	Tretuq	0.16	0.16	0	0.05	Verin Getashen	0.2	0.19	0	2.22
Shaghat	0.21	0.21	0	0.79	Tsaghkahovit	0.2	0.19	0	0.53	Verin Giratagh	0.12	0.12	0	0
Shagik	0.13	0.14	-0.02	-11.76	Tsaghkalanj	0.32	0.31	0.01	1.62	Verin Khotanan	0.22	0.19	0.04	19.37
Shahumian	0.22	0.23	-0.01	-2.41	Tsaghkasar	0.2	0.2	0	-1.2	Verin Ptghni	0.21	0.2	0	2.29
Shahumyan	0.18	0.2	-0.02	-11.77	Tsaghkashen	0.19	0.18	0.01	3.17	Verin Sasnashen	0.19	0.18	0	2.15
Shahumyan	0.22	0.21	0.01	4.95	Tsaghkashen	0.19	0.19	0	0.32	Verin Sasunik	0.15	0.15	0	2.39
Shahumyan	0.12	0.12	0	0.25	Tsaghkavan	0.2	0.2	0	-0.18	Verin Shorzha	0.12	0.14	-0.02	-15.7
Shamb	0.21	0.2	0	1.98	Tsaghkunk	0.21	0.22	-0.01	-4.35	Verishen	0.21	0.2	0.01	3.2
Shamiram	0.24	0.24	0	0.89	Tsaghkunk	0.17	0.17	0.01	4.98	Vernashen	0.22	0.22	0	0.78
Shamlugh	0.29	0.26	0.02	9.4	Tsaghkut	0.14	0.14	0	0.74	Vocheti	0.12	0.12	0	0
Shamut	0.19	0.19	0	-0.71	Tsakhkaber	0.18	0.18	0	1.05	Voghjaberd	0.21	0.2	0.01	3.4
Shaqi	0.19	0.19	0	1.4	Tsakhkadzor	0.35	0.37	-0.02	-6.74	Voghji	0.18	0.18	0	1.38
Shatin	0.27	0.25	0.02	7.3	Tsakhkasar	0.09	0.09	0	0	Vorotan	0.19	0.17	0.02	12.49
Shatjrek	0.2	0.2	0	0.5	Tsakhkashat	0.18	0.17	0.02	10.29	Vorotan	0.17	0.12	0.05	38.07
Shatvan	0.2	0.2	0	-0.49	Tsakhkots	0.08	0.08	0	0	Voskehask	0.19	0.19	0	1.96
Shenatagh	0.15	0.14	0	0.79	Tsakkhar	0.2	0.19	0	1.88	Voskehat	0.22	0.24	-0.02	-9.3
Shenavan	0.2	0.2	0	0.48	Tsamakasar	0.17	0.17	0	1.1	Voskehat	0.16	0.15	0.01	9.47
Shenavan	0.24	0.26	-0.02	-9.31	Tsapatagh	0.18	0.18	0	0.73	Voskepar	0.21	0.2	0.01	6.11
Shenavan	0.2	0.2	0	0.51	Tsater	0.2	0.2	0	-0.22	Vosketap	0.22	0.23	-0.01	-3.44
Shenik	0.24	0.25	-0.01	-3.1	Tsav	0.22	0.23	-0.02	-7.01	Vosketas	0.18	0.17	0.01	6.45
Shenkani	0.18	0.17	0	2.49	Tsghuk	0.19	0.17	0.01	6.7	Voskevan	0.21	0.2	0.01	4.61
Shgharshik	0.16	0.16	0	-1.02	Tsghuni	0.09	0.09	0	0	Voskevez	0.21	0.21	0	-0.55
Shikahogh	0.21	0.25	-0.04	-17.37	Tsiatsan	0.21	0.21	0	-0.38	Vostan	0.22	0.23	-0.01	-4.32
Shinuhayr	0.21	0.21	0.01	2.81	Tsilkar	0.19	0.19	0	0.6	Yagdan	0.2	0.2	0	0.13
Shirak	0.19	0.19	0	1.66	Tsoghamarg	0.18	0.17	0.01	3.73	Yegheg	0.18	0.2	-0.02	-10.7
Shirakamut	0.18	0.17	0.01	2.9	Tsovagyugh	0.2	0.2	0	-0.31	Yeghegis	0.22	0.2	0.02	10.55
Shirakavan	0.21	0.2	0	1.7	Tsovak	0.21	0.19	0.02	8.36	Yeghegnadzor	0.2	0.2	0.01	3.11
Shishkert	0.12	0.15	-0.04	-23.41	Tsovasar	0.19	0.19	0	0.35	Yeghegnavan	0.23	0.23	-0.01	-3.08
Shnogh	0.19	0.16	0.04	23.43	Tsovazard	0.2	0.19	0	1.33	Yeghegnut	0.2	0.2	0	2.07
Shoghakat	0.19	0.18	0.01	3.58	Tsovinar	0.19	0.18	0.01	4.17	Yeghegnut	0.23	0.23	0	0.24
Shoghakn	0.2	0.19	0	1.66	Ttujur	0.2	0.19	0	0.99	Yeghipatrush	0.19	0.19	0	-1.07
Shogheravan	0.09	0.1	-0.01	-9.41	Ttujur	0.18	0.17	0.01	5.04	Yeghnajur	0.1	0.12	-0.03	-20.97
Shramsk	0.09	0.09	0	0	Tufashen	0.2	0.2	0	0.61	Yeghnik	0.18	0.17	0.01	3.52
Shrvenants	0.19	0.19	0	-0.44	Tumanyan	0.22	0.18	0.04	23.41	Yeghvard	0.2	0.2	0.01	2.59
Shurnukh	0.2	0.17	0.04	21.05	Ughedzor	0.14	0.11	0.03	24.3	Yeghvard	0.22	0.21	0	1.07
Shvanidzor	0.15	0.16	-0.01	-6.83	Ujan	0.19	0.22	-0.03	-11.77	Yelpin	0.2	0.19	0.01	2.8
Sipan	0.18	0.18	0	-1.44	Ujanis	0.26	0.25	0.01	3.82	Yenokavan	0.21	0.21	0	1.74
Sipanik	0.21	0.21	0	0.23	Urasar	0.19	0.18	0	1.74	Yeranos	0.18	0.18	0	1.93
Sis	0.21	0.21	0	1.33	Urtsadzor	0.2	0.2	0	1.51	Yeraskh	0.18	0.21	-0.03	-12.94
Sisavan	0.22	0.23	-0.01	-3.45	Urtsalanj	0.17	0.18	0	-0.85	Yeraskhahun	0.23	0.25	-0.01	-5.4
Sisian	0.18	0.18	0.01	3.17	Urtsashen	0.09	0.09	0	0	Yerazgavors	0.2	0.19	0.01	3.63
Sizavet	0.18	0.17	0.01	2.91	Urut	0.2	0.2	0	-0.34	Yerevan	0.18	0.19	-0.01	-3.1
Small Glan	0.09	0.09	0	0	Ushi	0.15	0.15	0.01	4.71	Yerizak	0.09	0.09	0	0
Smithavan	0.18	0.13	0.05	39.34	Uyts	0.18	0.2	-0.01	-5.69	Yernjatap	0.19	0.19	0	0.3
Solak	0.18	0.18	0.01	3.19	Vagharshapat	0.29	0.3	-0.01	-3.67	Yervandashat	0.24	0.27	-0.03	-10.73
Sorik	0.14	0.16	-0.02	-10.2	Vaghashen	0.2	0.2	0	-0.21	Zangakatun	0.2	0.2	0	1.31
Sotk	0.18	0.18	0	-0.4	Vaghatin	0.19	0.18	0.01	4.59	Zar	0.19	0.19	0	0.36
Spandaryan	0.18	0.18	0.01	2.82	Vaghatat	0.2	0.16	0.04	27.02	Zarinja	0.2	0.2	0	1.02
Spitak	0.16	0.15	0.01	6.67	Vahagnadzor	0.22	0.21	0	2.25	Zarishat	0.16	0.15	0	1.47
Srashen	0.2	0.3	-0.09	-31.76	Vahagni	0.2	0.2	0.01	4.19	Zaritat	0.24	0.24	0	0.08
Stepanavan	0.23	0.2	0.02	10.37	Vahan	0.2	0.19	0.01	5.57	Zariver	0.15	0.16	0	-2.26
Surenavan	0.22	0.23	-0.01	-5.63	Vahramaberd	0.18	0.17	0.01	3.11	Zartokn	0.23	0.24	-0.01	-3.79
Suser	0.2	0.2	0	-0.09	Vahravar	0.13	0.22	-0.09	-41.97	Zedea	0.2	0.19	0	1.44
Svarants	0.16	0.16	0.01	4.47	Vanadzor	0.21	0.2	0	1.77	Zolaqar	0.19	0.19	0	1.92
Sverdlov	0.2	0.18	0.02	9.67	Vanadzor	0.21	0.21	0	1.3	Zorak	0.21	0.22	0	-0.85
Syunik	0.22	0.2	0.02	10.28	Vanand	0.16	0.16	0	1.69	Zorakan	0.19	0.18	0.01	4.45
Sznak	0.15	0.15	0.01	4.01	Vanand	0.13	0.12	0.01	5.77	Zorakert	0.15	0.16	-0.01	-6.06
Tairov	0.21	0.22	0	-2.12	Vanashen	0.23	0.24	0	-1.47	Zoravan	0.19	0.19	0.01	3.36
Talin	0.17	0.17	0	-0.99	Vanek	0.24	0.28	-0.04	-15.3	Zovaber	0.19	0.19	0	1.17
Talvorik	0.16	0.19	-0.03	-16.1	Vanevan	0.2	0.19	0	1.86	Zovasar	0.18	0.18	0.01	4.77
Tanahat	0.09	0.09	0	0	Vank	0.17	0.14	0.03	24.95	Zovashen	0.2	0.2	0	-0.57
Tandzatap	0.16	0.18	-0.02	-9.3	Vardablur	0.19	0.18	0	2.34	Zovk	0.2	0.19	0.01	2.58
Tandzaver	0.19	0.18	0	2.64	Vardablur	0.22	0.21	0.01	3.04	Zovuni	0.21	0.23	-0.02	-10.68
Tandzut	0.24	0.25	-0.01	-4.38	Vardadzor	0.19	0.19	0	1.18	Zuygakhbyur	0.18	0.18	0	0.81
Taperakan	0.22	0.22	-0.01	-2.96	Vardaghbyur	0.16	0.16	0	1.84					
Taratumb	0.25	0.24	0.02	6.28	Vardahovit	0.17	0.15	0.01	8.68					
Taronik	0.22	0.24	-0.02	-7.96	Vardanashen	0.24	0.24	0	-1.65					
Tashir	0.17	0.16	0.01	4.61	Vardandzor	0.19	0.2	0	-2.05					
Tashtun	0.21	0.21	0	1.27	Vardaqaar	0.17	0.16	0.01	3.6					
Tasik	0.2	0.2	0	0.14	Vardashat	0.18	0.17	0	2.52					
Tatev	0.22	0.21	0.01	3.86	Vardashen	0.21	0.21	0	-0.18					
Tatul	0.18	0.18	0	-1.95	Vardavan	0.09	0.08	0	5.66					
Tavrus	0.27	0.23	0.04	19.42	Vardavank	0.14	0.19	-0.05	-25.67					
Tavshut	0.17	0.18	-0.01	-3.11	Vardenik	0.19	0.19	0	1.64					
Tavush	0.2	0.2	0	0.88	Vardenis	0.17	0.17	0	-0.96					
Tegh	0.22	0.22	0	0.17	Vardenis	0.19	0.18	0.01	4.73					
Teghenik	0.19	0.19	0	1.54	Vardenut	0.18	0.18	0	-1.24					
Tegher	0.18	0.16	0.02	14.17	Varser	0.19	0.19	0	1.55					
Teghout	0.2	0.18	0.02	13.01	Vayk	0.19	0.18	0.01	6.08					
Teghut	0.27	0.26	0.01	4.03	Vayk	0.22	0.21	0.01	7.14					
Tigranashen	0.13	0.13	0	1.32	Vazashen	0.23	0.2	0.03	16.19					
Tkhkut	0.13	0.16	-0.03	-20.02	Vedi	0.22	0.23	0	-1.92					
Tlik	0.17	0.18	-0.01	-6.64	Vedi	0.28	0.29	0	-1.22					
Tolors	0.21	0.2	0	1.18	Verin Akhtala	0.13	0.12	0	4.08					
Torfavan	0.2	0.2	0.01	2.54	Verin Artashat	0.22	0.23	-0.01	-4.08					
Torosgyugh	0.18	0.18	0	1.58	Verin Bazmaberd	0.19	0.19	0	-0.47					

Settlements in ascending order of changes in CC (2023-2017, %)											
Kapuyt	-60.77	Tsav	-7.01	Kornidzor	-4.06	Byureghavan	-1.66	Tsovagyugh	-0.31	Tretuq	0.05
Gudemnis	-48.41	Arshaluys	-6.99	Avshar	-4.03	Vardanashen	-1.65	Burma	-0.29	Khndzorut	0.06
Vahravar	-41.97	Aralez	-6.97	Nor Armavir	-4.03	Balak	-1.62	Karmirgyugh	-0.28	Drakhtik	0.07
Khor Virap	-40.1	Abovyan	-6.92	Sardarapat	-4.02	Ararat (village)	-1.6	Kutakan	-0.26	Gharibjanyan	0.07
Srashen	-31.76	Metsadzor	-6.86	Aygevan	-3.98	Karmraqa	-1.57	Nor Hachin	-0.24	Hovtashat	0.07
Koghavan	-27.59	Shvanidzor	-6.83	Miljnaton	-3.96	Lermontovo	-1.55	Khachpar	-0.24	Arajador	0.07
Vardavank	-25.67	Nizami	-6.77	Aygeshat	-3.9	Sevaberd	-1.54	Balahovit	-0.23	Zaritap	0.08
Mets Ayridja	-23.66	Nor Yedesia	-6.75	Berkanush	-3.84	Mozrov	-1.52	Tsater	-0.22	Haykadzor	0.09
Shishkert	-23.41	Tsakhkadzor	-6.74	Davtashen	-3.84	Artashat	-1.47	Sarakap	-0.21	Lichk	0.1
Arevis	-23.12	Doghs	-6.74	Zartonk	-3.79	Vanashen	-1.47	Vaghashen	-0.21	Dzoraglukh	0.12
Andokavan	-22.58	Arevshat	-6.73	Bashgyugh	-3.77	Sipan	-1.44	Karadzor	-0.21	Yagdan	0.13
Karadzi	-22.48	Tlik	-6.64	Sarigvyugh	-3.76	Artavaz	-1.44	Tsaghkavan	-0.18	Dzithankov	0.13
Yeghnajur	-20.97	Norakert	-6.58	Krashen	-3.76	Kajaran	-1.42	Vardashen	-0.18	Aghavnadzor	0.13
Tkhkut	-20.02	Margara	-6.47	Ashtarak	-3.75	Jajur	-1.4	Mets Sepasar	-0.18	Agarak	0.14
Mayisyan	-19.69	Gai	-6.45	Vagharshapat	-3.67	Chiva	-1.4	Proshyan	-0.15	Tasik	0.14
Hnaberd	-19.57	Artimet	-6.43	Kobayr	-3.65	Aragats	-1.39	Marts	-0.15	Hovtashen	0.15
Semyonovka	-18.99	Aknalitch	-6.42	Aknashen	-3.63	Sarnaghbyur	-1.39	Hnaberd	-0.14	Chknagh	0.15
Montevan	-18.41	Byuravan	-6.33	Azatavan	-3.62	Ditavan	-1.38	Bavra	-0.12	Melikgyugh	0.16
Shikahogh	-17.37	Karmir Aghek	-6.28	Narek	-3.59	Norashen	-1.35	Lanjik	-0.12	Ashotavan	0.16
Ditsmayri	-16.68	Argavand	-6.25	Aghavnadzor	-3.55	Hatsashen	-1.31	Lchavan	-0.11	Tegh	0.17
Nor Kyurin	-16.27	Apaga	-6.2	Mrganush	-3.54	Nor Yerznka	-1.29	Argina	-0.1	Getk	0.18
Talvorik	-16.1	Aghin	-6.16	Haytagh	-3.5	Ditak	-1.27	Koghes	-0.1	Hayrenyats	0.18
Hako	-15.75	Aratashen	-6.12	Lernamerdz	-3.47	Vardenut	-1.24	Charchakis	-0.09	Kaps	0.18
Verin Shorzha	-15.7	Lenugh	-6.07	Sisavan	-3.45	Vedi	-1.22	Suser	-0.09	Katnaghbyur	0.2
Aravus	-15.35	Zorakert	-6.06	Vosketap	-3.44	Tsaghkasar	-1.2	Masis	-0.08	Kajarants	0.2
Vanek	-15.3	Lusarat	-6.02	Baghramyan	-3.42	Karaberd	-1.19	Sadunts	-0.07	Sipanik	0.23
Alvank	-14.83	Lanjazat	-6.02	Dasht	-3.42	Berdavan	-1.13	Meghrashat	-0.05	Yeghgnut	0.24
Araks	-14.76	Aygek	-6.01	Kaghtsrashen	-3.41	Marmarashen	-1.13	Dsegh	-0.05	Karmrashen	0.24
Erkenants	-14.71	Darik	-5.89	Dimitrov	-3.4	Saralanj	-1.12	Ashnak	-0.04	Gyumri	0.24
Metsamor	-14.56	Gnishik	-5.89	Lernadzor	-3.38	Jamshlu	-1.12	Pokr Sepasar	-0.03	Hovtashen	0.24
Artabuyuk	-14.33	Amoj	-5.87	Garnarich	-3.34	Jraber	-1.11	Dalar	-0.02	Shahumyan	0.25
Khdrants	-14.32	Jrarat	-5.86	Berdik	-3.33	Aghberk	-1.08	Pokrashen	-0.01	Hatsikavan	0.25
Arevashat	-14.22	Nshavan	-5.85	Masis	-3.27	Yeghipatrush	-1.07	Lanjar	0	Marmashen	0.25
Kavtchut	-14.05	Chkalovka	-5.77	Nalbandyan	-3.23	Norashenik	-1.07	Mets Masrik	0	Kakhakn	0.26
Agarak	-14.04	Uyts	-5.69	Arevik	-3.16	Hankavan	-1.05	Abkes	0	Lernantsq	0.27
Chapni	-14.03	Gribovedov	-5.66	Bambakashat	-3.15	Shgharshik	-1.02	Ajabaj	0	Dzorakap	0.29
Sevazhayr	-13.91	Sayat Nova	-5.65	Chermakavan	-3.12	Berkaber	-0.99	Akhta	0	Basen	0.29
Aghavnnavank	-13.82	Bergashat	-5.64	Tavshut	-3.11	Talin	-0.99	Amaghu	0	Yernjatap	0.3
Bagaran	-13.76	Surenavan	-5.63	Yerevan	-3.1	Sasunik	-0.97	Antaravan	0	Geghavan	0.3
Yeraskh	-12.94	Dzoravank	-5.61	Shenik	-3.1	Vardenis	-0.96	Arates	0	Geghadir	0.32
Kanakeravan	-12.75	Hovtamej	-5.6	Yeghegnavan	-3.08	Ayntap	-0.96	Bargushat	0	Noyemberyan	0.32
Jrarbi	-12.41	Berd	-5.59	Getap	-3.06	Lernut	-0.95	Batikyan	0	Karmrashen	0.32
Haykashen	-12.26	Azatashen	-5.59	Jermuk	-3.05	Arevut	-0.93	Byurashat	0	Tsaghkashen	0.32
Ujan	-11.77	Burastan	-5.58	Jrarat	-3.02	Fioletovo	-0.87	Changli	0	Shaghap	0.34
Shahumyan	-11.77	Salli	-5.56	Arazap	-2.96	Zorak	-0.85	Gandzak	0	Arevashogh	0.35
Nor Ughi	-11.76	Noravan	-5.5	Taperakan	-2.96	Urtsalanj	-0.85	Geghatap	0	Tsovasar	0.35
Shagik	-11.76	Aragatsotn	-5.47	Haykavan	-2.95	Gegharkunik	-0.85	Geghavan	0	Areni	0.35
Aygedzor	-11.4	Yeraskhahun	-5.4	Nor Artamet	-2.95	Hushakert	-0.83	Getapnya	0	Antarut	0.35
Geghakert	-11.27	Geghanush	-5.36	Merdzavan	-2.87	Kosh	-0.82	Gokhth	0	Meghradzor	0.36
Nerqin Hand	-11.18	Mrgavan	-5.34	Rind	-2.71	Kanachut	-0.81	Gomarants	0	Zar	0.36
Dprevank	-11.14	Artashar	-5.23	Arbat	-2.68	Berkarat	-0.78	Gushar	0	Gyumri	0.36
Dashtakar	-11.08	Aygvagan	-5.23	Atchanaan	-2.55	Bagratashen	-0.72	Horadis	0	Gandzak	0.38
Lusagyugh	-11.05	Aygeshat	-5.21	Jrashen	-2.51	Shamut	-0.71	Horbategh	0	Maralik	0.39
Kakavasars	-11.03	Azatek	-5.19	Jrashen	-2.48	Brnakot	-0.7	Jamatun	0	Getazat	0.39
Norabats	-11.03	Armavir	-5.08	Khanjyan	-2.47	Alagyaz	-0.67	Kard	0	Pokr Masrik	0.4
Yervandashat	-10.73	Kuris	-5.08	Shahumian	-2.41	Darpas	-0.65	Karut	0	Haykavan	0.41
Yegheg	-10.7	Mrgastan	-4.97	Noyakert	-2.35	Norabak	-0.63	Kashuni	0	Jrap	0.41
Zovuni	-10.68	Aygestan	-4.94	Boloraberd	-2.32	Gogaran	-0.63	Khachik	0	Karchaghbyur	0.43
Aghavnatur	-10.64	Dzagikavan	-4.89	Zariver	-2.26	Khoznavar	-0.61	Khandakhach	0	Aragats	0.45
Bendik	-10.62	Ghukasavan	-4.87	Nerqin Shorja	-2.25	David Bek	-0.58	Khnusik	0	Noraduz	0.46
Amberd	-10.58	Othevan	-4.85	Armash	-2.23	Hobardzi	-0.58	Khordzor	0	Geghhovit	0.46
Sorik	-10.2	Getashen	-4.85	Araqs	-2.18	Zovashen	-0.57	Khosrov	0	Ranchpar	0.48
Arzni	-9.98	Karaglukh	-4.84	Ginevet	-2.17	Voskevaz	-0.55	Kitsk	0	Shenavan	0.48
Hermon	-9.84	Baghramyan	-4.75	Janfida	-2.16	Dzorashen	-0.53	Kochaqar	0	Hatsavan	0.48
Shogheravan	-9.41	Darakert	-4.71	Arpi	-2.16	Chinarin	-0.51	Kordon	0	Shatjrek	0.5
Nzhdeh	-9.33	Norapat	-4.69	Jujevan	-2.15	Chinchin	-0.5	Malev	0	Goris	0.51
Shenavan	-9.31	Pshatavan	-4.56	Tairov	-2.12	Haykasar	-0.5	Nerkin Giratagh	0	Shenavan	0.51
Voskehat	-9.3	Darbnik	-4.56	Kamkhut	-2.11	Shatvan	-0.49	Nerkin Khndzoresk	0	Geghanist	0.51
Tandzatap	-9.3	Arinj	-4.54	Vardandidzor	-2.05	Keti	-0.48	Nigatun	0	Tsaghkavit	0.53
Nor Kyank	-9.24	Nor Amanos	-4.53	Dvin	-2.05	Mets Parni	-0.47	Nrnadzor	0	Ardvi	0.54
Katchatchkut	-8.98	Metsamor	-4.48	Tatul	-1.95	Verin Bazmaberd	-0.47	Qajashen	0	Kamo	0.54
Geghi	-8.55	Karin	-4.46	Karchevan	-1.92	Salut	-0.47	Rind	0	Akhurik	0.54
Mkhchyan	-8.24	Noramarg	-4.4	Vedi	-1.92	Mayisyan	-0.47	Sachanlu	0	Pyunik	0.57
Musaler	-8	Hatsik	-4.39	Aghitu	-1.89	Shrvnents	-0.44	Shramsk	0	Sers	0.57
Mrgavet	-8	Nor Artagers	-4.38	Kabakhlut	-1.87	Hagvi	-0.43	Small Glan	0	Agarakadzor	0.59
Nor Kesaria	-8	Tandzut	-4.38	Mrgashat	-1.87	Sotk	-0.4	Tanahat	0	Salvador	0.59
Taronik	-7.96	Darbas	-4.36	Myasnikyan	-1.8	Nahapetavan	-0.39	Tsakhkasar	0	Lchap	0.6
Khoronk	-7.89	Tsaghkunk	-4.35	Norakert	-1.76	Hartashen	-0.39	Tsakhkots	0	Hayravanq	0.6
Koti	-7.77	Alashkert	-4.33	Kanch	-1.73	Tsatsan	-0.38	Tsghuni	0	Tsilkar	0.6
Mrgashen	-7.75	Vostan	-4.32	Ddmasar	-1.72	Geghard	-0.35	Urtsashen	0	Tufashen	0.61
Amasia	-7.69	Dovegh	-4.24	Armavir	-1.69	Garnahovit	-0.34	Verin Giratagh	0	Lor	0.61
Agarak	-7.4	Araqsavan	-4.22	Aygezard	-1.68	Urut	-0.34	Vocheti	0	Nor Khachakap	0.62
Jrahovit	-7.34	Aragatsavan	-4.16	Pokr Vedi	-1.68	Krasar	-0.33	Yerizak	0	Geghadzor	0.66
Chapkut	-7.21	Verin Dvin	-4.1	Daranak	-1.68	Dashtavan	-0.31	Geghamavan	0.02	Artsvanik	0.67
Nor Kharberd	-7.18	Verin Artashat	-4.08	Deghdzut	-1.68	Geghamabak	-0.31	Hovuni	0.04	Lernakert	0.67

Kapan	0.7	Zeeda	1.44	Verin Getashen	2.22	Voghjaberd	3.4	Berdashen	5.12	Yeghegis	10.55
-------	-----	-------	------	----------------	------	------------	-----	-----------	------	----------	-------

Lusakunq	0.71	Alapars	1.45	Vahagnadzor	2.25	Berdkunk	3.4	Getap	5.15	Horbategh	10.72
Hatsik	0.73	Buzhakan	1.45	Verin Ptghni	2.29	Jajuravan	3.42	Aregnadem	5.21	Dprabak	10.89
Tsapatagh	0.73	Noravan	1.46	Khashtarak	2.29	Arteni	3.42	Kasakh	5.21	Karaberd	10.94
Tsaghkut	0.74	Nor Akhuryan	1.46	Vardablur	2.34	Agarak	3.48	Marmarik	5.26	Okhtar	11.07
Akhuryan	0.75	Zarishat	1.47	Ishkhanasar	2.35	Karnut	3.5	Choratan	5.33	Ltsen	11.17
Getatagh	0.75	Gndevaz	1.47	Kurtan	2.36	Hovtun	3.51	Nerkin Getashen	5.43	Gandzaqar	11.33
Jil	0.75	Aragyugh	1.48	Verin Sasunik	2.39	Katnajur	3.51	Kharkov	5.49	Aknaghbyur	11.49
Karashen	0.77	Nerkin Sasnashen	1.51	Khnkoyan	2.41	Agarakavan	3.51	Sarapat	5.5	Lusakn	11.72
Kapan	0.77	Urtsadzor	1.51	Kuchak	2.42	Artavan	3.52	Kaniashir	5.52	Katnaghbyur	11.76
Nigavan	0.77	Dastakert	1.52	Avazan	2.42	Yeghnik	3.52	Vahan	5.57	Antaramej	11.77
Saralanj	0.78	Lehvaz	1.53	Kamaris	2.44	Hartavan	3.54	Dzoramat	5.62	Barepat	11.94
Vernashen	0.78	Goravan	1.53	Khot	2.46	Getahovit	3.55	Vardavan	5.66	Lchkadzor	12.14
Kakavadzor	0.78	Teghenik	1.54	Shenkani	2.49	Shoghakat	3.58	Saratovka	5.68	Dzyunashogh	12.19
Khachaghbyur	0.79	Varser	1.55	Akhatyan	2.5	Orgov	3.59	Gavar	5.75	Lernahovit	12.21
Shenatagh	0.79	Lusaghbyur	1.56	Avshen	2.51	Vardaqaqar	3.6	Irind	5.76	Barekamavan	12.23
Shaghat	0.79	Karashamb	1.56	Norashen	2.52	Yerazgavors	3.63	Vanand	5.77	Getavan	12.32
Kaghnut	0.8	Torosgyugh	1.58	Vardashat	2.52	Meghri	3.64	Abovyan	5.81	Dzorastan	12.41
Zuygakhbyur	0.81	Alvar	1.58	Torfavan	2.54	Hartashen	3.67	Akori	5.82	Vorotan	12.49
Kirants	0.83	Ptghavan	1.59	Hrazdan	2.55	Tsoghamarg	3.73	Amasia	5.88	Bazum	12.57
Agehovit	0.85	Saghmosavan	1.59	Gagarin	2.56	Mughni	3.77	Katnarat	5.92	Ijevanatun	12.82
Tavush	0.88	Geghanist	1.59	Zovk	2.58	Azat	3.79	Arin	5.97	Chambarak	12.93
Shamiram	0.89	Astghadzor	1.61	Yeghvard	2.59	Aramus	3.82	Vayk	6.08	Teghout	13.01
Jrarat	0.91	Tsaghkalanj	1.62	Halidzor	2.6	Lernanist	3.82	Voskepar	6.11	Bardzrashen	13.08
Areguni	0.92	Saratak	1.63	Jiliza	2.61	Saranist	3.82	Antarashat	6.17	Gomk	13.21
Martuni	0.94	Beniamin	1.63	Geghadir	2.62	Martiros	3.82	Sevakar	6.18	Ohanavan	13.26
Bardzrashen	0.95	Vardenik	1.64	Artanish	2.62	Ujanis	3.82	Sarnakunk	6.23	Kruglaja Shishka	13.3
Kathnarat	0.95	Argel	1.64	Tandzaver	2.64	Artamet	3.83	Dzoraghbyur	6.24	Nor Aznaberd	13.34
Ttujur	0.99	Shoghakn	1.66	Ayrk	2.64	Arzakan	3.85	Khachardzan	6.24	Herher	13.35
Isahakyan	0.99	Shirak	1.66	Sevan	2.69	Tatev	3.86	Saghgyugh	6.27	Araksashen	13.36
Nor Geghi	1	Akunk	1.66	Nurnus	2.7	Oshakan	3.86	Taratumb	6.28	Pokr Ayrum	13.44
Lichk	1.01	Arapi	1.68	Fantan	2.7	Aralanj	3.88	Arayi	6.35	Lusahovit	13.65
Zarinja	1.02	Vanand	1.69	Kaghsi	2.72	Lernavan	3.9	Getamej	6.38	Tegher	14.17
Lanjaghbyur	1.04	Hayanist	1.7	Jrashen	2.73	Hartagyugh	3.92	Dzoraget	6.39	Nerkin Khotanan	14.27
Tsakhkaber	1.05	Geghamasar	1.7	Aghtsq	2.73	Sznak	4.01	Vosketas	6.45	Nor Astghaberd	14.43
Akner	1.06	Shirakavan	1.7	Goghtanik	2.75	Bazmaghbyur	4.01	Khnatsakh	6.48	Kechut	14.61
Getik	1.06	Akunk	1.7	Karenis	2.78	Parakar	4.03	Parpi	6.5	Navur	14.61
Geghashen	1.06	Horom	1.71	Yelpin	2.8	Teghut	4.03	Azatamat	6.62	Gosh	14.62
Yeghvard	1.07	Pambak	1.71	Saralanj	2.81	Verin Akhtala	4.08	Torunik	6.65	Megvahovit	15.43
Geghasar	1.08	Goghovit	1.71	Blagodarnoe	2.81	Byurakn	4.08	Spitak	6.67	Alaverdi	15.59
Hatsavan	1.08	Byurakan	1.71	Shinuhayr	2.81	Ararat	4.11	Tsghuk	6.7	Arjhovit	15.87
Mgart	1.09	Paghakn	1.74	Ptghunk	2.82	Aniavan	4.15	Artashavan	6.72	Vazashen	16.19
Lusashogh	1.1	Urasar	1.74	Nerkin Bazmaberd	2.82	Bagravan	4.16	Getargel	6.74	Hors	16.22
Dashtadem	1.1	Yenokavan	1.74	Spandaryan	2.82	Tsovinar	4.17	Aghvorik	6.8	Lernagog	16.86
Tsamakasar	1.1	Ferik	1.75	Ghazanchi	2.83	Vahagni	4.19	Pukhrut	6.97	Hovk	17.03
Rya Taza	1.12	Anipemza	1.76	Chakaten	2.84	Arpeni	4.19	Jaghatsadzor	6.98	Geghakar	17.27
Lukashin	1.12	Lernapat	1.77	Hrazdan	2.85	Kotayq	4.26	Karahunj	7.02	Antaramut	17.29
Lchashen	1.13	Vanadzor	1.77	Archis	2.85	Medovka	4.28	Vayk	7.14	Saravan	17.66
Armanis	1.13	Arevadasht	1.79	Kaputan	2.86	Charentsavan	4.3	Martuni	7.15	Ahnidzor	17.85
Akner	1.14	Madina	1.8	Metsamoravan	2.86	Bnunis	4.33	Ijevan	7.16	Chkalov	18.09
Harich	1.14	Gegharot	1.8	Artik	2.88	Arevabuyr	4.33	Nshkharq	7.17	Mikheylovka	18.27
Karbi	1.14	Chochkan	1.81	Aghnjadzor	2.89	Nor Gyugh	4.39	Ghazaravan	7.2	Kayan	19.12
Saragyugh	1.15	Malishka	1.81	Shirakamut	2.9	Aparan	4.42	Shatin	7.3	Karakorum	19.16
Zovaber	1.17	Bardzruni	1.83	Sizavet	2.91	Zorakan	4.45	Mayakovski	7.31	Verin Khotanan	19.37
Tolors	1.18	Azatan	1.84	Gladzor	2.94	Jradzor	4.47	Lernagyugh	7.44	Tavrus	19.42
Arevik	1.18	Vardaghbyur	1.84	Akhpradzor	2.96	Svarants	4.47	Aznvadzor	7.79	Petrovka	19.89
Vardadzor	1.18	Sarnaghbyur	1.85	Pemzashen	2.97	Karinj	4.48	Dilijan	7.94	Shurnukh	21.05
Khndzoresk	1.19	Dzoragyugh	1.85	Avan	2.97	Haghartsin	4.5	Antarashen	8.14	Noramut	21.65
Garni	1.2	Vanevan	1.86	Sarahart	3	Dalarik	4.51	Tsovak	8.36	Itsaqar	21.75
Artsvanist	1.2	Tsakkar	1.88	Kut	3.01	Debet	4.55	Acharkut	8.46	Tumanyan	23.41
Babikavan	1.2	Apnagayugh	1.89	Lernakert	3.02	Vaghatin	4.59	Margahovit	8.5	Shnogh	23.43
Sarukhan	1.2	Bjni	1.9	Vardablur	3.04	Privolnoye	4.59	Lanjanist	8.53	Ughedzor	24.3
Paghakan	1.24	Pambak	1.91	Gugark	3.04	Voskevan	4.61	Paruyr Sevak	8.57	Haghpat	24.72
Mets Ayrum	1.24	Zolaqar	1.92	Pushkino	3.06	Tashir	4.61	Bardzravan	8.59	Karkop	24.77
Metsavan	1.25	Aruch	1.93	Dzoragyugh	3.11	Abovyan	4.64	Atan	8.68	Vank	24.95
Tashtun	1.27	Yeranos	1.93	Yeghegnadzor	3.11	Ardenis	4.66	Vardahovit	8.68	Amrakits	25.76
Gyulagarak	1.28	Odzun	1.94	Vahramaberd	3.11	Gtashen	4.71	Paghaghbyur	9.13	Baghrmryan	25.99
Vanadzor	1.3	Gorgoch	1.95	Lusadzor	3.14	Ushi	4.71	Kathnakhpyur	9.17	Vaghatur	27.02
Nor Artik	1.31	Voskehask	1.96	Kayq	3.16	Vardenis	4.73	Ptghni	9.31	Partizak	28.49
Zangakatun	1.31	Arjut	1.96	Achajur	3.16	Lusaghbyur	4.74	Shamlugh	9.4	Kalavan	29.06
Tigranashen	1.32	Lusagyugh	1.97	Sisian	3.17	Zovasar	4.77	Voskehat	9.47	Apaven	30.53
Sis	1.33	Arpunk	1.98	Tsaghkashen	3.17	Musavylyan	4.81	Artsni	9.56	Gogavan	32.54
Tsovazard	1.33	Shamb	1.98	Solak	3.19	Bayandur	4.86	Sverdlov	9.67	Dashtadem	35.18
Lusakert	1.34	Lorut	2.02	Verishen	3.2	Karakert	4.89	Mets Sarian	9.79	Getishen	36.79
Hoghmiik	1.35	Lernapar	2.04	Debetavan	3.2	Lejan	4.92	Lernajur	9.97	Hovnadzor	37.62
Karmravan	1.36	Hovit	2.04	Ddmashen	3.24	Koghb	4.95	Por	10.07	Vorotan	38.07
Poqr Sarian	1.38	Yeghegnut	2.07	Dian	3.27	Shahumyan	4.95	Jrvej	10.13	Smithavan	39.34
Sarchapet	1.38	Mastara	2.07	Makenis	3.29	Gorayk	4.97	Baghanis	10.27	Mirak	41.56
Voghji	1.38	Norashen	2.09	Gargar	3.29	Gusanagyugh	4.98	Aygut	10.28	Gomaran	56.17
Lusadzor	1.39	Saramej	2.1	Ashotsk	3.31	Tsaghkunk	4.98	Syunik	10.28	Bovadzor	59.71
Hatis	1.4	Mutsk	2.1	Haghtanak	3.33	Ttujur	5.04	Tsakhkashat	10.29	Kopoy Var	65.21
Shaqi	1.4	Lernarot	2.11	Saralanj	3.34	Khachashen	5.04	Stepanavan	10.37		
Sevkar	1.41	Verin Sasnashen	2.15	Zoravan	3.36	Khachik	5.07	Dzoragyugh	10.43		
Angeghakot	1.43	Novoseltsovo	2.18	Aygabats	3.38	Goght	5.1	Lori Berd	10.44		
Nor Kyang	1.43	Garni	2.21	Bandivan	3.38	Akunk	5.11	Jrambar	10.54		

Appendix 3.1.H-1. Area of pollinator habitats across marzes

	Aragats -otn	Ararat	Arma- vir	Geghar- kunik	Kotayk	Lori	Shirak	Syunik	Tavush	Vayots Dzor
Based on the Esri 2023 land cover dataset										
Alpine meadows (no trees)	20208.6	2278.8	0.1	40568.0	10166.8	6225.2	10665.6	50190.9	350.5	19487.7
Broadleaf woodland (no trees)	23.9	731.3	12.1	1005.1	401.0	3847.4	13.7	14793.8	42039.5	444.3
Desert (no trees)	26.9	686.6	0.4	139.6	29.1	58.3	37.1	289.6	57.6	66.9
Grasslands in forest zone	3595.4	17260.7	18.5	22349.1	26959.7	48634.6	19.3	87048.4	50396.4	24243.0
Juniper (no trees)	48.6	42.9	1.7	2123.9	38.0	88.4	16.0	1397.2	293.2	9799.8
Marsh (no trees)	599.0	4344.4	681.5	10138.3	919.0	3156.0	2831.1	954.2	33.7	290.2
Meadow-steppe (no trees)	47306.2	2792.6	9.6	40462.0	24157.9	63512.0	38712.6	30107.2	1773.9	8488.3
Semidesert (no trees)	72043.4	40915.7	44576.0	400.7	31410.4	175.5	1681.0	11645.1	29.4	36166.2
Steppe (no trees)	50911.2	71558.9	0.9	82765.7	45027.9	35862.5	77091.6	79733.7	2563.5	74636.3
Subalpine (no trees)	10286.0	5244.0	14.4	124400.7	15955.8	83390.0	37360.3	80505.4	21546.6	37564.3
Trees in Alpine meadows	499.3	278.1	372.1	145.5	268.0	270.9	219.3	107.0	7.5	80.6
Trees in Broadleaf woodland	438.2	246.1	104.9	790.4	562.3	4304.9	686.1	2375.1	20062.9	268.5
Trees in Desert	30.4	19.7	6.9	446.4	312.1	521.6	108.9	460.5	367.3	94.8
Trees in Forest zone	1054.9	1171.9	29.5	8761.6	9668.3	67476.4	426.6	41948.8	97583.2	2945.5
Trees in Juniper	982.6	724.2	879.2	874.7	1145.3	797.9	1144.9	923.9	251.0	516.3
Trees in Marsh	110.4	65.7	33.0	430.9	122.4	294.8	306.3	179.4	202.0	76.8
Trees in Meadow-steppe	2497.2	94.1	12.4	877.9	1679.9	2350.0	213.8	177.5	159.9	27.7
Trees in Semidesert	682.9	330.0	429.0	735.4	618.7	730.7	847.4	736.9	231.0	178.4
Trees in Steppe	1318.9	1473.3	102.0	1306.8	413.1	3409.1	671.3	590.1	366.6	196.3
Trees in Subalpine	29.8	134.5	1.6	2570.5	3311.7	7170.0	352.5	4247.3	6379.4	27.5
Croplands (Esri 2023)	42410.2	29289.8	59996.3	39515.1	25762.2	28814.3	71719.9	22068.7	7337.8	3019.8
Built-up (Esri 2023)	13812.2	16046.4	17903.0	19186.3	19412.8	14395.7	14002.8	7085.6	9171.5	4380.6
Water (Esri 2023)	307.6	3042.6	600.5	127372.9	252.4	336.5	2972.1	1434.3	404.8	218.7
Based on the ESA 2021 land cover dataset										
Alpine meadows (no trees)	20224.5	2274.9	0.1	40597.7	10390.1	6230.9	10661.7	50292.3	343.4	19510.0
Broadleaf woodland (no trees)	17.6	727.3	10.4	1623.4	366.9	3092.0	12.7	12033.0	36437.4	419.2
Desert (no trees)	27.5	701.9	0.1	140.9	29.4	57.8	37.4	267.3	49.9	65.9
Grasslands in forest zone	3298.3	15658.2	14.6	22430.7	27258.3	41736.3	19.9	62015.9	43908.6	21087.0
Juniper (no trees)	42.8	53.4	6.0	2112.0	46.0	148.6	17.5	1072.0	915.5	7419.1
Marsh (no trees)	306.2	3881.1	1061.4	10159.1	1002.3	3197.2	3346.1	592.6	36.7	266.2
Meadow-steppe (no trees)	47045.7	2953.4	15.8	41339.5	23849.4	68373.8	45341.7	28615.3	4347.2	8785.8
Semidesert (no trees)	76959.8	42802.5	58595.8	713.9	36365.6	302.8	1407.8	10476.3	176.0	35625.8
Steppe (no trees)	41711.6	66804.7	9.0	86054.1	40266.6	42609.7	76558.5	64909.2	3629.0	70790.4
Subalpine (no trees)	10586.8	5431.7	121.6	125803.0	15665.8	82506.9	39214.5	76899.1	20983.6	37099.7
Trees in Alpine meadows	2701.0	1643.6	2454.5	524.7	1357.2	732.5	637.7	900.7	42.6	524.1
Trees in Broadleaf woodland	2204.6	1404.7	707.5	3064.4	2362.1	6851.5	3242.4	7501.9	26901.5	1526.0
Trees in Desert	395.2	286.3	159.8	1393.7	1137.4	1137.6	236.3	1393.2	596.6	926.0
Trees in Forest zone	2651.7	2992.3	250.7	9933.1	10940.6	75710.6	1139.6	64679.0	102997.0	5674.4
Trees in Juniper	4703.0	3590.8	5113.5	3006.4	4022.5	2100.0	4495.9	3632.5	593.4	2987.3
Trees in Marsh	411.2	349.7	172.0	1336.9	515.7	985.1	1258.3	660.1	1000.8	445.9
Trees in Meadow-steppe	2480.5	682.9	129.1	1493.4	2116.0	3106.9	361.6	746.5	721.3	325.3
Trees in Semidesert	5517.6	3432.2	3428.5	2662.5	4618.2	2048.2	3187.9	3737.8	486.2	2261.7
Trees in Steppe	2833.5	4097.1	794.8	2255.7	1981.6	4887.0	1498.0	3746.7	446.3	1571.2
Trees in Subalpine	478.5	825.4	353.7	2765.5	4290.9	8848.8	348.7	7224.3	7694.4	430.3
Croplands (Esri 2023)	40967.9	28705.0	43556.0	35525.6	24059.4	16977.7	60510.3	34674.8	6510.1	4745.5
Built-up (Esri 2023)	3217.0	6679.0	8428.3	5154.2	5707.4	3871.2	5706.6	1285.7	2429.9	511.1
Water (Esri 2023)	440.5	2916.1	402.0	127148.8	246.1	305.3	2849.7	1700.8	324.8	228.4

Appendix 3.1.H-2. Sites where pollinator surveys were conducted

Vegetation zones	Coordinates of survey sites				
Alpine meadows and carpets	41°03'38.6"N 43°59'54.5"E	40°27'59.2"N 44°11'31.4"E	40°13'55.3"N 45°00'40.2"E	39°07'07.5"N 46°09'10.9"E	
Subalpine meadows	41°03'47.6"N 44°06'40.2"E	40°23'35.9"N 45°01'54.5"E	40°41'22.5"N 44°53'37.8"E	39°57'12.5"N 45°13'53.7"E	39°01'46.1"N 46°21'00.1"E
Meadow-steppe	41°01'03.1"N 43°58'21.5"E	40°47'39.5"N 44°37'06.3"E	40°38'54.1"N 44°30'02.8"E	40°23'42.4"N 45°01'51.0"E	39°00'46.0"N 46°22'28.7"E
Steppe	41°00'14.2"N 43°43'36.4"E	40°52'28.7"N 43°59'49.9"E	40°23'27.2"N 44°26'48.5"E	39°51'54.0"N 44°58'32.3"E	39°29'05.8"N 46°07'56.4"E
Forest	40°43'03.1"N 44°52'12.8"E	40°37'23.7"N 44°27'52.7"E	39°05'22.2"N 46°27'40.8"E	39°05'57.2"N 46°09'37.9"E	

Juniper	39°59'50.5"N 44°54'26.2"E	40°25'24.0"N 45°28'54.0"E	39°55'17.8"N 45°14'28.1"E	38°59'00.4"N 46°11'47.3"E	
Broadleaf woodland	40°00'53.5"N 44°54'55.3"E	41°07'11.4"N 44°39'26.7"E	39°56'17.9"N 45°14'10.5"E	39°42'17.4"N 45°33'48.2"E	38°59'07.7"N 46°22'39.6"E
Semidesert	40°09'20.9"N 43°52'41.4"E	40°02'50.8"N 44°11'44.2"E	39°56'33.9"N 44°44'26.6"E	39°39'55.1"N 45°30'37.4"E	38°54'46.9"N 46°17'22.1"E
Desert	39°53'29.6"N 44°43'47.7"E				
Marsh	41°03'41.3"N 43°43'09.3"E	41°04'06.0"N 44°16'54.8"E	40°38'15.1"N 44°18'24.2"E	40°04'22.5"N 44°05'21.4"E	40°02'30.6"N 45°14'24.2"E

Appendix 3.1.H-3. Identified taxa of key pollinators across vegetation zones

Pollinator species	Alpine vegetation	Subalpine meadows	Meadow-steppe	Steppe	Forest zone	Juniper	Broadleaf woodland	Semi-desert	Desert	Marsh
Hymenoptera (Apoidea)										
<i>Bombus alboluteus</i>	+	+	-	-	-	-	-	-	-	-
<i>B. alpigenuus</i>	+	+	+	-	-	-	-	-	-	-
<i>B. armeniacus</i>	+	+	+	-	-	-	-	-	-	-
<i>B. persicus</i>	-	+	+	+	-	-	-	-	-	-
<i>B. niveatus</i>	+	+	+	-	-	-	-	-	-	-
<i>B. portchinsky</i>	-	-	-	+	-	+	+	-	-	-
<i>B. argillaceus</i>	-	-	+	+	+	-	-	-	-	-
<i>B. pascuorum</i>	-	-	-	+	+	-	+	-	-	-
<i>B. mesomeles</i>	+	+	+	+	-	-	-	-	-	-
<i>B. haematurus</i>	-	-	-	+	+	-	-	-	-	-
<i>B. cf. hortorum</i>	-	-	+	+	+	-	-	-	-	+
<i>Xylocopa valga</i>	-	-	+	+	+	+	+	+	+	-
<i>Xylocopa violacea</i>	-	+	+	+	+	-	+	-	-	-
<i>Xylocopa olivieri</i>	-	-	-	-	-	+	+	-	+	-
<i>Xylocopa cf. armeniaca</i>	+	+	+	-	-	-	-	-	-	-
<i>Trachusa serratae</i>	-	-	-	-	+	-	+	-	-	-
<i>Anthidium cf. florentinum</i>	-	-	-	+	-	+	+	+	+	+
<i>Anthidium cf. cingulatum</i>	-	-	+	+	-	+	+	+	+	-
<i>Rodanthidium superbum</i>	-	-	-	-	-	+	+	+	+	-
<i>Andrena cf. albicans</i>	+	+	+	+	+	-	-	-	-	+
<i>Andrena cf. vetula</i>	-	-	-	+	-	+	-	+	+	-
<i>Melliturga cf. clavicornis</i>	-	-	-	-	-	+	+	+	+	+
<i>Halictus cf. maculatus</i>	-	-	+	+	+	-	+	-	-	+
<i>Halictus morbillosus</i>	-	-	-	+	+	+	-	-	-	+
Subtotal	7	9	13	15	10	9	11	6	7	6
Lepidoptera										
<i>Nomophilla noctuella</i>	+	+	+	-	-	-	-	-	-	-
<i>Chrysoesthia cf. drurela</i>	+	+	+	+	-	-	-	-	-	+
<i>Synaphe cf. moldavica</i>	-	+	+	+	+	-	-	-	-	-
<i>Nemophora cf. fasciella</i>	+	+	+	-	+	-	-	-	-	+
<i>Nemophora cf. reamurella</i>	-	-	+	-	+	-	-	-	-	-
<i>Yponomeuta sp.</i>	-	-	+	+	+	-	+	-	-	-
<i>Acontia trabecalis</i>	-	+	+	+	+	+	-	-	+	+
<i>Acronicta cf. dentiosa</i>	+	+	+	+	-	-	+	-	-	-
<i>Hecatera disodea</i>	+	+	+	-	-	-	-	-	-	-
<i>Schinia imperialis!</i>	+	+	+	-	-	+	+	-	-	-
<i>Amata sp.</i>	-	+	+	+	+	-	+	-	-	-
<i>Ulochlaena cf. hirta</i>	+	+	+	-	-	-	-	-	-	-
<i>Mythimanna cf. vittelina</i>	-	+	+	+	-	-	-	-	-	+
<i>Melanchnra cf. persicaria</i>	-	-	+	+	+	-	-	-	-	-

<i>Heliothis cf. peltigra</i>	-	-	+	+	+	-	-	-	-	+
<i>Catocala puerpera</i>	-	-	-	+	+	+	+	-	-	-
<i>Catocala fraxini</i>	-	-	-	-	+	-	+	-	-	-
<i>Catocala cf. deducta</i>	-	-	-	-	+	-	+	-	-	-
<i>Catocala neonympha</i>	-	-	-	-	-	+	-	+	+	-
<i>Utetheisa pulchella</i>	+	+	+	+	+	+	+	+	+	+
<i>Euplagia quadripunctaria</i>	-	-	-	-	+	-	+	-	-	-
<i>Euplagia splendidior</i>	-	-	-	+	-	+	+	-	-	-
Subtotal	8	12	16	12	13	6	10	2	3	6
Diptera										
<i>Chrysotoxum festivus</i>	+	+	+	-	+	-	-	-	-	+
<i>Erystalis taenax</i>	+	+	+	+	+	+	+	-	-	+
<i>Sphaerophoria sp.</i>	+	+	-	-	-	-	-	-	-	-
<i>Xantogramma cf. citrofasciata</i>	+	+	-	-	-	-	-	-	-	+
<i>Erystalis cf. arbustorum</i>	-	+	+	+	+	-	-	-	-	-
<i>Syrirta cf. pipiens</i>	-	-	-	+	+	+	+	-	-	-
<i>Vollucella inanis</i>	-	-	+	+	+	-	-	-	-	+
<i>Episyrphus balteatus</i>	-	+	+	+	+	-	-	-	-	+
<i>Merodon cf. caucasicus</i>	-	-	+	-	+	-	-	-	-	+
<i>Sphaerophoria cf. scripta</i>	+	+	+	+	-	-	-	-	-	+
<i>Eupeodes corollae</i>	+	+	-	+	+	-	-	-	-	+
<i>Helophillus cf. pendullus</i>	-	-	+	+	+	-	-	-	-	-
<i>Vollucella bombylans</i>	-	-	+	-	+	-	-	-	-	-
<i>Vollucella zonaria</i>	-	-	-	+	+	+	+	-	-	+
<i>Syrphus ribesii</i>	+	+	+	+	+	-	-	-	-	+
<i>Hemipenthes morio</i>	-	-	-	+	-	+	+	+	+	-
<i>Bombylius cf. medius</i>	+	+	+	+	+	+	-	-	-	-
<i>Triplasia cf. pictus</i>	-	+	+	+	-	-	-	-	-	-
<i>Hemipenthes cf. velutina</i>	-	-	+	+	-	-	+	-	-	-
<i>Satyramoeba cf. hetrusa</i>	-	-	-	+	-	+	-	+	+	-
<i>Bombylius cf. major</i>	-	+	+	-	+	-	-	-	-	-
Subtotal	8	12	14	16	14	6	5	2	2	10
Coleoptera										
<i>Podonta elongata</i>	-	-	-	+	-	+	-	+	-	-
<i>Cteniopus elegans</i>	-	-	-	-	-	+	-	-	+	-
<i>Omophlus flavipennis</i>	-	-	+	+	+	+	+	+	-	-
<i>Omophlus cf. caucasicus</i>	-	-	-	+	+	-	-	-	-	-
<i>Eulasia chrysopyga</i>	-	-	+	+	+	-	+	-	-	-
<i>Eulasia korbi</i>	-	-	-	+	-	+	+	-	-	-
<i>Eulasia bombylliformis</i>	-	-	-	+	-	+	-	+	-	-
<i>Glaphyrus micans</i>	-	-	-	-	-	-	-	+	+	-
<i>Glaphyrus armeniacus</i>	-	-	-	-	-	-	-	-	+	-
<i>Pharaonus caucasicus</i>	-	-	-	-	-	-	-	-	+	-
<i>Hoplia pollinosa</i>	-	-	+	-	+	-	-	-	-	-
<i>Mylabris variabilis</i>	-	-	-	+	+	+	+	+	-	-
<i>Mylabris humerosus</i>				+		+		+	+	
<i>Mylabris cincta</i>	-	-	-	+	-	+	+	+	-	-
<i>Mylabris quadripunctata</i>	-	-	+	+	+	-	-	-	-	-
<i>Cerocoma festiva</i>	-	-	-	-	-	-	-	+	+	-
<i>Cerocoma dahli</i>	-	-	-	+	-	+	+	+	+	-
<i>Lydus sp.</i>	-	+	+	+	+	-	-	-	-	-
<i>Oxythyrea funesta</i>	+	+	+	+	+	-	-	-	-	+
<i>Pygopleurus transcaucasicus</i>	-	-	+	+	-	+	+	+	-	-
<i>P. cf. psylotrichius</i>	+	+	+	-	-	-	-	-	-	+
Subtotal	2	3	8	14	8	10	7	10	7	2
Total	25	36	51	57	45	31	33	20	19	24

Appendix 3.1.H-4. Area of croplands potentially visited by pollinators

		Cropland area visited by pollinators, ha						Share of cropland area visited by pollinators, %					
		Score 1	Score 2	Score 3	Score 4	Score 5	Total	Score 1	Score 2	Score 3	Score 4	Score 5	Total
Hymenoptera Esri	Aragatsotn	0	138.84	228.33	172.26	28697.91	29237.34	0	0.32	0.52	0.39	65.7	66.93
	Ararat	0	2376.09	75.5	11.29	17226.14	19689.02	0	7.9	0.25	0.04	57.3	65.49
	Armavir	0	1074.04	32.36	0	30603.6	31710	0	1.76	0.05	0	50.18	51.99
	Gegharkunik	0	1055.91	131.43	2752.94	21003.77	24944.05	0	2.59	0.32	6.74	51.44	61.09
	Kotayk	0	365.44	94.56	2447.72	17842.84	20750.56	0	1.37	0.35	9.15	66.69	77.56
	Lori	0	321.45	789.22	1970.88	18743.43	21824.98	0	1.07	2.64	6.59	62.67	72.97
	Shirak	0	1375.86	230.67	0	41441.86	43048.39	0	1.87	0.31	0	56.31	58.49
	Syunik	0	428.03	121.93	3564	16537.32	20651.28	0	1.85	0.53	15.39	71.4	89.17
	Tavush	0	3.38	0	871.16	5695.77	6570.31	0	0.04	0	11.18	73.07	84.29
	Vayots Dzor	0	0.79	46.87	149.71	2931.67	3129.04	0	0.02	1.46	4.66	91.34	97.48
Armenia*	0	7139.83	1750.87	11939.96	200724.3	221555		2.10	0.51	3.51	59.04	65.17	
Hymenoptera ESA	Aragatsotn	0	280.98	90.28	304.67	46016.53	46692.46	0	0.6	0.2	0.6	98.0	99.4
	Ararat	0	3697.35	1198.16	147.73	27546.83	32590.07	0	11.3	3.7	0.5	84.2	99.6
	Armavir	0	1920.63	1224.20	0.00	45289.51	48434.34	0	4.0	2.5		93.5	100.0
	Gegharkunik	0	737.10	304.13	3810.27	35144.23	39995.73	0	1.8	0.8	9.4	87.0	99.0
	Kotayk	0	191.35	192.47	3089.02	24239.39	27712.23	0	0.7	0.7	11.1	87.5	100.0
	Lori	0	347.86	123.80	1881.33	16939.14	19292.13	0	1.8	0.6	9.7	87.4	99.5
	Shirak	0	1591.40	346.75	0.00	62729.29	64667.44	0	2.4	0.5		94.6	97.5
	Syunik	0	322.04	209.46	3728.15	34379.32	38638.97	0	0.8	0.5	9.6	88.4	99.4
	Tavush	0	36.47	0.00	997.42	7445.62	8479.51	0	0.4		11.8	87.8	100.0
	Vayots Dzor	0	13.56	59.09	298.87	5728.95	6100.47	0	0.2	1.0	4.9	93.9	100.0
Armenia*	0	9138.75	3748.33	14257.46	305458.81	332603.35		2.72	1.12	4.25	91.07	99.16	
Lepidoptera Esri	Aragatsotn	248.19	326.37	9621.66	10941.21	0.04	21137.47	0.57	0.75	22.03	25.05	0.00	48.39
	Ararat	1640.69	6.61	11464.86	124.62	0.00	13236.78	5.46	0.02	38.13	0.41	0.00	44.03
	Armavir	573.33	0.00	19928.52	23.01	0.00	20524.86	0.94	0.00	32.68	0.04	0.00	33.65
	Gegharkunik	427.38	159.45	4462.03	13386.18	325.75	18760.80	1.05	0.39	10.93	32.78	0.80	45.95
	Kotayk	203.92	43.75	9936.62	5243.82	116.46	15544.57	0.76	0.16	37.14	19.60	0.44	58.10
	Lori	229.98	1079.27	2705.51	12102.80	120.15	16237.70	0.77	3.61	9.05	40.47	0.40	54.29
	Shirak	908.09	276.37	1814.88	27235.35	0.00	30234.70	1.23	0.38	2.47	37.01	0.00	41.08
	Syunik	66.19	94.20	2749.94	13055.50	328.15	16293.97	0.29	0.41	11.87	56.37	1.42	70.35
	Tavush	0.00	371.30	292.62	4625.39	4.95	5294.26	0.00	4.76	3.75	59.34	0.06	67.92
	Vayots Dzor	37.74	4.94	1982.03	664.96	1.78	2691.46	1.18	0.15	61.75	20.72	0.06	83.85
Armenia*	4335.52	2362.25	64958.67	87402.85	897.27	159956.56	1.28	0.69	19.11	25.71	0.26	47.05	
Lepidoptera ESA	Aragatsotn	355.31	102.40	12984.53	31996.13	0.77	45439.13	0.76	0.22	27.65	68.13	0.00	96.75
	Ararat	4735.00	3.58	25525.45	1968.01	0.32	32232.36	14.47	0.01	77.98	6.01	0.00	98.47
	Armavir	3016.67	0.00	44520.87	67.30	0.00	47604.84	6.23	0.00	91.88	0.14	0.00	98.25
	Gegharkunik	624.30	388.85	6132.05	31265.51	48.73	38459.44	1.55	0.96	15.19	77.43	0.12	95.24
	Kotayk	302.60	54.93	13916.37	13159.93	31.53	27465.36	1.09	0.20	50.22	47.49	0.11	99.11
	Lori	215.23	266.53	3057.55	14642.45	130.48	18312.24	1.11	1.37	15.77	75.53	0.67	94.46
	Shirak	1455.57	335.67	1235.51	56858.93	0.00	59885.69	2.19	0.51	1.86	85.71	0.00	90.27
	Syunik	159.50	205.72	3845.22	32796.49	186.91	37193.84	0.41	0.53	9.89	84.36	0.48	95.68
	Tavush	0.00	367.32	611.25	7427.42	46.98	8452.96	0.00	4.33	7.21	87.56	0.55	99.65
	Vayots Dzor	57.98	9.77	2902.26	3123.01	7.33	6100.35	0.95	0.16	47.57	51.19	0.12	100.00
Armenia*	10922.2	1734.76	114731.1	193305.18	453.04	321146.21	3.26	0.52	34.20	57.63	0.14	95.74	
Diptera Esri	Aragatsotn	144.12	321.69	9358.21	6978.70	4334.75	21137.47	0.33	0.74	21.43	15.98	9.92	48.39
	Ararat	35.65	44.04	11452.05	11.34	1693.71	13236.78	0.12	0.15	38.09	0.04	5.63	44.03
	Armavir	11.09	0.00	19927.98	0.00	585.79	20524.86	0.02	0.00	32.67	0.00	0.96	33.65
	Gegharkunik	320.58	45.04	0.00	4363.80	14030.62	18760.03	0.79	0.11	0.00	10.69	34.36	45.95
	Kotayk	138.91	0.31	8083.60	2124.19	5193.71	15540.71	0.52	0.00	30.21	7.94	19.41	58.09
	Lori	113.90	606.15	0.00	7194.12	8321.40	16235.56	0.38	2.03	0.00	24.05	27.82	54.28
	Shirak	0.00	162.48	1.13	5891.14	24174.64	30229.39	0.00	0.22	0.00	8.01	32.85	41.08
	Syunik	318.16	0.05	17.08	4863.31	11095.37	16293.97	1.37	0.00	0.07	21.00	47.90	70.35
	Tavush	3.38	0.00	0.00	665.48	4625.39	5294.26	0.04	0.00	0.00	8.54	59.34	67.92
	Vayots Dzor	38.53	0.00	1740.27	152.63	760.02	2691.46	1.20	0.00	54.22	4.76	23.68	83.85
Armenia*	1124.33	1179.75	50580.32	32244.71	74815.39	159944.49	0.33	0.35	14.88	9.48	22.01	47.04	
Diptera ESA	Aragatsotn	78.50	89.98	12678.09	16821.42	15771.14	45439.13	0.17	0.19	26.99	35.82	33.58	96.75
	Ararat	1188.64	59.88	25372.26	147.73	5463.84	32232.36	3.63	0.18	77.51	0.45	16.69	98.47
	Armavir	1205.06	0.00	44515.97	0.00	1883.81	47604.84	2.49	0.00	91.87	0.00	3.89	98.25
	Gegharkunik	42.25	79.86	0.00	7778.87	30558.47	38459.44	0.10	0.20	0.00	19.26	75.68	95.24
	Kotayk	175.41	10.80	10838.18	3738.25	12702.73	27465.36	0.63	0.04	39.11	13.49	45.84	99.11
	Lori	117.50	151.54	0.00	7023.46	11019.74	18312.24	0.61	0.78	0.00	36.23	56.84	94.46
	Shirak	0.00	0.29	232.57	4852.92	54799.91	59885.69	0.00	0.00	0.35	7.32	82.61	90.27
	Syunik	167.77	0.01	11.81	8687.07	28327.19	37193.84	0.43	0.00	0.03	22.35	72.87	95.68

	Tavush	36.47	0.00	0.00	986.34	7430.15	8452.96	0.43	0.00	0.00	11.63	87.60	99.65
	Vayots Dzor	54.77	0.00	1978.92	362.80	3703.87	6100.35	0.90	0.00	32.44	5.95	60.71	100.00
	Armenia*	3066.36	392.35	95627.79	50398.85	171660.85	321146.21	0.91	0.12	28.51	15.03	51.18	95.74
Coleoptera Esri	Aragatsotn	225.97	0.00	8374.69	6747.05	0.00	15347.71	0.52	0.00	19.17	15.45	0.00	35.14
	Ararat	1089.71	0.00	101.40	7863.68	32.05	9086.84	3.62	0.00	0.34	26.16	0.11	30.22
	Armavir	348.74	0.00	5.30	13301.86	0.00	13655.89	0.57	0.00	0.01	21.81	0.00	22.39
	Gegharkunik	2223.18	0.00	10986.48	774.20	0.00	13983.86	5.44	0.00	26.91	1.90	0.00	34.25
	Kotayk	290.16	0.00	5333.75	5937.69	0.00	11561.60	1.08	0.00	19.94	22.19	0.00	43.21
	Lori	1129.59	0.00	10187.30	437.53	0.00	11754.42	3.78	0.00	34.06	1.46	0.00	39.30
	Shirak	2100.66	0.00	19566.27	1.13	0.00	21668.06	2.85	0.00	26.59	0.00	0.00	29.44
	Syunik	178.28	0.00	12028.54	205.54	0.99	12413.35	0.77	0.00	51.93	0.89	0.00	53.59
	Tavush	0.00	0.00	527.95	3604.52	0.00	4132.47	0.00	0.00	6.77	46.24	0.00	53.01
	Vayots Dzor	93.97	0.00	678.79	1348.61	15.30	2136.68	2.93	0.00	21.15	42.02	0.48	66.57
	Armenia*	7680.26	0.00	67790.48	40221.81	48.34	115740.88	2.26	0.00	19.94	11.83	0.01	34.04
	Coleoptera Esa	Aragatsotn	275.50	0.00	30473.98	12344.96	0.00	43094.44	0.59	0.00	64.89	26.29	0.00
Ararat		3558.49	0.00	3085.22	24278.78	60.45	30982.94	10.87	0.00	9.43	74.17	0.18	94.65
Armavir		1698.84	0.00	1143.06	41493.65	0.00	44335.54	3.51	0.00	2.36	85.63	0.00	91.50
Gegharkunik		2828.18	0.00	30288.38	2492.06	0.10	35608.71	7.00	0.00	75.01	6.17	0.00	88.18
Kotayk		174.45	0.00	15677.11	10445.26	0.00	26296.83	0.63	0.00	56.57	37.69	0.00	94.89
Lori		1466.61	0.00	14522.13	749.75	0.00	16738.50	7.57	0.00	74.91	3.87	0.00	86.34
Shirak		2348.26	0.00	50569.03	231.94	0.00	53149.24	3.54	0.00	76.23	0.35	0.00	80.12
Syunik		448.71	0.02	32963.27	536.56	1.45	33950.02	1.15	0.00	84.79	1.38	0.00	87.33
Tavush		2.64	0.00	1008.48	7373.50	0.00	8384.62	0.03	0.00	11.89	86.93	0.00	98.85
Vayots Dzor		541.86	0.60	3461.02	1996.01	90.05	6089.54	8.88	0.01	56.73	32.72	1.48	99.82
Armenia*		13343.5	0.62	183191.7	101942.47	152.05	298630.36	3.98	0.00	54.61	30.39	0.05	89.03

Appendix 3.2.B1. Edible and culinary plant species

Family	Species	Forest	Steppe	Semidesert	Alpine	Broadleaf woodland	Desert	Juniper	Marsh	Meadow-steppe	Subalpine meadow
Vegetable plants with edible leaves, shoots, roots, bulbs, etc.											
Alliaceae	Allium atroviolaceum		1	1		1					
Alliaceae	Allium flavum		1	1		1					
Alliaceae	Allium fuscoviolaceum		1					1			
Alliaceae	Allium jajlae	1	1			1				1	1
Alliaceae	Allium materculae			1							
Alliaceae	Allium paradoxum	1									
Alliaceae	Allium rotundum	1	1			1				1	1
Alliaceae	Allium rubellum		1	1							
Alliaceae	Allium schoenopraum				1						1
Alliaceae	Allium victorialis	1									1
Amaranthaceae	Amaranthus graecizans		1	1							
Amaranthaceae	Amaranthus retroflexus		1	1							
Apiaceae	Angelica tatianae	1									
Apiaceae	Anthriscus cereifolium			1							
Apiaceae	Astrodaucus orientalis		1	1							
Chenopodiaceae	Atriplex tatarica	1	1	1					1		
Apiaceae	Caucalis platycarpus		1							1	
Apiaceae	Chaerophyllum aureum	1	1							1	1
Apiaceae	Chaerophyllum bulbosum	1	1							1	1
Apiaceae	Eryngium campestre		1	1							
Apiaceae	Falcaria vulgaris		1	1						1	
Apiaceae	Ferula szovitsiana			1							
Apiaceae	Heracleum schelkovnikovii									1	1
Apiaceae	Hippomarathrum microcarpum		1	1							
Apiaceae	Laser trilobum	1				1				1	1
Apiaceae	Peucedanum caucasicum	1									
Apiaceae	Pimpinella saxifraga		1							1	1
Asparagaceae	Asparagus officinalis	1	1			1		1		1	1

Asparagaceae	Asparagus verticillatus	1				1		1	1		
Asphodelaceae	Eremurus spectabilis		1			1				1	1
Asteraceae	Arctium palladinii	1	1					1	1		
Asteraceae	Cichorium intybus	1	1	1		1		1		1	1
Asteraceae	Echinops sphaerocephalus	1	1			1				1	1
Asteraceae	Gundelia hajastana		1								
Asteraceae	Podospermum armeniacum		1	1							
Asteraceae	Podospermum laciniatum		1	1							
Asteraceae	Taraxacum officinale	1	1	1	1	1		1		1	1
Asteraceae	Tragopogon coloratus		1	1							
Asteraceae	Tragopogon reticulatus				1						1
Asteraceae	Tragopogon serotinus			1			1				
Asteraceae	Tussilago farfara	1	1	1		1		1		1	1
Brassicaceae	Bunias orientalis		1			1		1		1	1
Brassicaceae	Capsella bursa-pastoris	1	1	1		1		1		1	1
Brassicaceae	Cardamine uliginosa								1		
Brassicaceae	Lepidium latifolium								1		
Brassicaceae	Nasturtium officinale								1		
Cannabaceae	Humulus lupulus	1				1					1
Capparaceae	Capparis herbacea			1							
Caryophyllaceae	Stellaria media	1							1		
Chenopodiaceae	Atriplex nitens			1							
Chenopodiaceae	Atriplex tatarica			1							
Chenopodiaceae	Chenopodium album	1	1	1		1		1		1	
Colchicaceae	Merendera trigyna	1	1	1						1	
Convallariaceae	Polygonatum glaberrimum	1									
Convallariaceae	Polygonatum orientale	1				1					
Convallariaceae	Polygonatum vericillatum	1									
Corylaceae	Corylus avellana	1									
Fabaceae	Lathyrus tuberosus	1	1			1					
Hyacinthaceae	Ornithogalum hajastanum	1	1			1		1		1	1
Hyacinthaceae	Puschkinia scilloides				1						1
Malvaceae	Malva neglecta	1	1			1				1	
Malvaceae	Malva sylvestris	1	1								
Polygonaceae	Rumex acetosa								1		
Polygonaceae	Rumex acetoselloides								1		
Polygonaceae	Rumex alpinus				1						
Polygonaceae	Rumex crispus								1	1	1
Polygonaceae	Rumex scutatus	1	1						1	1	1
Polygonaceae	Rumex tuberosus	1	1			1			1	1	1
Portulacaceae	Portulaca oleracea		1	1		1		1			
Rosaceae	Rubus caesius	1				1					1
Rosaceae	Rubus caucasicus	1				1					
Rosaceae	Rubus idaeus	1	1			1				1	1
Rosaceae	Rubus saxatilis	1				1					1
Urticaceae	Urtica dioica	1	1	1		1		1	1	1	
Urticaceae	Urtica urens	1				1					
Number of species across vegetation zones		38	41	28	5	28	1	12	13	27	27
Fruits, berries, nuts											
Berberidaceae	Berberis orientalis	1				1				1	1
Berberidaceae	Berberis vulgaris	1				1				1	1
Cornaceae	Cornus mas	1				1					
Ebenaceae	Diospyros lotus	1				1					
Elaeagnaceae	Elaeagnus angustifolia		1	1					1		
Elaeagnaceae	Hippophae rhamnoides	1							1	1	
Grossulariaceae	Grossularia reclinata	1									
Grossulariaceae	Ribes biebersteinii	1									
Moraceae	Ficus carica	1		1		1					
Punicaceae	Punica granatum		1			1					
Rosaceae	Cerasus avium	1									

Rosaceae	Crataegus kyrtostyla	1									
Rosaceae	Crataegus orientalis	1									
Rosaceae	Crataegus pentagyna	1									
Rosaceae	Fragaria vesca	1									
Rosaceae	Malus orientalis	1									
Rosaceae	Mespilus germanica	1				1					
Solanaceae	Physalis alkekengi	1				1					
Rosaceae	Prunus divaricata	1	1			1				1	
Rosaceae	Prunus spinosa	1									
Rosaceae	Pyrus caucasica	1									
Rosaceae	Rosa spp.	1	1			1		1		1	
Rosaceae	Rubus caesius	1				1				1	
Rosaceae	Rubus candicans	1									
Rosaceae	Rubus caucasicus	1									
Rosaceae	Rubus idaeus	1	1			1				1	
Rosaceae	Rubus saxatilis	1				1				1	
Number of species across vegetation zones		25	5	2		13		1	2	5	7
Spicy plants											
Apiaceae	Chamaescidium acaule					1					
Araceae	Arum orientale	1									
Lamiaceae	Melissa officinalis	1									
Lamiaceae	Mentha longifolia		1			1		1	1	1	
Lamiaceae	Origanum vulgare	1	1							1	1
Lamiaceae	Salvia sclarea		1	1							
Lamiaceae	Satureja hortensis					1		1			
Lamiaceae	Thymus kotschyanus		1	1		1		1		1	1
Lamiaceae	Ziziphora tenuior		1	1		1		1			
Number of species across vegetation zones		3	5	3	1	4		4	1	3	2
Plants used for alcohol drinks											
Cornaceae	Cornus mas	1				1					
Rosaceae	Malus orientalis	1									
Rosaceae	Prunus divaricata	1	1			1					1
Rosaceae	Prunus spinosa	1									
Rosaceae	Pyrus caucasica	1									
Number of species across vegetation zones		5	1			2					1
Plants used for non-alcohol drinks											
Berberidaceae	Berberis orientalis	1				1				1	1
Berberidaceae	Berberis vulgaris	1				1				1	1
Cornaceae	Cornus mas	1				1					
Elaeagnaceae	Hippophae rhamnoides	1							1	1	
Fabaceae	Glycyrrhiza glabra		1	1					1		
Grossulariaceae	Ribes biebersteinii	1									
Hypericaceae	Hypericum perforatum	1	1			1				1	1
Lamiaceae	Mentha longifolia		1			1		1	1	1	
Lamiaceae	Thymus kotschyanus		1	1		1		1		1	1
Onagraceae	Chamaenerion angustifolia		1			1				1	1
Punicaceae	Punica granatum		1			1					
Rosaceae	Prunus divaricata	1	1			1					1
Rosaceae	Prunus spinosa	1									
Rosaceae	Pyrus caucasica	1									
Rosaceae	Sorbus aucuparia	1									1
Rosaceae	Rubus idaeus	1	1			1				1	1
Tiliaceae	Tilia caucasica	1									
Number of species across vegetation zones		12	8	2		10		2	3	8	8

Appendix 3.2.B2. Medicinal plant species

Family	Species	Forest	Steppe	Semidesert	Alpine	Broadleaf woodland	Desert	Juniper	Marsh	Meadow-steppe	Subalpine meadow
Alliaceae	<i>Allium paradoxum</i>	1									
Apiaceae	<i>Carum caucasicum</i>				1						
Apiaceae	<i>Conium maculatum</i>	1	1							1	1
Apiaceae	<i>Sanicula europaea</i>	1									
Araceae	<i>Acorus calamus</i>								1		
Araceae	<i>Arum orientale</i>	1									
Araliaceae	<i>Hedera helix</i>	1									
Asclepiadaceae	<i>Periploca graeca</i>	1							1		
Asparagaceae	<i>Asparagus officinalis</i>	1	1			1				1	1
Aspidiaceae	<i>Dryopteris filix-mas</i>	1									
Aspleniaceae	<i>Phyllitis scolopendrium</i>	1									
Asteraceae	<i>Achillea millefolium</i>		1	1		1	1	1			
Asteraceae	<i>Achillea nobilis</i>		1	1						1	1
Asteraceae	<i>Arctium palladinii</i>	1	1	1		1		1	1	1	
Asteraceae	<i>Artemisia abrotanum</i>		1								
Asteraceae	<i>Artemisia absinthium</i>	1	1	1	1	1	1	1		1	1
Asteraceae	<i>Artemisia vulgaris</i>	1							1		
Asteraceae	<i>Bidens tripartita</i>								1		
Asteraceae	<i>Calendula persica</i>			1							
Asteraceae	<i>Cichorium intybus</i>	1	1	1		1		1		1	1
Asteraceae	<i>Cnicus benedictus</i>		1	1		1		1			
Asteraceae	<i>Eupatorium cannabinum</i>								1		
Asteraceae	<i>Gnaphalium uliginosum</i>								1		
Asteraceae	<i>Grindelia squarrosa</i>		1	1			1				
Asteraceae	<i>Helichrysum plicatum</i>		1			1		1		1	1
Asteraceae	<i>Inula helenium</i>	1							1		
Asteraceae	<i>Lactuca georgica</i>		1			1					
Asteraceae	<i>Lactuca serriola</i>		1	1		1	1	1		1	
Asteraceae	<i>Onopordum acanthium</i>		1	1		1		1		1	
Asteraceae	<i>Petasites hybridus</i>	1							1		
Asteraceae	<i>Senecio jacobaea</i>		1								
Asteraceae	<i>Silybum marianum</i>	1	1			1					
Asteraceae	<i>Tanacetum vulgare</i>		1							1	1
Asteraceae	<i>Taraxacum officinalis</i>	1	1	1	1	1		1		1	1
Asteraceae	<i>Tussilago farfara</i>	1	1	1	1	1		1		1	1
Asteraceae	<i>Xeranthemum squarrosum</i>		1	1		1		1			
Berberidaceae	<i>Berberis vulgaris</i>	1				1				1	1
Betulaceae	<i>Betula litwinowii</i>										1
Boraginaceae	<i>Anchusa italica</i>	1	1	1		1		1			
Boraginaceae	<i>Cynoglossum officinale</i>		1	1							
Boraginaceae	<i>Lithospermum officinale</i>	1									
Boraginaceae	<i>Symphytum caucasicum</i>								1		
Brassicaceae	<i>Capsella bursa-pastoris</i>	1	1	1	1	1	1	1		1	1
Brassicaceae	<i>Erophila verna</i>		1	1		1		1			
Brassicaceae	<i>Nasturtium officinale</i>								1		
Brassicaceae	<i>Sisymbrium officinale</i>		1			1		1			
Cannabaceae	<i>Humulus lupulus</i>	1									
Caprifoliaceae	<i>Sambucus nigra</i>	1	1						1		
Caprifoliaceae	<i>Viburnum lantana</i>	1								1	1
Caryophyllaceae	<i>Cocciganthe flos-cuculi</i>								1		
Caryophyllaceae	<i>Herniaria glabra</i>		1	1		1		1		1	
Caryophyllaceae	<i>Stellaria media</i>	1							1		
Chenopodiaceae	<i>Halostachys belangeriana</i>								1		
Convolvulaceae	<i>Calystegia sepium</i>	1		1					1		

Cucurbitaceae	Bryonia alba	1	1			1		1		1	
Cupressaceae	Juniperus communis							1			
Cupressaceae	Juniperus sabina										1
Elaeagnaceae	Elaeagnus angustifolia		1	1					1		
Elaeagnaceae	Hippophae rhamnoides	1							1	1	
Ephedraceae	Ephedra procera		1	1		1		1			
Equisetaceae	Equisetum arvense	1							1		
Ericaceae	Vaccinium myrtillus										1
Fabaceae	Galega officinalis	1									
Fabaceae	Genista tinctoria		1	1		1					
Fabaceae	Glycyrrhiza glabra		1	1		1			1		
Fabaceae	Lathyrus sativus	1									1
Fabaceae	Melilotus officinalis		1	1		1	1	1	1	1	1
Fabaceae	Ononis arvensis		1						1	1	1
Fabaceae	Sphaerophysa salsula			1					1		
Fagaceae	Quercus iberica	1									
Fagaceae	Quercus macranthera	1									
Fumariaceae	Fumaria officinalis		1	1		1		1			
Gentianaceae	Gentiana septemfida		1							1	1
Geraniaceae	Geranium dissectum	1	1							1	
Geraniaceae	Geranium robertianum	1									
Hyacinthaceae	Scilla armena					1					1
Hyacinthaceae	Scilla siberica	1	1			1				1	1
Hypericaceae	Hypericum perforatum	1	1							1	1
Iridaceae	Crocus speciosus	1	1			1				1	
Juglandaceae	Juglans regia	1									
Lamiaceae	Betonica officinalis	1	1								
Lamiaceae	Glechoma hederacea	1									
Lamiaceae	Hyssopus angustifolius		1							1	1
Lamiaceae	Lamium album	1	1	1	1	1	1	1	1	1	1
Lamiaceae	Leonurus cardiaca								1		
Lamiaceae	Melissa officinalis	1									
Lamiaceae	Mentha longifolia								1		
Lamiaceae	Origanum vulgare	1	1							1	1
Lamiaceae	Salvia dracocephaloides		1	1		1		1			
Lamiaceae	Salvia nemorosa		1							1	1
Lamiaceae	Salvia sclarea		1	1		1		1			
Lamiaceae	Teucrium polium		1	1							
Lamiaceae	Thymus kotschyanus		1	1		1		1		1	1
Liliaceae	Lilium armenum					1				1	1
Liliaceae	Polygonatum odoratum	1									
Loranthaceae	Viscum album	1				1					
Malvaceae	Althaea officinalis								1		
Malvaceae	Malva sylvestris	1	1								
Melanthiaceae	Veratrum album									1	1
Menyanthaceae	Menyanthes trifoliata								1		
Nymphaeaceae	Nuphar lutea								1		
Nymphaeaceae	Nymphaea alba								1		
Orchidaceae	Neottia nidus-avis	1									
Oxalidaceae	Oxalis corniculata	1									
Paeoniaceae	Paeonia tenuifolia	1				1					
Papaveraceae	Chelidonium majus	1	1						1	1	
Papaveraceae	Papaver orientale		1			1				1	1
Peganaceae	Peganum harmala		1	1		1		1			
Plantaginaceae	Plantago lanceolata	1	1	1		1	1	1	1	1	1
Poaceae	Elytrigia repens		1	1		1		1		1	
Polygalaceae	Polygala anatolica	1	1			1				1	1
Polygonaceae	Polygonum hydropiper								1		
Polygonaceae	Rumex crispus								1	1	
Primulaceae	Anagallis arvensis	1	1							1	

Primulaceae	Cyclamen vernum	1									
Primulaceae	Lysimachia verticillaris	1						1			
Primulaceae	Primula macrocalyx	1	1			1		1		1	1
Punicaceae	Punica granatum		1			1					
Ranunculaceae	Aconitum orientale									1	1
Ranunculaceae	Adonis aestivalis		1	1		1		1		1	1
Ranunculaceae	Pulsatilla albana		1							1	1
Rhamnaceae	Rhamnus cathartica	1									
Rosaceae	Agrimonia eupatoria		1			1				1	1
Rosaceae	Filipendula ulmaria		1							1	1
Rosaceae	Fragaria vesca	1								1	1
Rosaceae	Geum urbanum	1							1		
Rosaceae	Potentilla anserina	1	1			1				1	1
Rosaceae	Potentilla erecta								1		
Rosaceae	Prunus spinosa	1									
Rosaceae	Rubus idaeus	1	1			1				1	1
Rosaceae	Rosa spp.	1	1	1		1		1	1	1	1
Rosaceae	Sanguisorba officinalis		1							1	1
Rosaceae	Sorbus aucuparia	1									1
Rubiaceae	Asperula glomerata	1	1			1		1		1	1
Rubiaceae	Rubia tinctorum		1			1		1			
Salicaceae	Populus tremula	1									
Salicaceae	Salix alba	1							1		
Scrophulariaceae	Digitalis ferruginea	1									
Scrophulariaceae	Digitalis nervosa	1									
Scrophulariaceae	Verbascum georgicum		1							1	1
Scrophulariaceae	Verbascum thapsus	1							1		
Scrophulariaceae	Veronica beccabunga								1		
Smilacaceae	Smilax excelsa	1									
Solanaceae	Atropa bella-donna	1									
Solanaceae	Datura stramonium	1	1			1		1	1	1	1
Solanaceae	Hyoscyamus niger		1	1		1		1	1	1	1
Solanaceae	Physalis alkekengi	1				1					
Solanaceae	Solanum dulcamara	1	1						1	1	1
Thymelaeaceae	Daphne mezereum	1									
Tiliaceae	Tilia cordata	1									
Urticaceae	Parietaria officinalis	1								1	1
Urticaceae	Urtica dioica	1	1	1	1	1	1	1	1	1	1
Urticaceae	Urtica urens	1									1
Valerianaceae	Valeriana officinalis	1	1							1	1
Verbenaceae	Verbena officinalis	1	1	1		1		1			
Number of species across vegetation zones		83	76	39	8	54	9	37	45	58	53

Appendix 3.2.B3. Honey plant species

Family	Species	Forest	Steppe	Semidesert	Alpine	Broadleaf woodland	Desert	Juniper	Marsh	Meadow-steppe	Subalpine meadow
Aceraceae	Acer assyriacum	1									
Aceraceae	Acer campestre	1									
Aceraceae	Acer hyrcanum	1									
Aceraceae	Acer ibericum	1									
Aceraceae	Acer platanoides	1									
Aceraceae	Acer trautvetteri	1									
Alliaceae	Allium albidum		1								
Alliaceae	Allium atroviolaceum										
Alliaceae	Allium aucheri	1			1						1
Alliaceae	Allium cardiostemon		1							1	

Alliaceae	Allium	flavum		1	1							
Alliaceae	Allium	fuscoviolaceum		1				1				
Alliaceae	Allium	jajlae	1	1								1
Alliaceae	Allium	karsianum		1							1	1
Alliaceae	Allium	kunthianum		1							1	1
Alliaceae	Allium	materculae			1		1	1				
Alliaceae	Allium	paradoxum	1									
Alliaceae	Allium	pseudostrictum				1					1	1
Alliaceae	Allium	rotundum		1			1		1		1	1
Alliaceae	Allium	schoenoprasum				1						1
Alliaceae	Allium	vineale								1	1	1
Apiaceae	Astrantia	maxima	1								1	1
Apiaceae	Pimpinella	anthriscoides	1									
Apiaceae	Pimpinella	confusa		1			1		1		1	1
Apiaceae	Pimpinella	peucedanifolia	1									
Apiaceae	Pimpinella	rhodantha		1							1	1
Apiaceae	Pimpinella	saxifraga		1								
Apiaceae	Pimpinella	tripartita	1				1					
Araliaceae	Hedera	helix	1									
Asclepiadaceae	Cynanchum	acutum		1	1		1			1		
Asclepiadaceae	Vincetoxicum	amplifolium	1	1	1						1	
Asteraceae	Arctium	palladinii	1	1						1		
Asteraceae	Aster	ibericus		1			1				1	1
Asteraceae	Centaurea	behen		1							1	
Asteraceae	Centaurea	carduiformis		1	1						1	1
Asteraceae	Centaurea	cheiranthifolia				1						1
Asteraceae	Centaurea	depressa		1	1							
Asteraceae	Centaurea	iberica		1	1		1		1			
Asteraceae	Centaurea	pseudoscabiosa		1	1		1		1		1	
Asteraceae	Centaurea	ruthenica		1								
Asteraceae	Centaurea	solstitialis		1	1		1		1			
Asteraceae	Centaurea	triumfettii		1		1					1	1
Asteraceae	Cirsium	anatolicum	1	1								
Asteraceae	Cirsium	ciliatum		1								
Asteraceae	Cirsium	cosmelii	1	1		1	1		1		1	1
Asteraceae	Cirsium	echinus		1							1	1
Asteraceae	Cirsium	esculentum	1									1
Asteraceae	Cirsium	incanum		1	1						1	1
Asteraceae	Cichorium	intybus	1	1	1		1		1		1	1
Asteraceae	Echinops	plyacanthus		1								
Asteraceae	Echinops	sphaerocephalus	1	1			1		1		1	1
Asteraceae	Leontodon	hispidus										1
Asteraceae	Psephellus	pambakensis	1									
Asteraceae	Onopordum	acanthium		1	1		1		1		1	1
Asteraceae	Silybum	maruanum	1	1								
Asteraceae	Solidago	virgaurea	1									1
Asteraceae	Sonchus	arvensis		1			1		1			
Asteraceae	Sonchus	asper								1		1
Asteraceae	Taraxacum	officinale	1	1	1	1	1		1		1	1
Asteraceae	Taraxacum	stevenii				1						
Berberidaceae	Berberis	iberica	1				1		1			
Berberidaceae	Berberis	vulgaris	1				1		1			
Betulaceae	Betula	litwinowii	1									
Boraginaceae	Echium	italicum		1	1		1		1			
Boraginaceae	Echium	maculatum		1							1	1
Boraginaceae	Echium	vulgare		1							1	1
Boraginaceae	Symphytum	asperum	1	1						1	1	1
Brassicaceae	Barbarea	plantaginea								1	1	
Brassicaceae	Barbarea	vulgaris								1	1	
Brassicaceae	Berteroa	incana		1			1		1			

Campanulaceae	Campanula	bononiensis	1	1						1	1
Campanulaceae	Campanula	glomerata		1						1	1
Campanulaceae	Campanula	rapunculoides	1	1			1		1		
Campanulaceae	Campanula	stevenii		1			1		1		1
Campanulaceae	Campanula	tridentata					1				1
Cannabaceae	Humulus	lupulus	1								
Capparaceae	Capparis	herbacea					1				
Caprifoliaceae	Lonicera	caucasica	1				1		1		
Caprifoliaceae	Lonicera	iberica	1				1		1		
Caprifoliaceae	Viburnum	lantana	1				1		1		1
Caryophyllaceae	Gypsophila	aretioides		1							
Caryophyllaceae	Gypsophila	bicolor		1	1		1		1		
Caryophyllaceae	Gypsophila	elegans		1	1		1		1		
Caryophyllaceae	Silene	alba	1	1	1		1		1		1
Caryophyllaceae	Silene	chlorifolia	1	1							1
Caryophyllaceae	Silene	compacta	1								1
Caryophyllaceae	Silene	italica		1	1		1		1		
Caryophyllaceae	Silene	spergulifolia	1	1	1		1		1		1
Cistaceae	Helianthemum	grandiflorum	1	1	1		1		1		1
Cistaceae	Helianthemum	nummularium		1	1		1		1		
Cistaceae	Helianthemum	salicifolium		1	1						
Colchicaceae	Merendera	raddeana					1				1
Colchicaceae	Merendera	trigyna	1	1			1				1
Convolvulaceae	Convolvulus	arvensis	1	1	1		1		1		1
Cornaceae	Cornus	mas	1				1				
Cornaceae	Swida	australis					1				
Corylaceae	Carpinus	betulus	1								
Corylaceae	Carpinus	orientalis	1				1				
Corylaceae	Corylus	avellana	1								
Dipsacaceae	Scabiosa	argentea		1	1		1		1		
Dipsacaceae	Scabiosa	bipinnata		1							1
Dipsacaceae	Scabiosa	caucasica									1
Dipsacaceae	Scabiosa	rotata		1	1		1		1		
Elaeagnaceae	Elaeagnus	angustifolia	1				1				1
Elaeagnaceae	Hippophae	ramnoides	1				1				1
Ericaceae	Rhododendron	caucasicum	1								1
Ericaceae	Vaccinium	myrtillus	1								1
Fabaceae	Alhagi	pseudoalhagi			1						
Fabaceae	Astragalus	paradoxus							1		
Fabaceae	Astragalus	microcephalus		1							1
Fabaceae	Caragana	grandiflora					1				
Fabaceae	Genista	transcaucasica	1	1			1				
Fabaceae	Coronilla	varia		1							1
Fabaceae	Glycyrrhiza	glabra		1	1					1	
Fabaceae	Lathyrus	cyaneus	1	1							1
Fabaceae	Lathyrus	miniatus	1	1			1				1
Fabaceae	Lathyrus	pratensis		1			1				1
Fabaceae	Lathyrus	tuberosus	1				1				
Fabaceae	Lotus	caucasicus		1						1	1
Fabaceae	Medicago	sativa		1	1		1		1		1
Fabaceae	Onobrychis	altissima		1							1
Fabaceae	Onobrychis	buhseana		1	1						
Fabaceae	Onobrychis	cornuta		1							
Fabaceae	Onobrychis	radiata		1	1		1		1		1
Fabaceae	Onobrychis	transcausicus		1	1		1		1		1
Fabaceae	Robinia	pseudoacacia	1	1	1						
Fabaceae	Sophora	alopecuroides		1	1					1	
Fabaceae	Trifolium	ambiguum		1							1
Fabaceae	Trifolium	arvense		1	1		1				1
Fabaceae	Trifolium	brodzilowskyi		1							1

Fabaceae	Trifolium	canescens	1	1						1	1
Fabaceae	Trifolium	diffusum		1						1	1
Fabaceae	Trifolium	hybridum		1		1				1	1
Fabaceae	Trifolium	medium	1	1		1		1		1	1
Fabaceae	Trifolium	pratense	1	1		1		1		1	1
Fabaceae	Trifolium	repens	1	1					1	1	1
Fabaceae	Trifolium	spadiceum							1		1
Fabaceae	Trifolium	trichocephalum	1	1						1	1
Fabaceae	Vicia	alpestris								1	1
Fabaceae	Vicia	balansae		1						1	1
Fabaceae	Vicia	cracca	1	1	1		1		1	1	1
Fabaceae	Vicia	sepium		1	1		1		1	1	1
Fabaceae	Vicia	variegata	1	1	1		1		1	1	1
Fagaceae	Fagus	orientalis	1								
Fagaceae	Quercus	iberica	1								
Fagaceae	Quercus	macranthera	1								
Geraniaceae	Erodium	armenum				1					
Geraniaceae	Erodium	oxyrrhynchum		1	1		1		1		
Geraniaceae	Geranium	collinum	1	1	1		1		1	1	1
Geraniaceae	Geranium	ibericum		1						1	1
Geraniaceae	Geranium	pyrenaicum	1	1						1	1
Geraniaceae	Geranium	sanguineum	1	1						1	1
Geraniaceae	Geranium	sylvaticum	1	1			1		1	1	1
Geraniaceae	Geranium	tuberosum		1	1		1		1	1	
Grossulariaceae	Grossularia	reclinata	1								
Grossulariaceae	Ribes	biebersteinii	1				1			1	1
Hypericaceae	Hypericum	perforatum	1	1			1			1	1
Iridaceae	Gladiolus	caucasicus								1	1
Iridaceae	Gladiolus	kotschyanus		1						1	1
Iridaceae	Gladiolus	tenuis								1	1
Iridaceae	Iris	caucasica		1			1		1	1	1
Iridaceae	Iris	furcata		1						1	1
Iridaceae	Iris	imbricata	1	1						1	1
Iridaceae	Iris	pumila		1	1						
Lamiaceae	Lallemantia	iberica		1	1		1		1		
Lamiaceae	Lallemantia	peltata		1	1		1		1		
Lamiaceae	Lamium	album	1	1	1		1		1	1	1
Lamiaceae	Leonurus	cardiaca	1	1					1	1	1
Lamiaceae	Marrubium	vulgare		1	1						
Lamiaceae	Melissa	officinalis	1								
Lamiaceae	Mentha	longifolia	1	1	1				1		
Lamiaceae	Origanum	vulgare	1	1			1			1	1
Lamiaceae	Salvia	nemorosa		1			1		1	1	1
Lamiaceae	Salvia	verticillata	1	1			1		1	1	
Lamiaceae	Satureja	hortensis		1	1		1				
Lamiaceae	Scutellaria	orientalis		1	1		1		1	1	1
Lamiaceae	Stachys	atherocalyx	1	1	1		1		1	1	
Lamiaceae	Stachys	sylvatica	1	1							
Lamiaceae	Thymus	kotschyanus		1	1		1		1		
Lamiaceae	Thymus	rariflorus	1	1	1		1		1		
Lythraceae	Lythrum	salicaria							1		
Malvaceae	Alcea	rugosa		1	1		1		1		
Malvaceae	Althaea	officinalis							1		
Oleaceae	Ligustrum	vulgare	1								
Onagraceae	Chamaenerion	angustifolium		1						1	1
Onagraceae	Epilobium	hirsutum							1		
Papaveraceae	Papaver	macrostomum		1	1		1		1	1	
Papaveraceae	Papaver	orientale		1	1		1		1	1	1
Papaveraceae	Papaver	paucifoliatum		1	1		1		1	1	1
Plantaginaceae	Plantago	major	1	1			1		1	1	1

Plantaginaceae	Plantago	lanceolata	1	1			1		1		1	1
Plumbaginaceae	Acantholimon	armenum		1			1		1			
Plumbaginaceae	Acantholimon	glumaceum		1			1		1		1	
Polemoniaceae	Polemonium	caeruleum							1			
Polygalaceae	Polygala	anatolica	1	1			1		1		1	1
Ranunculaceae	Ranunculus	aragazi				1						
Ranunculaceae	Ranunculus	caucasicus	1								1	1
Ranunculaceae	Ranunculus	repens							1			
Rhamnaceae	Paliurus	spina-christi					1					
Rosaceae	Cerasus	avium	1									
Rosaceae	Crataegus	curvisepala	1				1					
Rosaceae	Crataegus	orientalis	1				1					
Rosaceae	Filipendula	ulmaria							1		1	1
Rosaceae	Filipendula	vulgare									1	1
Rosaceae	Malus	orientalis	1									
Rosaceae	Mespilus	germanica	1				1					
Rosaceae	Potentilla	recta	1	1	1		1		1		1	1
Rosaceae	Prunus	divaricata	1	1			1					
Rosaceae	Prunus	spinosa	1				1					
Rosaceae	Pyrus	caucasica	1				1					
Rosaceae	Pyrus	salicifolia	1	1			1					
Rosaceae	Pyrus	syriaca		1			1					
Rosaceae	Rosa	canina		1			1		1		1	
Rosaceae	Rosa	iberica		1			1		1		1	
Rosaceae	Rosa	pulverulenta	1	1			1		1		1	
Rosaceae	Rosa	spinosissima		1			1		1		1	1
Rosaceae	Rubus	anatolicus	1				1					
Rosaceae	Rubus	caesius	1				1				1	
Rosaceae	Rubus	idaeus	1	1			1				1	1
Rosaceae	Sorbus	aucuparia	1									1
Rosaceae	Spiraea	crenata		1			1					
Rosaceae	Spiraea	hypericifolia		1			1					
Rutaceae	Dictamnus	albus	1				1					
Salicaceae	Salix	caprea	1						1			1
Salicaceae	Salix	excelsa	1						1			
Salicaceae	Salix	pentatroides	1						1			
Salicaceae	Salix	triandra	1						1			
Scrophulariaceae	Linaria	genistifolia		1			1					
Scrophulariaceae	Melampyrum	arvense	1								1	1
Scrophulariaceae	Rhinanthus	mediterraneus		1							1	1
Scrophulariaceae	Scrophularia	chrysantha		1			1		1		1	1
Scrophulariaceae	Scrophularia	variegata			1							
Scrophulariaceae	Verbascum	georgicum		1							1	1
Scrophulariaceae	Verbascum	laxum		1	1		1		1		1	1
Thymelaeaceae	Daphne	glomerata	1	1			1		1		1	1
Tiliaceae	Tilia	cordata	1									
Ulmaceae	Ulmus	carpinifolia	1				1					
Ulmaceae	Ulmus	glabra	1				1					
Number of species across vegetation zones			112	144	59	12	108	2	70	26	108	105